



RamJet® Self-Contained Compactor Container
RJ-88SC, RJ-100SC, RJ-250WD, RJ-250SC, RJ-250SC ULTRA, RJ-SC²
Includes HT (Hydraulic Tailgate) and SL (Streamline®, Liquid Removal) Units
OPERATION, SERVICE, AND INSTALLATION

ISSUED DECEMBER 2025

CUSTOMER NAME: _____

SERIAL NUMBER: _____

COMPACTION & RECYCLING SOLUTIONS

0018-RJSC-1225

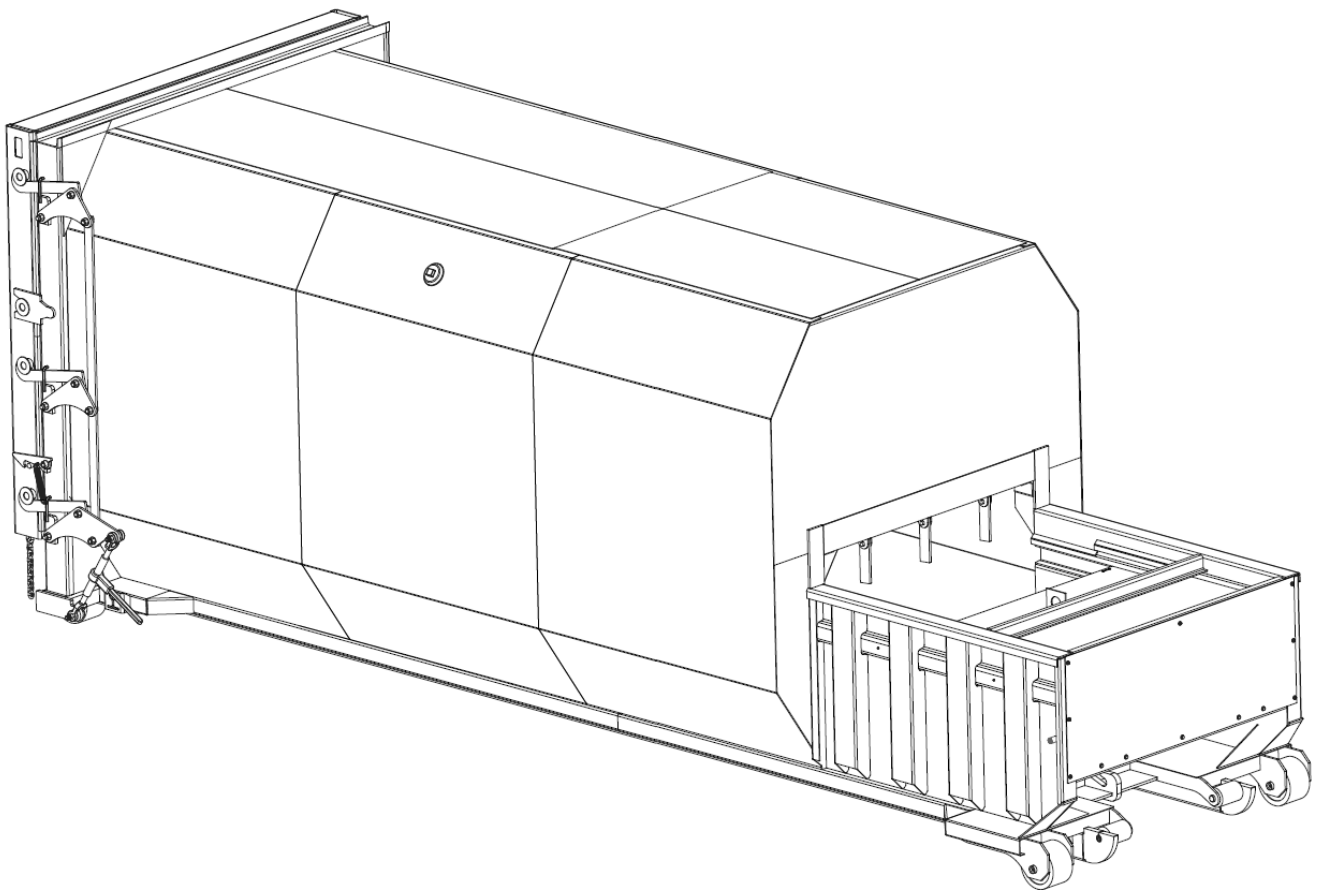

© 2025 Marathon Equipment Company



Environmental Solutions Group
201 W. Main Street, Ste 300
Chattanooga, TN 37408

Marathon Customer Care: 1.800.633.8974



WARNING

IF INCORRECTLY USED, THIS EQUIPMENT CAN CAUSE SEVERE INJURY. THOSE WHO USE AND MAINTAIN THE EQUIPMENT SHOULD BE TRAINED IN ITS PROPER USE, WARNED OF ITS DANGERS, AND SHOULD READ AND FULLY UNDERSTAND THIS ENTIRE MANUAL BEFORE ATTEMPTING TO SET UP, OPERATE, ADJUST OR SERVICE THE EQUIPMENT. KEEP THIS MANUAL FOR FUTURE REFERENCE

IMPORTANT SAFETY NOTICE

Proper service and repair are important to the safe, reliable operation of the Marathon Equipment Company products. Service procedures recommended by Marathon Equipment Company are described in this Operation, Service, and Installation Manual and are effective for performing service operations. Some of these service operations may require the use of tools or blocking devices specially designed for the purpose. Special tools should be used when and as recommended. It is important to note that some warnings against the use of specific methods that can damage the product or render it unsafe are stated in the service manual. It is also important to understand these warnings are not exhaustive. Marathon Equipment Company could not possibly know, evaluate and advise the service trade of all conceivable ways in which service might be done or of the possible hazardous consequences of each method. Consequently, Marathon Equipment Company has not undertaken any such broad evaluations. Accordingly, anyone who uses service procedures or tools which are not recommended by Marathon Equipment Company must first satisfy himself thoroughly that neither his safety nor the product safety will be jeopardized by the method he selects.

RamJet Self-Contained Compactor Container

TABLE OF CONTENTS

General Information

Introduction	4
Preface	5
Hazard Symbols and Definitions	6
Lock-Out/Tag-Out Instructions	7
Specifications	9
Service/Parts Assistance	11
Grease Lubrication Recommendation	11
Recommended Oils	11
Guards and Access Covers	12
Warning Decals on the Unit	12
Decal Care	13
Hydraulic Symbols	15
Electrical Symbols	17

Installation

Contact Information	20
Concrete Pad Requirements	21
Steel Installation Procedures	22
Electric and Hydraulic Installation	23
Through-the-Wall Power Unit Installation	25

Operation

Contact Information	28
Compactor Pre-Operation Instructions	29
Standard Control Panel	30
Operating Instructions - Standard Models	31
Control Panel With Integral Dumper	32
Operating Instructions - Standard Models with Integral Dumper	33
Control Panel - Models with Photoelectric Cycle Control	34
Operating Instructions - Models with Photoelectric Cycle Control	36
Optional Controls	37

Hauler Information

Hauler Instructions - General	40
Securing Tailgate into Chain Keeper	41
Tailgate/Latch Operation	43
Hydraulic Tailgate Operation for Optional HT Units	45
Liquid Removal for Optional SL Units	48
Integral Dumper Operation	49

Service

Contact Information	52
Compactor Lock-Out/Tag-Out Instructions	53
Periodic Maintenance	55
Maintenance Schedule Form	57
Pressure Settings	58
Pressure Gauge Readings for Compactors	60
Principles of Operation	62

RamJet Self-Contained Compactor Container

TABLE OF CONTENTS

Fuse, Circuit Breaker, & Wire Size Charts63

Tailgate Seal Replacement66

PLC Maintenance - Layout & Description67

Electrical Schematic69

Hydraulic Schematic - Typical (Cycon)70

Hydraulic Schematic with Integral Dumper71

Troubleshooting Chart72

Replacement Parts

Contact Information76

Cylinders / Miscellaneous Hardware77

100SC, 250SC Ram Assembly Parts78

Understructure and Latch79

Tailgate Assembly Parts80

Top Cover Parts81

Hopper Assembly Parts82

Hopper Interlock Parts83

Miscellaneous Hardware 250 SC HT84

Power Unit - Standard 5 HP86

Power Unit - Standard 5 HP Parts Lists87

Power Unit - 10 HP88

Power Unit - 10 HP Parts List89

Power Unit with Integral Dumper - 10 HP90

Power Unit with Integral Dumper - 10 HP - Parts List91

Typical Panel Box Configuration93

Electrical Parts List94

Decal Placement95

Decal List108

Decal Images110

Decals for Hydraulic Tailgate (HT) Units115

Decals for Integral Dumper116

Index..... 117

RamJet[®] Self-Contained Compactor Container

RJ-88SC, RJ-100SC, RJ-250WD, RJ-250SC, RJ-250SC ULTRA, RJ-SC²

INCLUDES HT (HYDRAULIC TAILGATE) UNITS AND SL (STREAMLINE[®], LIQUID REMOVAL) UNITS

OPERATION, SERVICE, AND INSTALLATION

ISSUED DECEMBER 2025

0018-RJSC-1225

INTENTIONALLY LEFT BLANK

SECTION 1

GENERAL INFORMATION

RamJet Self-Contained Compactor Container

General Information

INTRODUCTION

Thank you for purchasing a Marathon® RamJet Self-Contained Compactor Container!

This product is designed to give you reliable service and superior performance for years to come. The purpose of this manual is to provide the owner and/or operators with the necessary information to properly install, operate, and maintain the machine. Also included are sections regarding troubleshooting and service procedures. The manual is not intended as a primary training source, but as a reference guide for authorized, trained personnel. Each person involved in the operation, maintenance, and installation of the machine should read and thoroughly understand the instructions in this manual and follow ALL warnings.

Employers involved in the operation, maintenance, and installation of the machine should also read and understand the most current version of the following applicable standards:

ANSI STANDARD NO. Z245.2, "STATIONARY COMPACTORS SAFETY REQUIREMENTS"

A copy of this standard may be obtained from:

**ENVIRONMENTAL INDUSTRIES ASSOCIATION
4301 CONNECTICUT AVENUE, NW SUITE 300
WASHINGTON, D.C. 20008**

OSHA Standards - 29 CFR

Refer to:

- Part 1910.147: "The Control of Hazardous Energy (Lock-Out/Tag-Out)"
- Part 1910.212: "Machinery and Machine Guarding: General Requirements for all Machines"
- All other applicable OSHA Standards

ANY SERVICE OR REPAIRS THAT GO BEYOND THE SCOPE OF THIS MANUAL SHOULD BE PERFORMED BY FACTORY AUTHORIZED PERSONNEL ONLY!

If you should need further assistance, please contact your distributor. You will need to provide the equipment serial number, installation date, and electrical schematic number to your distributor.

If you have any safety concerns with the equipment or need further information, please contact us at:

**Marathon Equipment Company
P.O. Box 1798
Vernon, AL 35592-1798
Attn: Field Service Department
877-258-1105**

RamJet Self-Contained Compactor Container

General Information

PREFACE

The following sections are a guide for maintenance and service of the Marathon Equipment Company unit. The sections cover preventive maintenance, adjustment, and troubleshooting hints. Before performing maintenance, check the work area carefully to find all the hazards present and make sure all necessary safeguards or safety devices are used to protect all persons and equipment involved. In order to diagnose a problem quickly and effectively, a service person must be thoroughly familiar with the machine. This Operation, Service, and Installation Manual explains the system and its major components. Diagrams and schematics of the electrical and hydraulic systems are in the Service Section.



IMPORTANT!

- Before starting any maintenance, study this section of the manual.
- Read all hazard warnings and decals on the unit.
- Clear the area of other persons before performing any maintenance.
- Know and understand safe use of all controls.
- It is your responsibility to understand and follow manufacturer's instructions on equipment maintenance and care.

General Information

HAZARD SYMBOLS AND DEFINITIONS

Listed below are the definitions for the various levels of hazards. It is important that the operators of this equipment and people who service units read and understand all warnings as they relate to this equipment operation.

DANGER

DANGER – indicates an imminently hazardous situation, which WILL result in DEATH or SERIOUS INJURY if you don't follow proper instructions.

WARNING

WARNING – indicates an imminently hazardous situation, which COULD result in DEATH OR SERIOUS INJURY if you don't follow proper instructions.

CAUTION

CAUTION – indicates an imminently hazardous situation, which will result in MINOR to MODERATE INJURY if you don't follow proper instructions.

NOTICE

NOTICE – means unit or other property may be damaged if these instructions are not followed.

You must read and obey all warnings in any manual produced by Marathon Equipment Company to support your unit.

General Information

LOCK-OUT & TAG-OUT INSTRUCTIONS

DANGER



Before entering any part of the compactor, be sure that all sources of energy have been shut off, all potential hazards have been eliminated, and the compactor is locked-out and tagged-out in accordance with OSHA and ANSI requirements.

The specific Lock-Out and Tag-Out instructions may vary from company to company (i.e. multiple locks may be required, or other machinery may need to be locked-out and tagged-out). The following instructions are provided as minimum guidelines.

INSTRUCTIONS

1. Notify all affected employees that servicing or maintenance is required on the compactor and that the compactor must be shut down and locked out to perform the servicing or maintenance.
2. Perform a hazard assessment;
 - a. The authorized employee shall refer to the company procedure to identify the type and magnitude of the energy that the compactor utilizes, shall understand the hazards of the energy, and shall know the methods to control the energy.
3. Wear proper personal protective equipment.
4. If compactor is operating, it must be shut down by the normal stopping procedure. If the ram is pressing against a load, move the ram rearward before shutting the compactor down.
5. De-activate the energy isolating device(s) so that compactor is isolated from the energy source(s).
 - a. Shut down all power sources.
 - b. Move the main disconnect lever to the OFF position.
6. Lockout the energy isolating device(s) with assigned individual lock(s).
 - a. Padlock the disconnect lever with a keyed padlock and take the key with you.
 - b. Along with the padlock, place an appropriate, highly visible, warning tag on the disconnect lever. The tag should provide a warning such as:

“Danger: Do not operate equipment. Person working on equipment.” or
“Warning: Do not energize without the permission of _____.”
 - c. Place operating components in such a position so as not to be subject to possible free fall and/or install additional blocking devices to prevent this potential for any raised or elevated component.
7. Stored hydraulic energy must be removed from the compactor hydraulic circuit for complete Lock-Out and Tag-Out. Make sure that this energy has been relieved by manually depressing the solenoid valve pin located in the center of each coil end of the directional control valve.
8. After locking and tagging the compactor, ensure that the compactor is disconnected from the energy source by first checking that no personnel are exposed, then verify the isolation of the equipment by operating the push button or other normal operating control(s) or by testing to make certain the equipment will not operate. Try to start and operate the compactor (as outlined in the Operating Instructions) to make sure the Lock-Out and Tag-Out is effective. If the Lock-Out and Tag-Out is effective, remove the key from the key switch and take it with you.
9. Before entering compactor perform hazard assessment for confined space requirements (hazardous fumes, dust, toxic material, or other hazards) per the OSHA confined space standard.
10. The compactor is now locked out.

General Information

LOCK-OUT & TAG-OUT INSTRUCTIONS (CONTINUED)

RESTORING SERVICE

When the servicing or maintenance is completed and the compactor is ready to return to normal operating condition, the following steps shall be taken:

1. Check the compactor and the immediate area around the compactor to ensure that nonessential items have been removed and that the compactor components, guards and covers are operationally intact.
2. Check the work area to ensure that all employees have been safely positioned or removed from any hazardous area.
3. Verify that the controls are in neutral.
4. Remove the lockout devices and re-energize the compactor.

NOTICE

The removal of some forms of blocking may require re-energizing of the compactor before safe removal.

5. Notify affected employees that the servicing or maintenance is completed and the compactor is ready for use.
6. Reassess area to determine all hazards are protected.

RamJet Self-Contained Compactor Container

General Information

SPECIFICATIONS

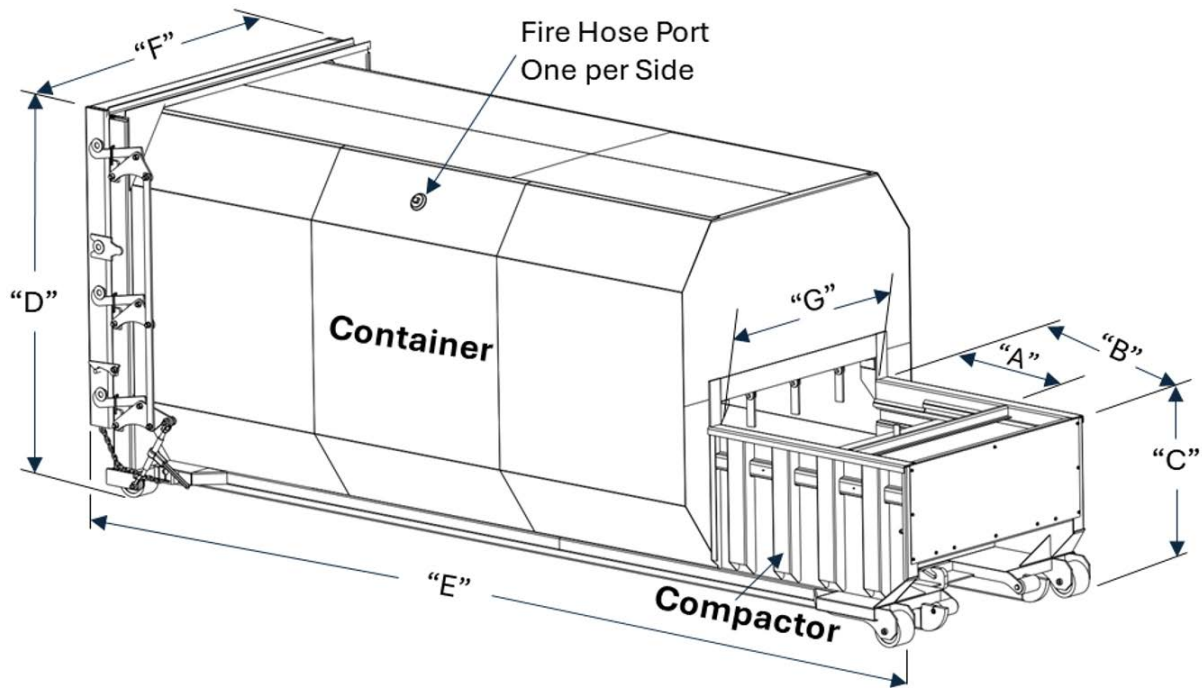

	RJ-88SC	RJ-100SC	RJ-250SC	RJ-250SC ULTRA	RJ-SC2
"A" Clear Top Opening (Length x Width) (inches)	30 1/2 X 48	35 X 60	41 1/2 X 58	41 1/2 X 58	40 1/2 X 56 1/2
"B" (inches)	70	76 1/8	67	67	67
"C" (inches)	43	48	48	48	48
"D" max (inches)	95*	104*	104*	104*	104*
"E" max (inches)	284 1/2*	290*	299 1/2*	269*	300 11/16*
"F" max (inches)	100 1/8"	100 1/8"	100 1/8"	100 1/8"	100 1/8"
Charge Box Capacity (cubic yards)	1.0	1.50	1.70	1.70	1.65
NWRA Rating (cubic yards)	0.70	1.32	1.31	1.31	1.25
Cycle Time (seconds)	44	37	33	33	37

*Determined by the size and capacity of the container.

RamJet Self-Contained Compactor Container

General Information

SPECIFICATIONS (CONTINUED)

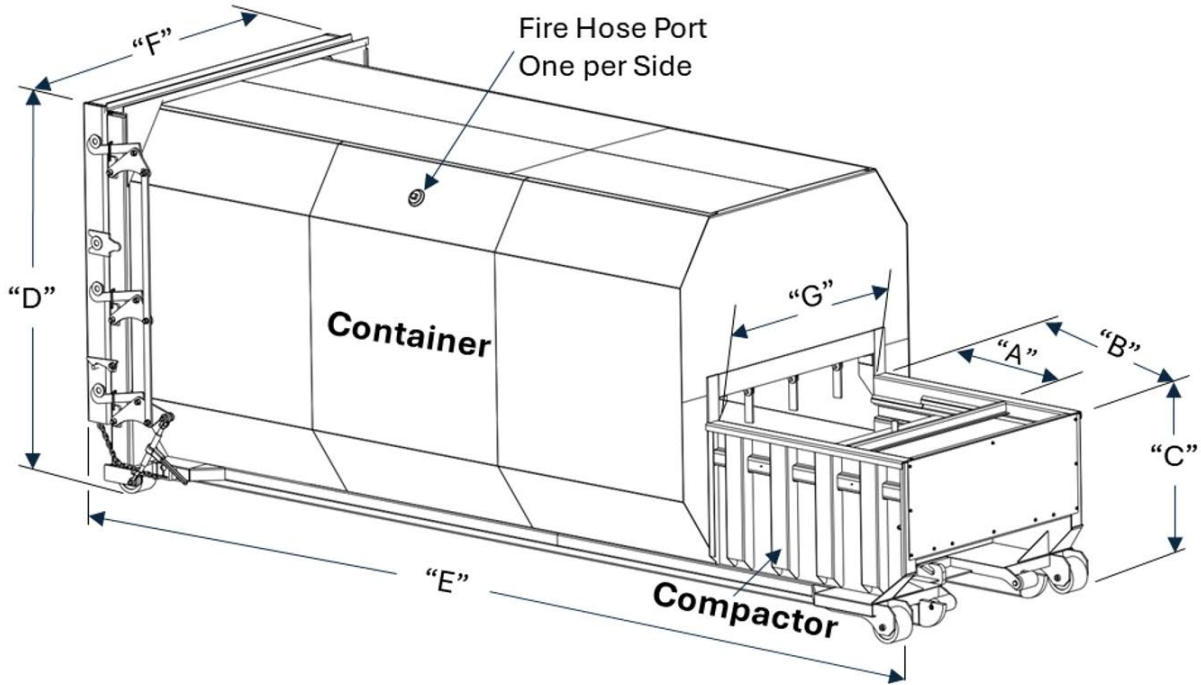

	RJ-250SC HT UNIV
"A" Clear Top Opening (Length x Width) (inches)	41 1/2 X 58
"B" (inches)	67
"C" (inches)	45
"D" max (inches)	101*
"E" max (inches)	253*
"F" max (inches)	100 1/8"
Charge Box Capacity (cubic yards)	1.70
NWRA Rating (cubic yards)	1.31
Cycle Time (seconds)	33

RamJet Self-Contained Compactor Container

General Information

SERVICE/PARTS ASSISTANCE

Assistance in troubleshooting, repair and service is available by contacting the authorized Marathon Equipment Company Dealer in your area. Parts are available at your Marathon Equipment Company Dealer or through Marathon Equipment Company. Marathon Equipment Company personnel are trained to give prompt, professional assistance.

ALWAYS give the machine serial number in all correspondence relating to the equipment.

GREASE LUBRICANT RECOMMENDATION

Use a grease gun. Before engaging grease gun, clean the fitting. Always pump enough grease to purge the joint of contaminated grease and wipe off the excess grease. Lubricate a unit as recommended on the lubrication decal on the unit and in the Operation, Service, and Installation Manual. Use NLGI 000 grease.

RECOMMENDED OILS

The following oils by brand name are approved for use in the hydraulic system on this equipment and considered to be all temperature hydraulic fluids.

- Union-UNAX-46, UNAX-AW46
- Gulf-Harmony 47, Harmony 48-AW
- Exxon-Teresstic 46, NUTO 46
- Texaco-Rando 46
- Chevron-AW 46
- Shell-Turbo 46, Tellus 46
- Citgo-Pacemaker 46, Tellus-AW46
- Conoco-Super Hydraulic Oil 46

Automatic Transmission Fluid (for 15 HP and smaller units only)

- Quaker State-Dextron II (ATF)

Cold Weather Fluid

- Amoco-Rycon MV

General Information

GUARDS AND ACCESS COVERS

Before operating or performing maintenance, check the work area carefully to find all the hazards present and make sure all guards and safety devices are in place to protect all persons and equipment involved.

WARNING

DO NOT operate without all guards and access covers in place.

WARNING DECALS ON THE UNIT

WARNING

DO NOT operate without all guards and access covers in place.

Make sure you can read all warning and instruction decals. Clean decals if you cannot read the words. See below for directions on cleaning decals. Replace any decal that is damaged, missing, or is not readable. When you replace a part that has a decal, make sure a new decal is installed on the new part. See the Operation, Service, and Installation Manual for replacement decals. Order replacement decals from Marathon Equipment Company or an authorized dealer.

RamJet Self-Contained Compactor Container

General Information

DECAL CARE

It is important that the decals are properly cleaned to make sure that they are readable and do not come off the unit. Use the following steps to clean the decals.

A. General Instructions

Following these instructions helps the decals adhere longer.

- Wash the decals with a blend of mild car wash detergent and clean water
- Rinse with clean water
- Let the unit air-dry or dry with a micro-fiber cloth
- Do not allow fuels to stay in contact with the decal for an extended period of time. Remove the fuel contamination as quickly as possible
- Do not use carnauba-based wax over the decals
- Do not use a mechanical brush while washing the decals.

B. Pressure Washer Precautions

Pressure washing can cause damage to decals. It can cause the edges of the decals to lift and peel the decal away from the unit. Over time, the decal can fade, crack or chip away.

Use pressure washing only when other cleaning methods are not effective. If you use a pressure washer, use the following precautions.

- Spray nozzle opening: 40° wide pattern
- Spray angle: 65° from unit's body
- Distance of nozzle to decal: 15" minimum
- Water pressure: less than or equal to 800 psi
- Length of time: not more than 30 sec.
- Do not use sharp angles to clean the decals – this can lift the decals from the unit.
- NEVER use a "turbo pressure nozzle".

C. Remove Difficult Debris

When normal cleaning procedures do not remove difficult debris from the decals, try the following:

- Spot clean the decal with Isopropyl Alcohol and a micro-fiber cloth (rag)
- If these methods do not work on a problem area, call a Marathon Equipment Company Dealer or Marathon Equipment Company Customer Support.

RamJet Self-Contained Compactor Container

General Information

DECAL CARE (CONTINUED)

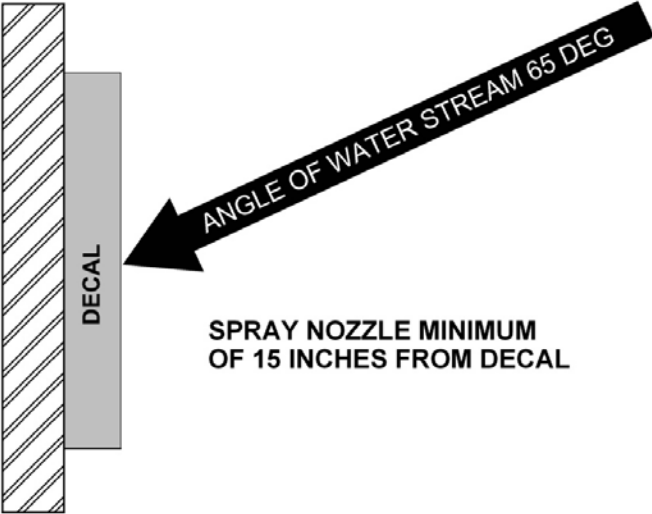

RECOMMENDED TECHNIQUE

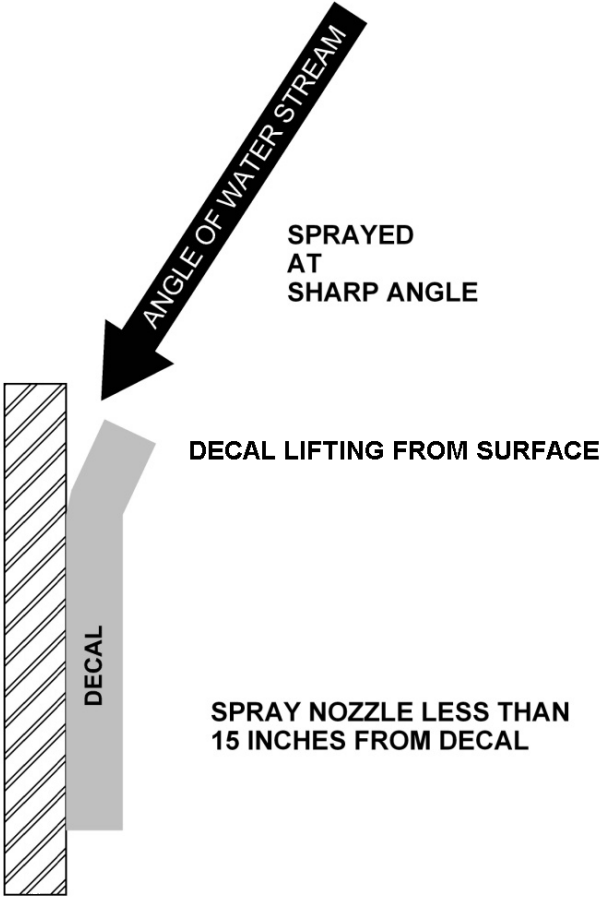

INCORRECT TECHNIQUE

RamJet Self-Contained Compactor Container

General Information

HYDRAULIC SYMBOLS

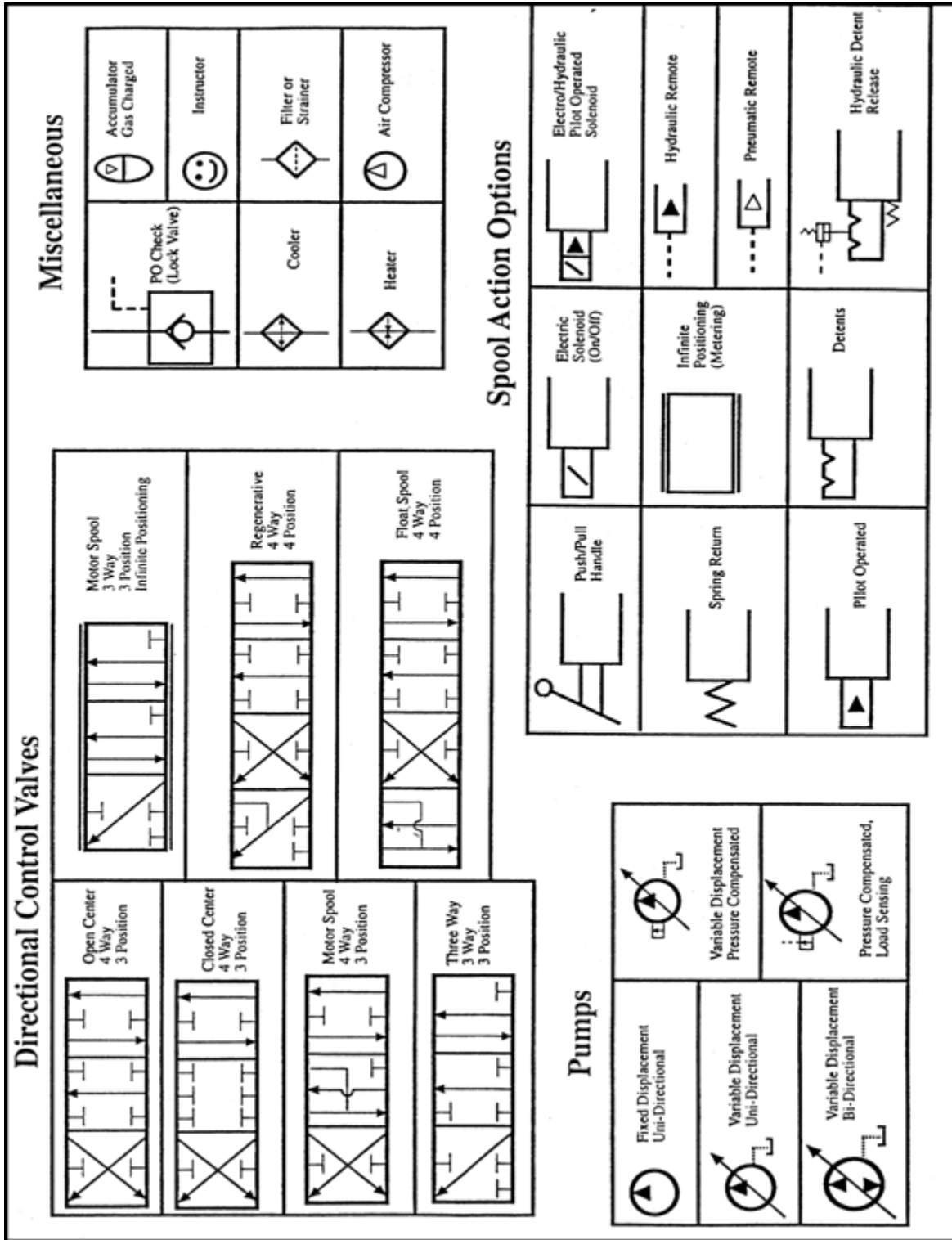

RamJet Self-Contained Compactor Container





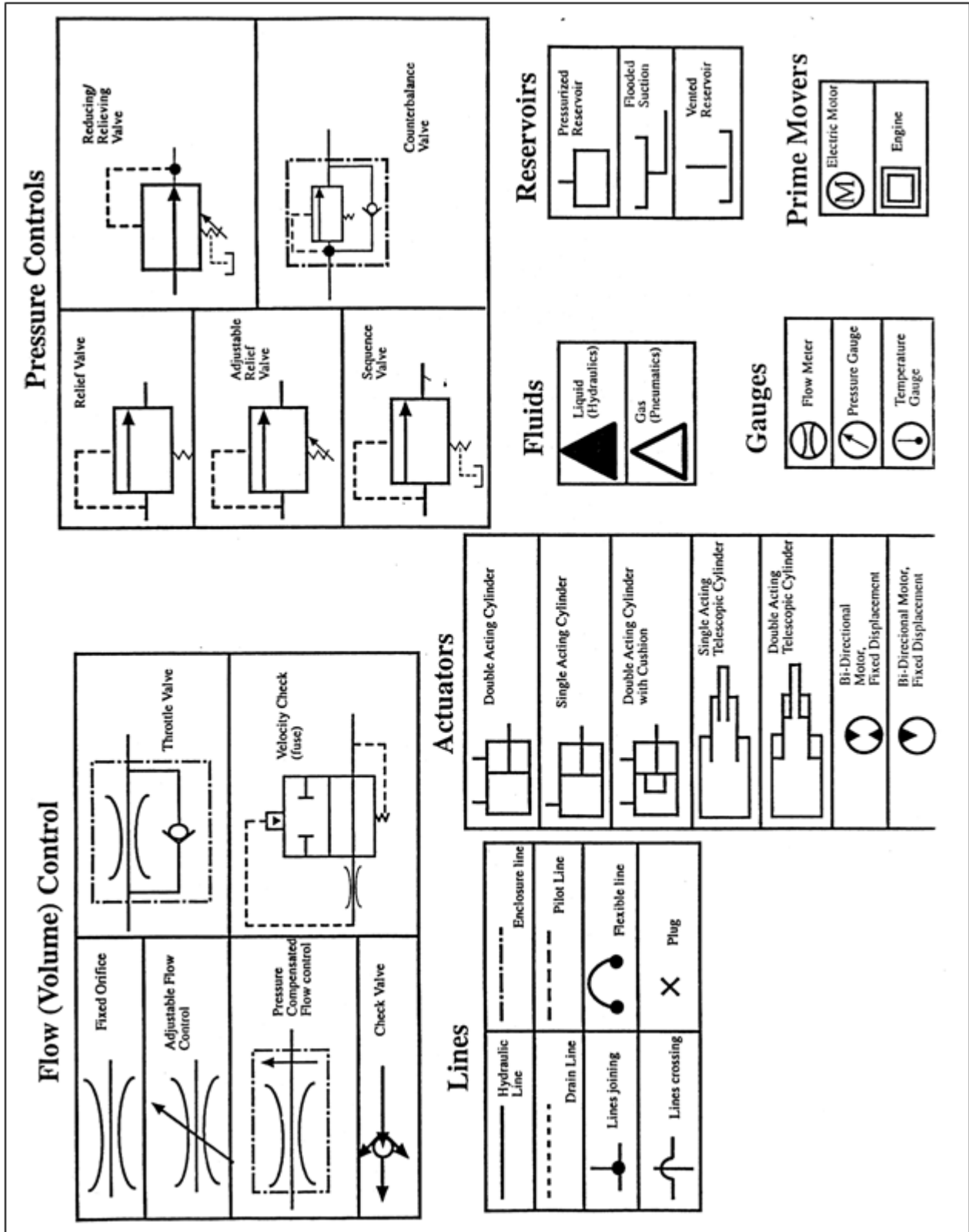







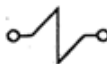

General Information

HYDRAULIC SYMBOLS (CONTINUED)



ELECTRICAL SYMBOLS

SYMBOL DEFINITIONS

	BATTERY
	FUSE
	SOLENOID
	CONTACT RELAY
	NORMALLY OPEN CONTACT OF CR1
	NORMALLY CLOSED CONTACT OF CR1
	INDICATOR LIGHT (GREEN)
	PUSH BUTTON SWITCH NORMALLY CLOSED
	PUSH BUTTON SWITCH NORMALLY OPEN
	TOGGLE SWITCH
	DIODE
	PRESSURE SWITCH
	LIMIT SWITCH NORMALLY OPEN
	LIMIT SWITCH NORMALLY CLOSED
	CAPACITOR

INTENTIONALLY LEFT BLANK

SECTION 2

INSTALLATION

RamJet Self-Contained Compactor Container Installation

20

CONTACT INFORMATION



Technical Service and Warranty:

877-258-1105

Parts:

800-528-5308

For parts visit our eCommerce Marketplace at www.mecomerchant.com.

If you do not have a user name and password, contact our Parts Department and they will assist with your registration.

Normal Business Hours:

Monday-Friday 8:00am - 5:00pm

(Central Standard Time)

RamJet Self-Contained Compactor Container

Installation

CONCRETE PAD REQUIREMENTS

These installation instructions are not intended as a substitute for training and experience in proper use and safety procedures in operating this equipment. Marathon Equipment Co. does not assume responsibility for the installation procedures of this equipment. Conformance to applicable local, state, and federal laws concerning installation rests with the customer.

CAUTION

Review this manual before making the installation. Study the job site and installation requirements carefully to be certain all necessary safeguards or safety devices are provided to protect all personnel and equipment during the installation and as a completed system. Special attention is directed to the most current ANSI Z245.2 standard.

Concrete Pad

1. Preferred dimensions of the concrete pad are 10'0" wide and a length of 5'0" greater than the length of the compactor/container. It should be level and of minimum 3000 PSI concrete steel reinforced, 6" thick. It is preferred that the concrete pad be flush with the surrounding ground level.

NOTICE

Units with four ground rollers must be installed on a level pad.

2. To provide accessibility, concrete pad should be positioned to allow 28" between machine and building wall if installed parallel with building. Allow a minimum of 45' of clear space from end of pad for container handling vehicle.

NOTICE

The clearances given are minimums. Your installation may require greater clearances depending on the site and the hauling equipment that will be used.

Container Guides

If container guides (optional) are used with the self-contained units, the guides should be anchored to the concrete pad with 3/4" X 6" (minimum) anchor bolts. These bolts should be concrete anchors or expansion type anchor bolts. To allow for construction variations, it is best if these holes are drilled in the concrete after pre-locating the container guides in their desired location. Drill holes and place anchor bolts in each location provided on the guides. When the guides have been placed in position, and the anchor bolts have set, tighten all nuts securely.

RamJet Self-Contained Compactor Container

Installation

STEEL INSTALLATION PROCEDURES

Dock Installation

If the appropriate accessories are ordered from Marathon Equipment Co., the compactor/ container will be furnished with either a four-sided hopper or a three-sided hopper with a hinged gate. THESE ACCESSORIES SHOULD NOT BE ALTERED AS THEY ARE MANUFACTURED IN ACCORDANCE WITH THOSE STANDARDS WHICH PREVAIL AT THE TIME OF MANUFACTURE.

If the compactor/container cannot be directly abutted to the dock or if there is any difference in height between the dock and the compactor/container, an appropriately sturdy transition section should be provided by the customer and securely affixed to the dock. Along with the transition section, a compactor/container guidance/stop mechanism should be installed to assure that the unit does not bottom out against the transition section or dock during dock placement (See ANSI Z245.2 Safety Standards). Optional container guides with stops are available from Marathon and are recommended for proper dock placement of the compactor/ container.

Chute-Fed Installation

Compactors installed in this arrangement are normally fed "through-the-wall". The lower edge of the access hole in the wall should be a MINIMUM of 42" (and, if possible, not more than 58") from the inside floor level. A security door (in accordance with local code) should be installed in the wall opening. In the absence of a local code, this door should be constructed of 3/16" thick steel or of steel hollow core design and be lockable from the inside of the building.

Decals

Be certain that the appropriate decals are in their proper locations at all times on the machine. For decal locations, see Decals [110](#) and Decals Placement [95](#) in the "Replacement Parts" section of this manual.

NOTICE

Installation is not complete until all decals are in place.

RamJet Self-Contained Compactor Container

Installation

ELECTRICAL AND HYDRAULIC INSTALLATION

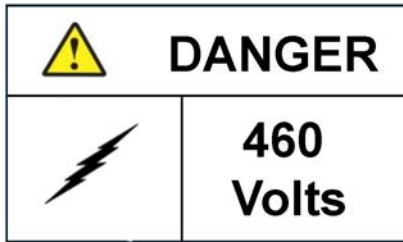

The motor control panel contains high voltage components. Only authorized service personnel should be allowed inside. See **Lock-Out & Tag-Out Instructions** ⁷ in the Service section.

A lockable fused disconnect switch (customer furnished) must be installed and be within sight of the compactor motor control panel location, not to exceed 50'0" from the compactor. This fused disconnect switch should be sized in accordance with the compactor (See **Fuses and Circuit Breakers** chart).

⚠ DANGER

All equipment must be grounded per National Electric Code.

Grounding Instructions: This appliance must be connected to a grounded, metal, permanent wiring system; or an equipment grounding conductor must be run with the circuit conductors and connected to the equipment grounding terminal or lead on the compactor.

If there is any doubt whether the appliance is properly grounded, a qualified electrician should be consulted.

Remote Power Pack Installation

1. The remote power pack should be installed and anchored as required by the customer. If the operator station is mounted in the face of the motor control panel, be certain these controls are located as to be in a convenient, but not hazardous, location to the customer.

⚠ CAUTION

Operator Station must be located so that the Emergency Stop Button is readily accessible to the operator and within three (3) feet of the charging chamber access door. If installation requires the operator station to be located in a more remote area, a second Emergency Stop Button should be added and installed in the manner described above.

2. For a through-the-wall power pack installation, see the diagram **Through-The-Wall Power Unit Installation** ²⁵ in this section. Special care should be taken to protect the hoses from abrasive objects.

Connect the hydraulic hoses to the power pack, exercising care to follow the port decals (A or B) on the packer and the power pack. In the event the decals have been obliterated, the hose leading from the rear of the cylinder should be installed in the side port of the block to which solenoid valve is bolted (A Port). The hose leading from rod end of the cylinder should be connected to the end of the block to which the solenoid valve is bolted (B Port). Refer to **Power Unit** ⁸⁶ diagrams in the Service section of this manual.

RamJet Self-Contained Compactor Container

Installation

ELECTRICAL AND HYDRAULIC INSTALLATION (CONTINUED)

Pushbutton Control Panel

If a remote operator station is furnished, it will be factory wired using Sealtite. If it is necessary to disconnect it from the wires (to install the operator station inside a building), exercise care that these wires are reconnected as originally furnished. (Check local codes to be certain that sealtite is acceptable.)

CAUTION

Operator Station must be located so that the Emergency Stop Button is readily accessible to the operator and within three (3) feet of the charging chamber access door. If installation requires this operator station to be located in a more remote area, a second Emergency Stop Button should be added and installed in the manner described above.

Electrical Connections

Run power lines, between fused disconnect switch (customer furnished) and compactor's motor control panel, in accordance with local electrical codes, using knock-outs in bottom of motor control panel. See **Fuses and Circuit Breakers** chart and **Wire Size** chart, in the Service section, to determine the proper service disconnect amperage rating and the proper wire size.

NOTICE

High legs should be installed to L3 on motor starter.

Check voltage at fused disconnect switch to be certain it is the same as is shown on compactor or remote power pack. If voltage is correct, put fused disconnect switch in "ON" position.

Start-Up Instructions

NOTICE

Make sure that the operators are trained in the proper use of this equipment prior to operation.

1. With the ram fully retracted, check to be sure the oil reservoir is full to the 3/4 level on the sight gauge (Refer to the maintenance chart for hydraulic oil recommendations). The hydraulic system pressure has been factory set and the entire unit has been operated prior to shipment.

CAUTION

Make sure persons and material are clear of charge box area.

2. Depress the start button and check the pump shaft for proper rotation.

CAUTION

If the pump rotates backward, stop immediately. The pump will be damaged if it is operated in reverse even for short periods. Reversing any two incoming power lines will change the motor/pump rotation.

3. Make sure that the operators are trained in the proper use of this equipment

RamJet Self-Contained Compactor Container Installation

THROUGH-THE-WALL POWER UNIT INSTALLATION

If the remote power unit is to be mounted through-the-wall, the following list of material and diagram is the suggested method.

LIST OF MATERIAL		
ITEM #	QTY	DESCRIPTION
1	2	Hydraulic Hose, Hi-Pressure (sized to power unit*), 36" long
2	2	Pipe, Schedule 80 (sized to power unit*), 36" long
3	2	Hydraulic Hose, Hi-Pressure (sized to power unit*), 48" long
4	2	Steel plate with holes for Item # 2, 3/16" x 8" x 12"
5	4	Coupling, Female (sized to fit hose & pipe*)
6	3	Quick disconnect

* 1/2" for hose lengths of 20'-0" or less. Consult factory for longer lengths.

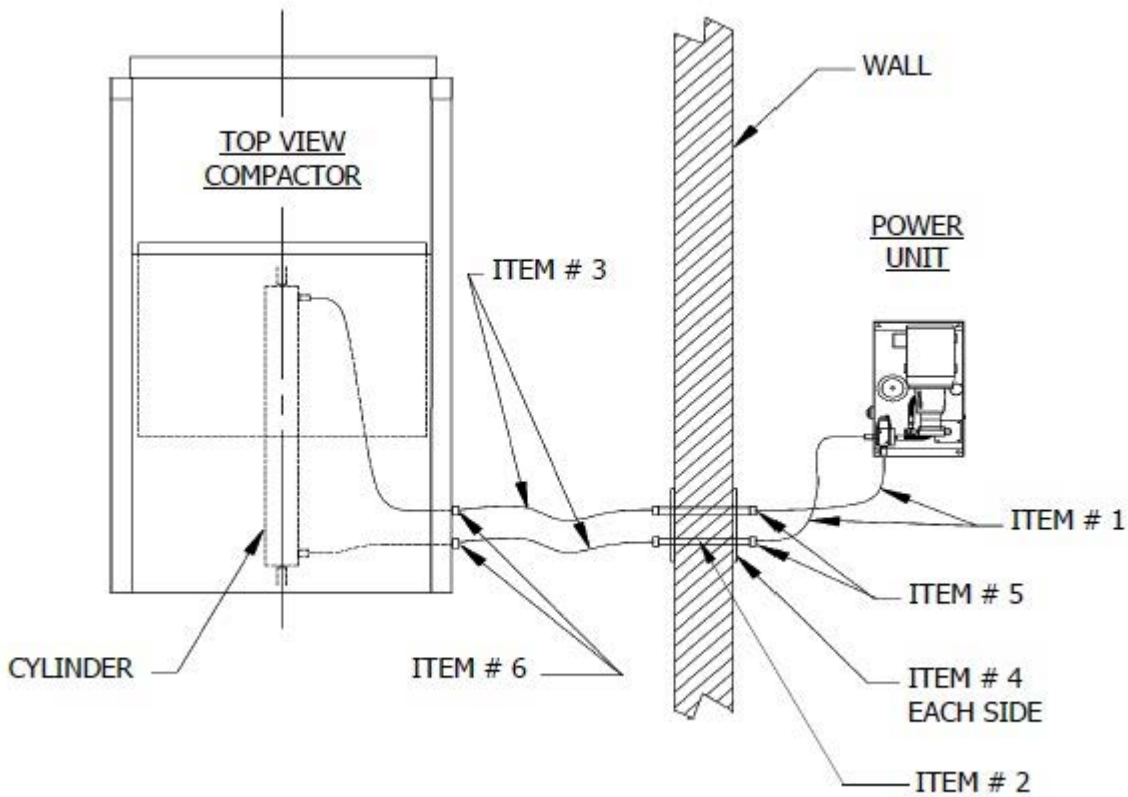

INTENTIONALLY LEFT BLANK

SECTION 3

OPERATION

RamJet Self-Contained Compactor Container Operation

28

CONTACT INFORMATION



Technical Service and Warranty:

877-258-1105

Parts:

800-528-5308

For parts visit our eCommerce Marketplace at www.mecomerchant.com.

If you do not have a user name and password, contact our Parts Department and they will assist with your registration.

Normal Business Hours:

Monday-Friday 8:00am - 5:00pm

(Central Standard Time)

RamJet Self-Contained Compactor Container

Operation

PRE-OPERATION INSTRUCTIONS

Employers should allow only authorized and thoroughly trained personnel to operate this compactor.

This compactor is equipped with a key operated locking system. Keys should be in possession of only authorized personnel. Turn off and remove the key after use.

DANGER

ONLY TRAINED AND AUTHORIZED PERSONNEL SHOULD BE ALLOWED INSIDE PANEL BOX. The panel box contains high voltage components. See **Lock-Out/Tag-Out Instructions** .

WARNING

Do not operate compactor until operating instructions are thoroughly understood. Wear safety glasses and gloves when operating this equipment.

WARNING

Stay clear of all internal compactor parts and all moving external compactor parts when in operation. Failure to do so could result in serious personal injury or death!

WARNING

Never enter any part of compactor unless the disconnect switch has been turned off, padlocked, and all stored energy sources have been removed. See **Lock-Out/Tag-Out Instructions** .

WARNING

Do not remove access covers except for servicing. Only trained and authorized service personnel should be allowed to service this equipment. All access doors on the compactor body should always be secured in place when the unit is operating. See **Lock-Out/Tag-Out Instructions** .

WARNING

Before starting compactor, be sure no one is inside. Be certain that everyone is clear of all operation points and pinch point areas before starting.

WARNING

If the compactor is equipped with a security gate or doghouse with security door, be sure that the security gate or door is closed before the compactor is started.

NOTICE

Federal regulation prohibits the use of this equipment by anyone under 18 years of age.

Operation

STANDARD CONTROL PANEL

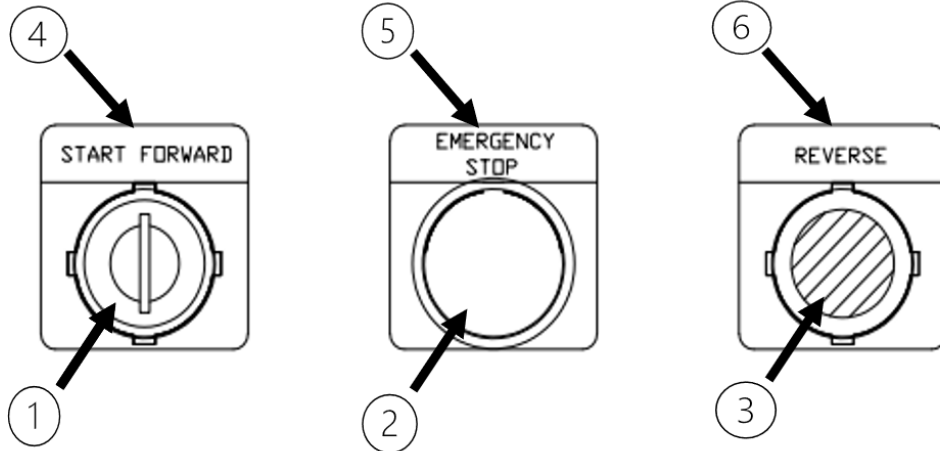

STANDARD CONTROL PANEL		
ITEM	PART #	DESCRIPTION
1	03-0195	KEY SWITCH
2	03-0201	EMERGENCY STOP
3	03-0197	REVERSE
4	03-0375	LEGEND "START FORWARD"
5	03-0193	LEGEND "EMERGENCY STOP"
6	03-0154	LEGEND "REVERSE"

CONTROL DESCRIPTION

1. **KEYED START SWITCH** - This switch requires a key for operation. Insert the key and turn clockwise to the START position. Depress the key for one to two seconds and release. The compactor will cycle one time (complete extension and retraction of the ram) then stop. After use, turn the key to the counterclockwise position and remove the key.
2. **EMERGENCY STOP PUSHBUTTON** - When depressed, this pushbutton will stop all powered operation of the compactor.
3. **REVERSE PUSHBUTTON** - This pushbutton will reverse the compaction ram when depressed. The motor must be running for the REVERSE button to operate. See the **Manual Override Instructions** [\[31\]](#) for details of the operation.

OPTIONAL CONTROLS

1. **SUSTAINED MANUAL PRESSURE CONTROL BUTTON** (Hold-To-Run, Release-To-Stop) This option requires the compactor operator to remain at the push button station while the compactor is in use. Actuation requires depressing the "Hold-To-Run" and "Start" buttons. After the unit has started, the "Start" button is released. If the "Hold-To-Run" button is released, the unit will stop instantly.
2. **ADVANCE WARNING / CONTAINER FULL LIGHT** - When the light starts flashing (ADVANCE WARNING), then 200 PSI is left before the pressure switch is activated to shut the unit off and container is full (unit will run when light flashes). When the light stays on continuously (CONTAINER FULL), the container is full and is ready to be emptied before its next use. To deactivate the light, depress the illuminated light (The unit will not run while the light is continuously on).
3. **ACCESS INTERLOCK** - This is required with units equipped with doors, security doors, or access gates. It prevents the unit from operating while a door or gate is open.

RamJet Self-Contained Compactor Container

Operation

CONTROL DESCRIPTION

1. **KEYED START SWITCH** - This switch requires a key for operation. Insert the key and turn clockwise to the START position. Depress the key for one to two seconds and release. The compactor will cycle one time (complete extension and retraction of the ram) then stop. After use, turn the key to the counterclockwise position and remove the key.
2. **EMERGENCY STOP PUSHBUTTON** - When depressed, this pushbutton will stop all powered operation of the compactor.
3. **REVERSE PUSHBUTTON** - This pushbutton will reverse the compaction ram when depressed. The motor must be running for the REVERSE button to operate. See the **Manual Override Instructions** ⁽³⁾ for details of the operation.

Operating Instructions - Standard Models7500-

1. First, place the material to be discarded into the compactor.
2. Insert the key into the key switch. Turn it clockwise and depress for 1 to 2 seconds and release. The unit will cycle the preset number of times determined by the Multi-Cycle Counter*, then stop.
3. Repeat, if necessary, after the compactor has stopped.
4. When you have finished using the compactor, remove the key from the key switch.

*For more information on the Multi-Cycle Counter see **PLC Maintenance**.

IN CASE OF EMERGENCY: Push the large RED button to STOP!

Manual Override Instructions (Ram Stop Rear Only)

If the ram is stopped in any position:

- To move the ram forward, turn the key switch clockwise and depress.
- To move the ram rearward, hold the reverse button down, turn and depress the key switch, release the key switch, then release the reverse button.

While the ram is moving:

- To reverse the ram while it is moving forward, press the reverse button.
- To cause the ram to move forward while it is moving rearward, depress the key switch.

NOTICE

Refer to Optional Controls for Manual Override on Ram Stop Forward Machines.

Operation

CONTROL PANEL WITH INTEGRAL DUMPER

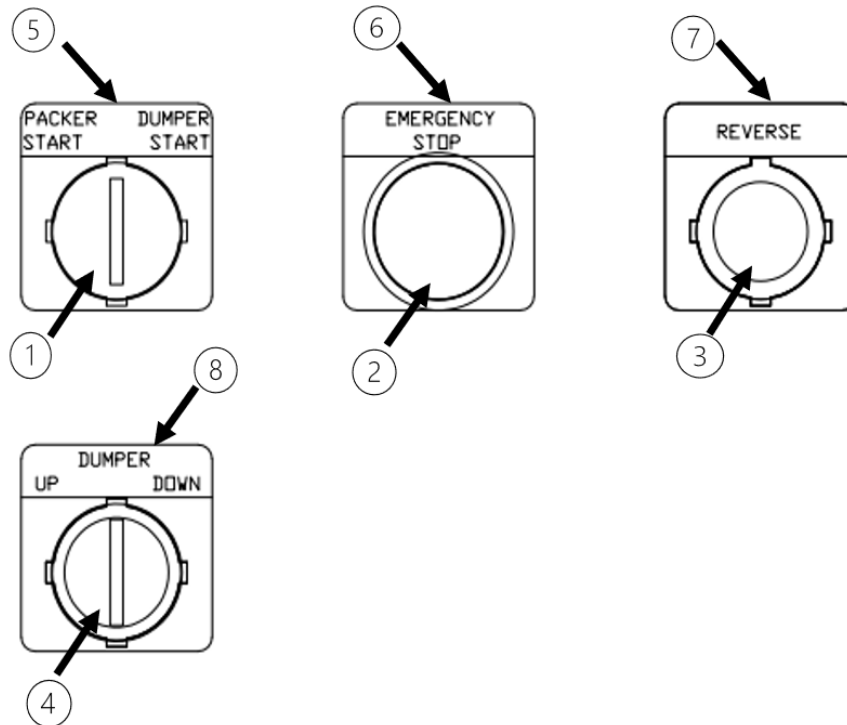

CONTROL PANEL WITH INTEGRAL DUMPER		
ITEM	PART#	DESCRIPTION
1	03-0382	KEY SWITCH
2	03-0201	EMERGENCY STOP
3	03-0197	REVERSE
4	03-0139	DUMPER UP/DOWN
5	03-1137	LEGEND "START PACKER DUMP"
6	03-0193	LEGEND "EMERGENCY STOP"
7	03-0154	LEGEND "REVERSE"
8	03-1522	LEGEND "DUMPER UP DOWN"

CONTROL DESCRIPTION WITH INTEGRAL DUMPER

- KEYED START SWITCH** - This switch requires a key for operation. Insert the key and turn left to START compactor. Turn and hold the key for one to two seconds and release. The compactor will cycle the preset number of times determined by the Multi-Cycle Counter*, then stop. Turn the key to the right to start dumper. Remove key in center.
- EMERGENCY STOP PUSHBUTTON** - When depressed, this pushbutton will stop all powered operation of the compactor.
- REVERSE PUSHBUTTON** - This pushbutton will reverse the compaction ram when depressed. The motor must be running for the REVERSE button to operate. See the **Manual Override Instructions** [\[31\]](#) for details of the operation.
- DUMPER UP/DOWN** - This manually controls the direction of the dumper.

*For more information on the Multi-Cycle Counter see PLC Maintenance page [\[67\]](#).

RamJet Self-Contained Compactor Container

Operation

OPERATING INSTRUCTIONS - STANDARD MODELS WITH INTEGRAL DUMPER

1. First, place the material to be discarded into the compactor.

NOTICE

If you are loading the compactor through a door or gate, close it before starting the compactor. Refer to "Optional Loading Configurations" on page 13 to determine how your compactor is configured.

2. Insert the key into the key switch. Turn to left for 1 to 2 seconds and release. The unit will cycle the preset number of times determined by the Multi-Cycle Counter*, then stop.
3. Repeat, if necessary, after the compactor has stopped.
4. When you have finished using the compactor, remove the key from the key switch.
5. Insert the key into the keyswitch and turn right to start dumper.
6. Turn the UP/DOWN switch to the UP position and hold to raise and empty the dumper/cart.
7. When the cart is empty, turn the UP/DOWN switch to the DOWN position and hold to lower the dumper/cart.
8. After use, depress the STOP button and remove the key. The key should always be in the possession of authorized personnel.

*For more information on the Multi-Cycle Counter see **PLC Maintenance** .

IN CASE OF EMERGENCY: Push the large RED button to STOP!

Manual Override Instructions (Ram Stop Rear Only)

If the ram is stopped in any position:

- To move the ram forward, turn the key switch to the left.
- To move the ram rearward, hold the reverse button down, turn the key switch to the left, release the key switch, then release the reverse button.

While the ram is moving:

- To reverse the ram while it is moving forward, press the reverse button.
- To cause the ram to move forward while it is moving rearward, turn the key switch to the left.

NOTICE

Refer to Optional Controls for Manual Override on Ram Stop Forward Machines.

NOTICE

Refer to Optional Controls for Manual Override on Ram Stop Forward Machines.

INTEGRAL DUMPER SYSTEM OPERATING CHARACTERISTICS

When the key is inserted into the key switch, turn right, a contact is made that energizes the motor starter, starting the electric motor which rotates the hydraulic pump. At the same time, the UP/DOWN switch is energized. This switch is spring-centered and is connected to the solenoid on each end of the control valve. Also, when the UP/DOWN switch is energized, T1 timer begins counting for 5 minutes. If the dumper sits idle for 5 minutes, the timer will time out and T1 timer contact will open which will shut down the power unit.

When the UP/DOWN switch is turned to the UP position and held, the valve solenoid shifts the valve spool so that the hydraulic oil is directed to extend the cylinders which raises the dumper forks (or box). When the UP/DOWN switch is turned to the DOWN position and held, the valve solenoid shifts the valve spool so that the hydraulic oil is directed to retract the cylinders which lowers the dumper forks (or box).

The EMERGENCY STOP button will shut the dumper down when depressed by breaking the circuit to the motor starter.

Always remove the key from the key switch when the dumper is not in use.

RamJet Self-Contained Compactor Container

Operation

CONTROL PANEL - MODELS WITH PHOTOELECTRIC CYCLE CONTROL

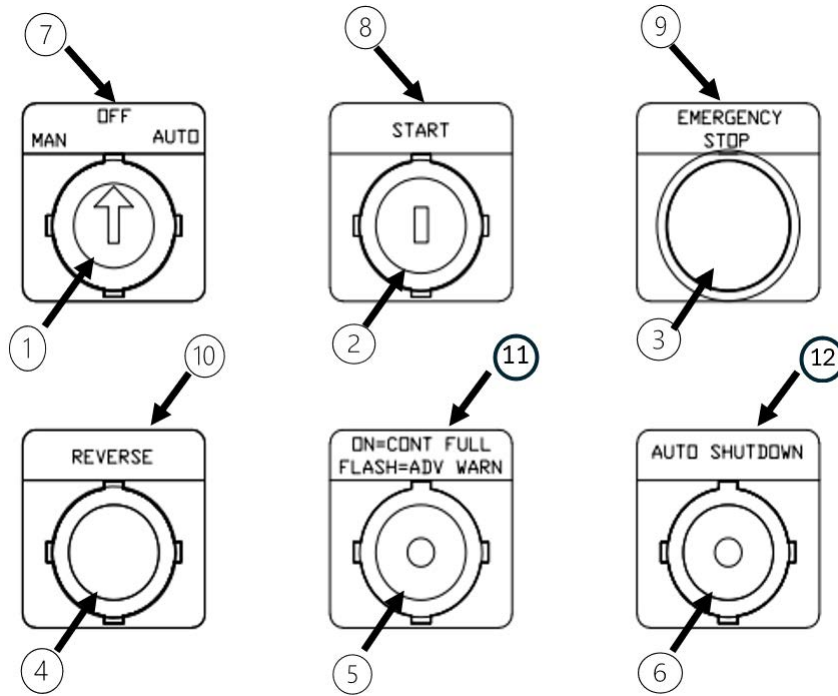

CONTROL PANEL WITH PHOTOELECTRIC CYCLE		
ITEM	PART#	DESCRIPTION
1	03-0199	KEY SWITCH
2	03-0195	KEY SWITCH
3	03-0201	EMERGENCY STOP
4	03-0197	REVERSE
5	03-0081	RED LIGHT
6	03-0081	RED LIGHT
7	99-5045	LEGEND "MAN/OFF/AUTO"
8	03-0375	LEGEND "START FORWARD"
9	03-0193	LEGEND "EMERGENCY STOP"
10	03-0154	LEGEND "REVERSE"
11	03-5473	LEGEND "ON = CONT FULL"
12	03-0350	LEGEND "AUTO SHUTDOWN"

RamJet Self-Contained Compactor Container

Operation

CONTROL DESCRIPTION

1. **MANUAL-OFF / AUTOMATIC SHUTDOWN** - This switch controls the compactor operation mode, manual or automatic (automatic is photocell mode).
 2. **KEYED START SWITCH** - This switch requires a key for operation. Insert the key and turn clockwise to the START position. Depress the key for one to two seconds and release. The compactor will cycle the preset number of times determined by the Multi-Cycle Counter, then stop. After use, turn the key to the counterclockwise position and remove the key.
 3. **EMERGENCY STOP PUSHBUTTON** - When depressed, this pushbutton will stop all powered operation of the compactor.
 4. **REVERSE PUSHBUTTON** - This pushbutton will reverse the compaction ram when depressed. The motor must be running for the REVERSE button to operate. See the **Manual Override Instructions** [\[31\]](#) for details of the operation.
 5. **ADVANCE WARNING / CONTAINER FULL LIGHT** - When the light starts flashing (ADVANCE WARNING), then 200 PSI is left before the pressure switch is activated to shut the unit off and container is full (unit will run when light flashes). When the light stays on continuously (CONTAINER FULL), the container is full and is ready to be emptied before its next use. To deactivate the light, depress the illuminated light (the unit will not run while the light is continuously on).
 6. **AUTOMATIC SHUTDOWN LIGHT** - Used with the photoelectric cycle control. If a blockage in the charge chamber causes the compactor to continue cycling, the timer will shut the compactor down after the preset time has passed. To deactivate the timer, the illuminated pushbutton is pressed after clearing the blockage.
- *For more information on the Multi-Cycle Counter, see **PLC Maintenance** [\[67\]](#).

RamJet Self-Contained Compactor Container

Operation

OPERATING INSTRUCTIONS - MODELS WITH PHOTOELECTRIC CYCLE CONTROL

NOTICE

This compactor features an ANSI Z245.21 (2013) SECTION 5.12.1 compliant start-up alarm that is both audible and visible during the activation of the AUTOMATIC mode.

Operating Instructions (Automatic Mode)

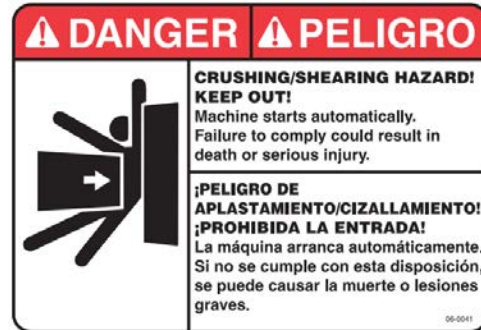
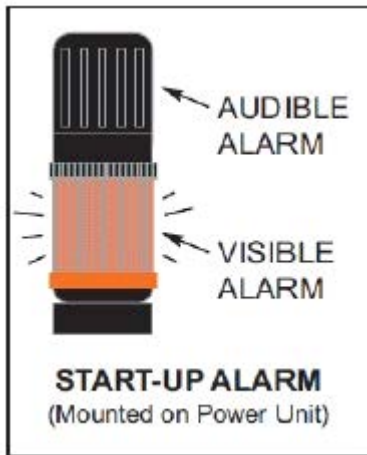

1. Place the material to be discarded into the compactor.

NOTICE

If you are loading the compactor through a door or gate, close it before starting the compactor.

2. Insert the first key into the "MANUAL - OFF - AUTOMATIC" key switch and turn to the "AUTOMATIC" position.
3. Insert the second key into the "START" switch and turn to the right.
4. Depress the key in the "START" switch and hold it continuously for 20 seconds.
 - Both the audible and visual start-up alarms will energize for 5 seconds.
 - After 5 seconds the audible alarm will stop, but the visual alarm will continue for an additional 15 seconds (for a total of 20 seconds).
 - After 20 seconds, the motor will start and the ram will extend, then retract (one complete cycle).
 - The light will continue to flash until the unit is manually turned off, automatically shuts down, or is switched to manual mode.



WARNING

In AUTOMATIC mode, the power unit will restart the ram automatically anytime the photocell detects ANY OBJECT in the charge box.

Operation

OPTIONAL CONTROLS

1. **SUSTAINED MANUAL PRESSURE CONTROL BUTTON (Hold-To-Run, Release-To-Stop)** This option requires the compactor operator to remain at the push button station while the compactor is in use. Actuation requires depressing the "Hold-To-Run" and "Start" buttons. After the unit has started, the "Start" button is released. If the "Hold-To-Run" button is released, the unit will stop instantly.
2. **ADVANCE WARNING / CONTAINER FULL LIGHT** - When the light starts flashing (ADVANCE WARNING), then 200 PSI is left before the pressure switch is activated to shut the unit off and container is full (unit will run when light flashes). When the light stays on continuously (CONTAINER FULL), the container is full and is ready to be emptied before its next use. To deactivate the light, depress the illuminated light (The unit will not run while the light is continuously on).
3. **RAM STOP FORWARD** - When a machine with this option has been stopped, the ram automatically begins to move rearward when restarted. To move the ram forward (when it is stopped), hold the FORWARD button down, turn the key switch clockwise, depress and release the key switch, then release the FORWARD button. To reverse the ram while it is moving forward, depress the key switch. To cause the ram to move forward while it is moving rearward, press the FORWARD button.
4. **ACCESS INTERLOCK** - This is optional with units equipped with doors, security doors, or access gates. It prevents the unit from operating while a door or gate is open.
5. **PHOTOELECTRIC CYCLE CONTROL - (Photocell)** - Consists of a LED light source and a reflector. It can be mounted on a hopper or chute. Two holes, located so as to avoid any hazard, are located in opposite walls of the chute. When the light beam is blocked for 5 seconds, the audible alarm will sound for 5 more seconds, then the compactor is activated and will continue to run until the obstruction has been cleared or the watchdog timer times out.
6. **AUTOMATIC SHUTDOWN** - Used with the photoelectric cycle control. If a blockage in the charge chamber causes the compactor to continue cycling, the timer will shut the compactor down after the preset time has passed. To deactivate the timer, the illuminated auto shutdown pushbutton is pressed after clearing the blockage.
7. **THERMOSTATICALLY CONTROLLED OIL HEATER** - This option is installed in the oil reservoir. The thermostat is adjustable so the heater will heat the oil when the oil temperature goes below a specified level. It is recommended to set the thermostat between 70° F - 100° F.
8. **START ON DOOR CLOSURE** - When switch is in auto the PLC counts door closures. The machine will start on predetermined count that is within the PLC.

INTENTIONALLY LEFT BLANK

SECTION 4

HAULER INFORMATION

RamJet Self-Contained Compactor Container

Hauler Information

HAULER INSTRUCTIONS – GENERAL

Before hauling to the dump site:

1. Disconnect all hoses and electrical connections (if applicable) between the power unit and the compactor. Make sure they are placed in an area where they will not get damaged.
2. Close and secure any hopper doors or gates.
3. Make sure that the container tailgate safety chain is secured in the keyhole on the latch side of the container floor. See **Securing Tailgate into Chain Keeper** ^[41].
4. If the unit is a Streamline® model (SL), disconnect any drain hose(s) connected to the unit and plug all ports. See **Liquid Removal for Optional SL Units** ^[48].
5. Make sure that the hoist lifting the unit is compatible with the understructure on the unit.
6. For units with integral dumpers, operate dumper to full dump position. See **Integral Dumper Operation** ^[49].

NOTICE

Hold downs should be used to secure the front and rear of the of the container understructure to the hoist.

At the dump site:

See **Securing Tailgate into Chain Keeper** ^[41], **Tailgate/Latch Operation** ^[43] and **Hydraulic Tailgate Operation** ^[45].

1. To prevent leakage, the tailgate seal and mating surface should be wiped clean and inspected after the unit has been emptied. When cleaning the seal on units with the hydraulic tailgate option, inspect for damage and replace if necessary.

WARNING

Never place any part of your body between the tailgate and the container. Use a mop or similar cleaning device with a long handle to clean the seal. Close inspection of the seal should be done only after the container has been lowered to a level position and the raised tailgate has been supported with a crane, forklift, or other positive maintenance prop.

2. Make sure all personnel are clear of the area around the compactor and the tailgate while being emptied.

After returning from the dump site:

1. After setting the unit down, reconnect all hoses and electrical connections (if applicable) to the compactor. Make sure they are not laying across sharp corners or any abrasive surface.
2. Close and secure any hopper doors or gates.
3. Make sure that the container tailgate safety chain is secured in the keyhole on the latch side of the container floor.
4. If the unit is a Streamline model (SL), connect a compatible drain hose(s) to the unit.

RamJet Self-Contained Compactor Container

Hauler Information

SECURING TAILGATE CHAIN INTO CHAIN KEEPER

1. Open tailgate fully and swing it around until it abuts the side of the container.

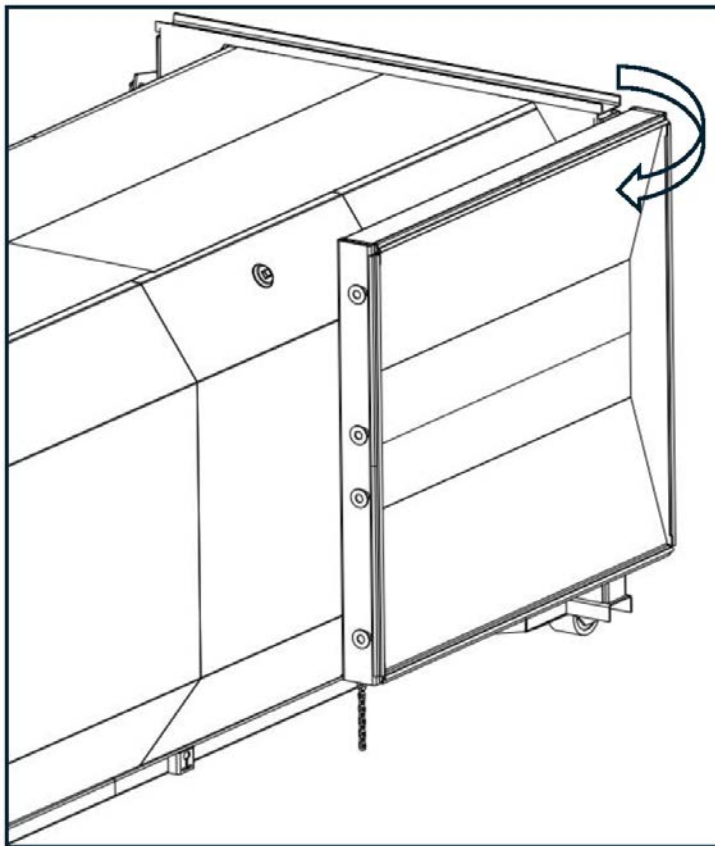

2. Insert chain into hole in chain keeper and pull chain through the keeper until tight.

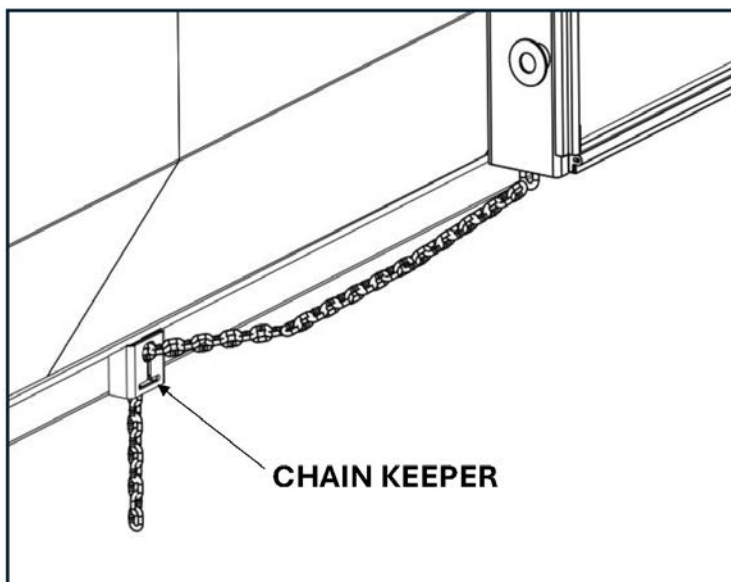

RamJet Self-Contained Compactor Container

Hauler Information

SECURING TAILGATE CHAIN INTO CHAIN KEEPER (CONTINUED)

3. Slide chain down into vertical chain keeper slot.

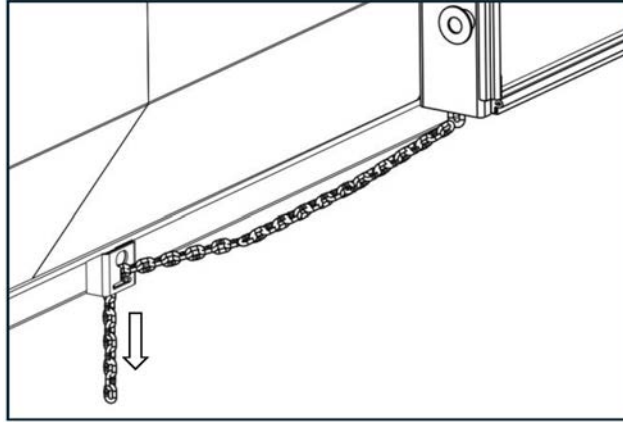

4. Turn chain and slide it into horizontal slot toward tailgate end of the container

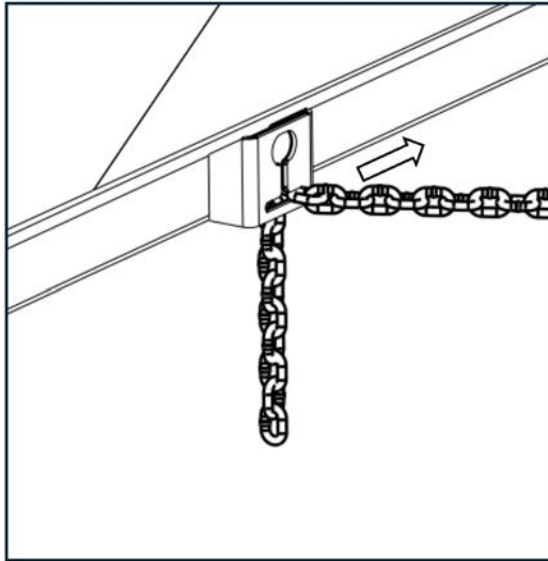

5. Ensure chain link is fully secured into horizontal door slot toward tailgate.

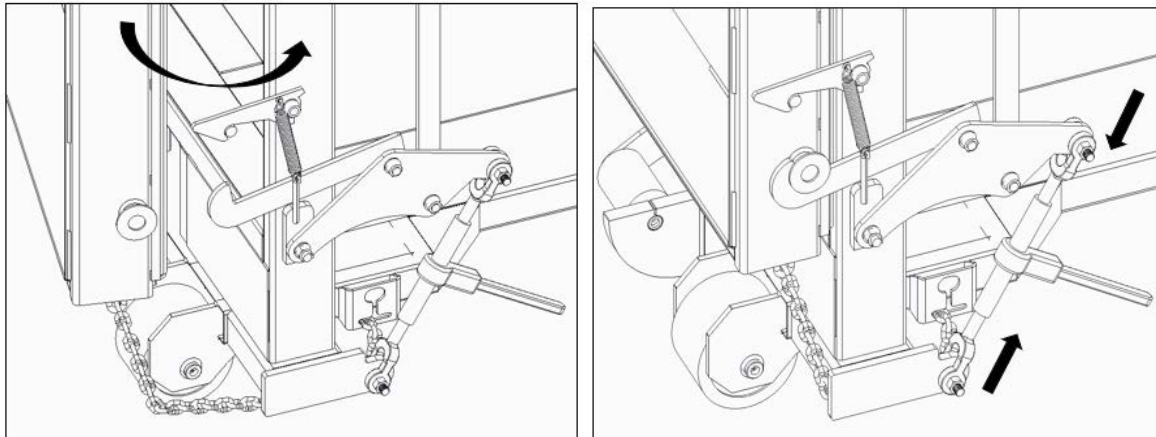

6. Ratchet latch side of container shown with chain engaged into chain keeper.

RamJet Self-Contained Compactor Container

Hauler Information

TAILGATE/LATCH OPERATION

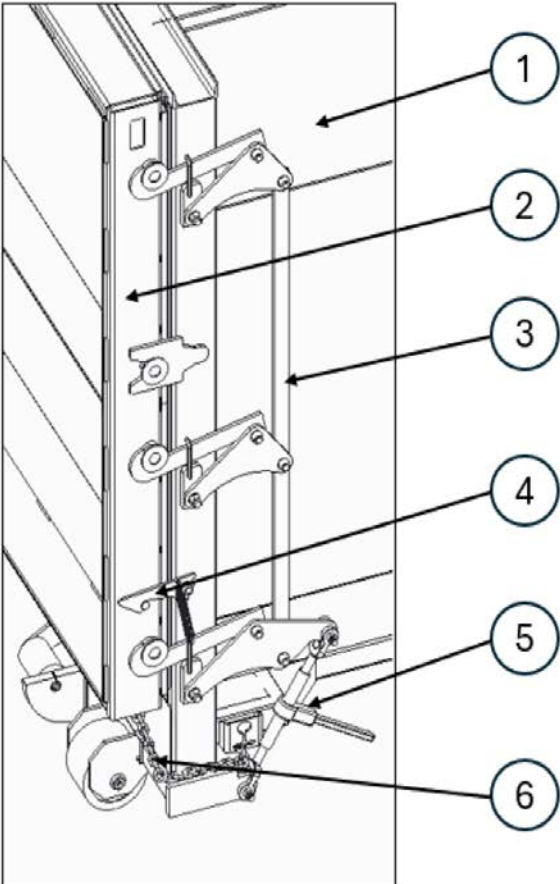

ITEM NUM	DESCRIPTION
1	CONTAINER
2	TAILGATE
3	LATCH ASSEMBLY ACTUATED BY RATCHET
4	AUTO RELATCH
5	RATCHET FOR OPENING AND CLOSING THE LATCH ASSEMBLY
6	TAILGATE CHAIN - ALWAYS FASTEN CHAIN IN KEYHOLE WHEN TAILGATE IS CLOSED.WHEN THE TAILGATE IS OPEN, SECURE THE CHAIN IN THE KEYHOLE ON THE HINGE SIDE OF THE CONTAINER FLOOR.

RamJet Self-Contained Compactor Container

Hauler Information

TAILGATE/LATCH OPERATION (CONTINUED)

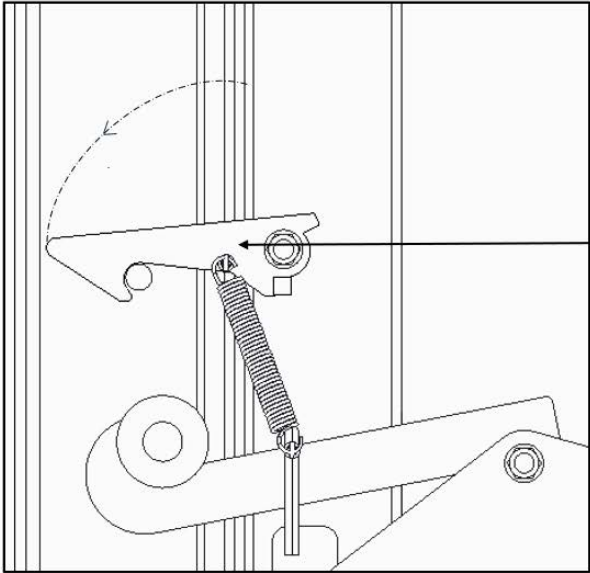
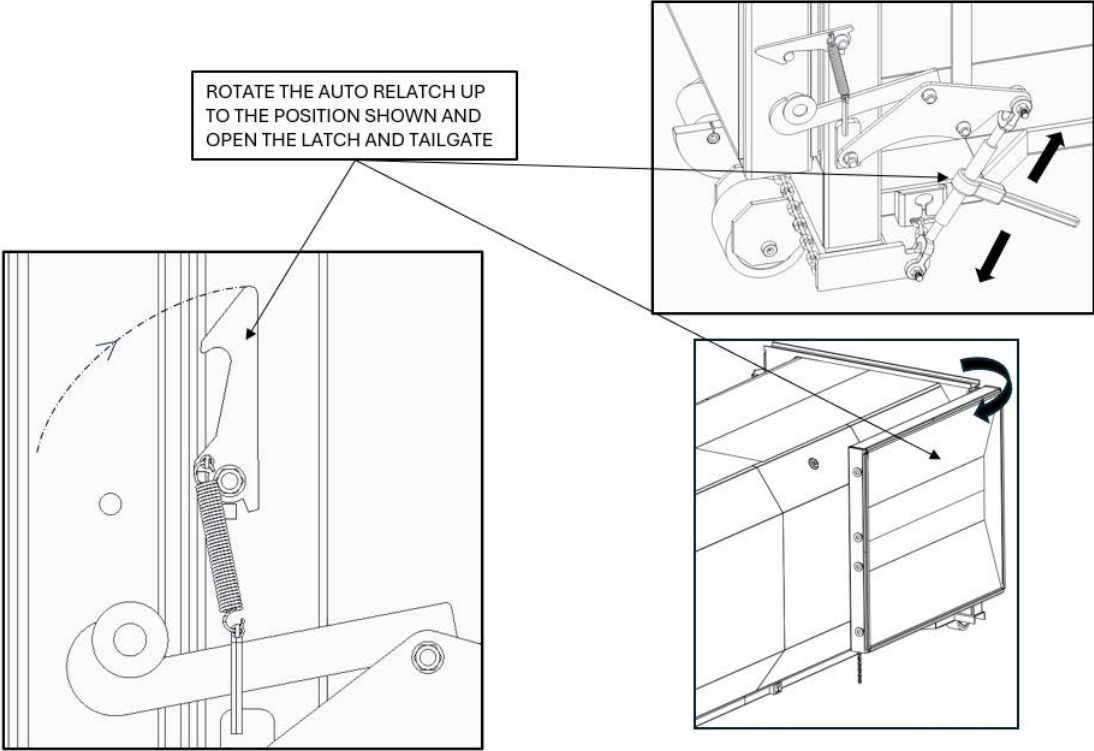

- WHEN CLOSING THE TAILGATE, ROTATE THE AUTO RELATCH DOWN TO THE POSITION SHOWN AND PUSH THE TAILGATE SHUT UNTIL THE AUTO RELATCH GRABS THE PIN ON THE TAILGATE.
- AFTER THE TAILGATE IS SECURED BY THE AUTO RELATCH, THE LATCH ASSEMBLY IS CLOSED USING THE RATCHET.
- CONNECT THE TAILGATE CHAIN ON THE TAILGATE TO THE KEYHOLE ON THE SIDE OF THE CONTAINER FLOOR.

RamJet Self-Contained Compactor Container

Hauler Information

HYDRAULIC TAILGATE OPERATION FOR OPTIONAL HT UNITS

The truck hoist must have a hydraulic selector valve with 1500 psi, min. to operate the hydraulic tailgate. The hydraulic tailgate is supplied with one 1/2" NPTF male quick disconnect mounted on the drivers side of the unit. A 1/2" female quick disconnect is supplied for use on the truck hoist valve plumbing.

CAUTION

- Stand clear of tailgate when lifted.
- Truck must be on firm, level surface before lifting tailgate.
- Front and rear holddowns must be engaged.
- Tilt hoist before lifting tailgate.

1. Attach hydraulic connection.
2. Disengage latch (each side).

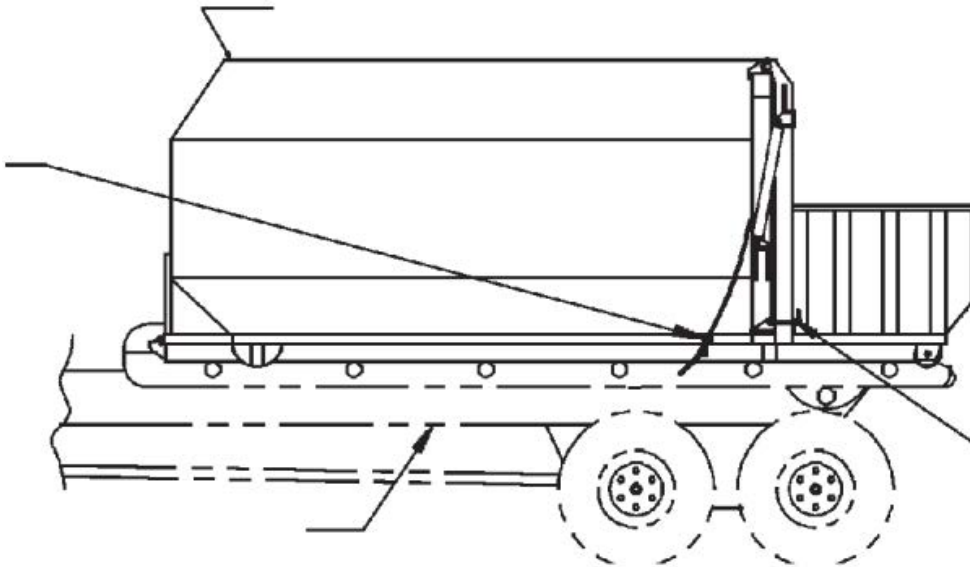

3. Raise hoist.



RamJet Self-Contained Compactor Container

Hauler Information

HYDRAULIC TAILGATE OPERATION FOR OPTIONAL HT UNITS (CONTINUED)

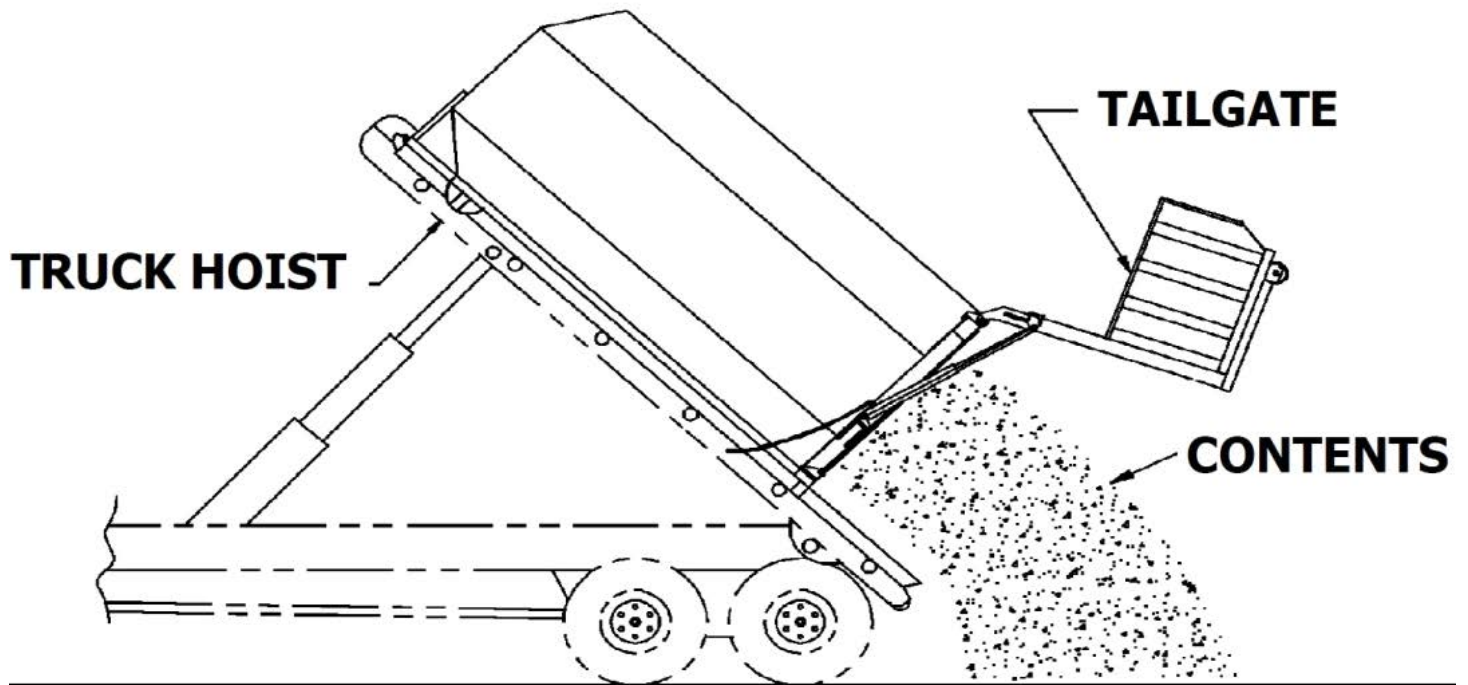

1. Lift tailgate.
2. Empty contents.
3. Clean seal as described in the "**Hauler Instructions - General**". [40](#)
4. Lower tailgate as low as possible.
5. Lower hoist.
6. Lower tailgate completely.
7. Engage and tighten latches.
8. Remove hydraulic connection.

RamJet Self-Contained Compactor Container

Hauler Information

HYDRAULIC TAILGATE OPERATION FOR OPTIONAL HT UNITS (CONTINUED)

⚠ WARNING

Never place any part of your body between the tailgate and container.

Instructions for using maintenance bar

1. Lower tailgate approximately 24" between container bottom and compactor tailgate.
2. Remove locking pin from maintenance bar and slide bar toward compactor.
3. Align holes in the position collar and bar and insert pin.
4. Use a mop or similar cleaning device with a long handle to clean the seal.
5. Raise tailgate to relieve pressure on maintenance bar, remove pin, return bar to retracted position and insert pin through collar and bar.

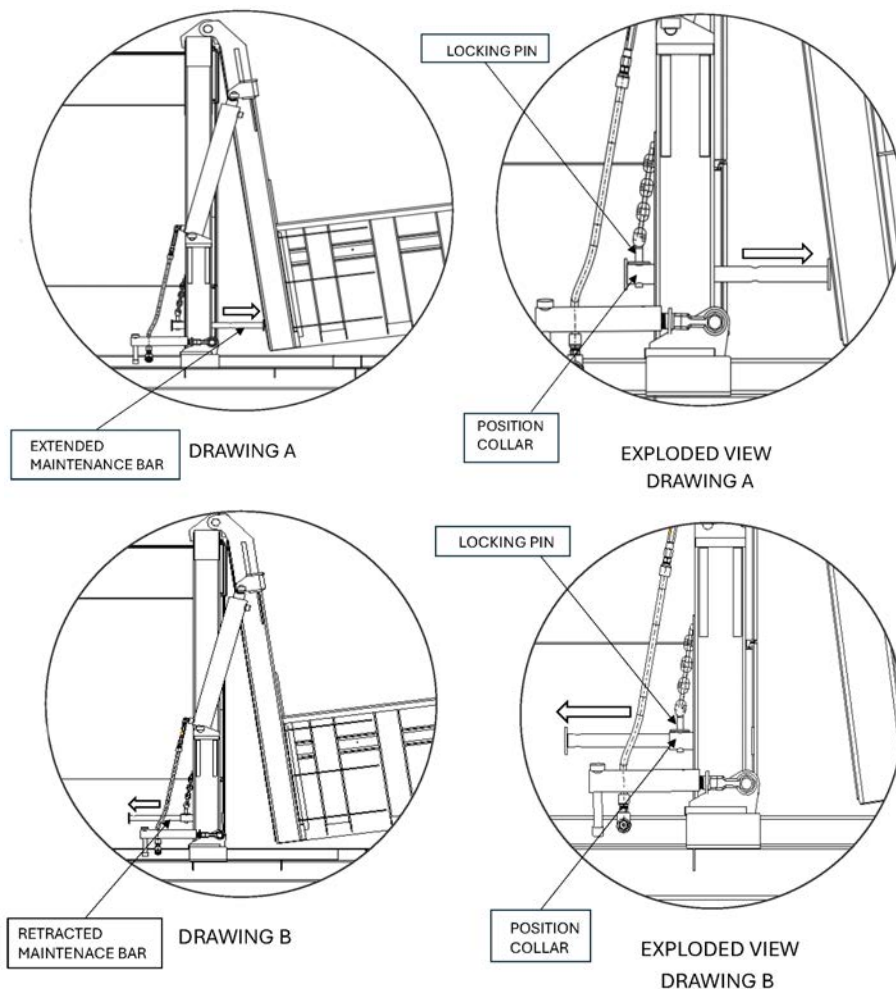

RamJet Self-Contained Compactor Container

Hauler Information

LIQUID REMOVAL FOR OPTIONAL SL UNITS

The RamJet Self-Contained Streamline® compactor/containers are designed with an internal drain system for liquid removal, ported to each corner of the machine. The unit comes standard with one ball valve. This valve can be moved to any of the four drain outlets on the machine. The valve should be located at the lowest outlet on the machine for proper drainage. The customer can attach a drain hose with a 3" NPT male fitting to the drain valve.

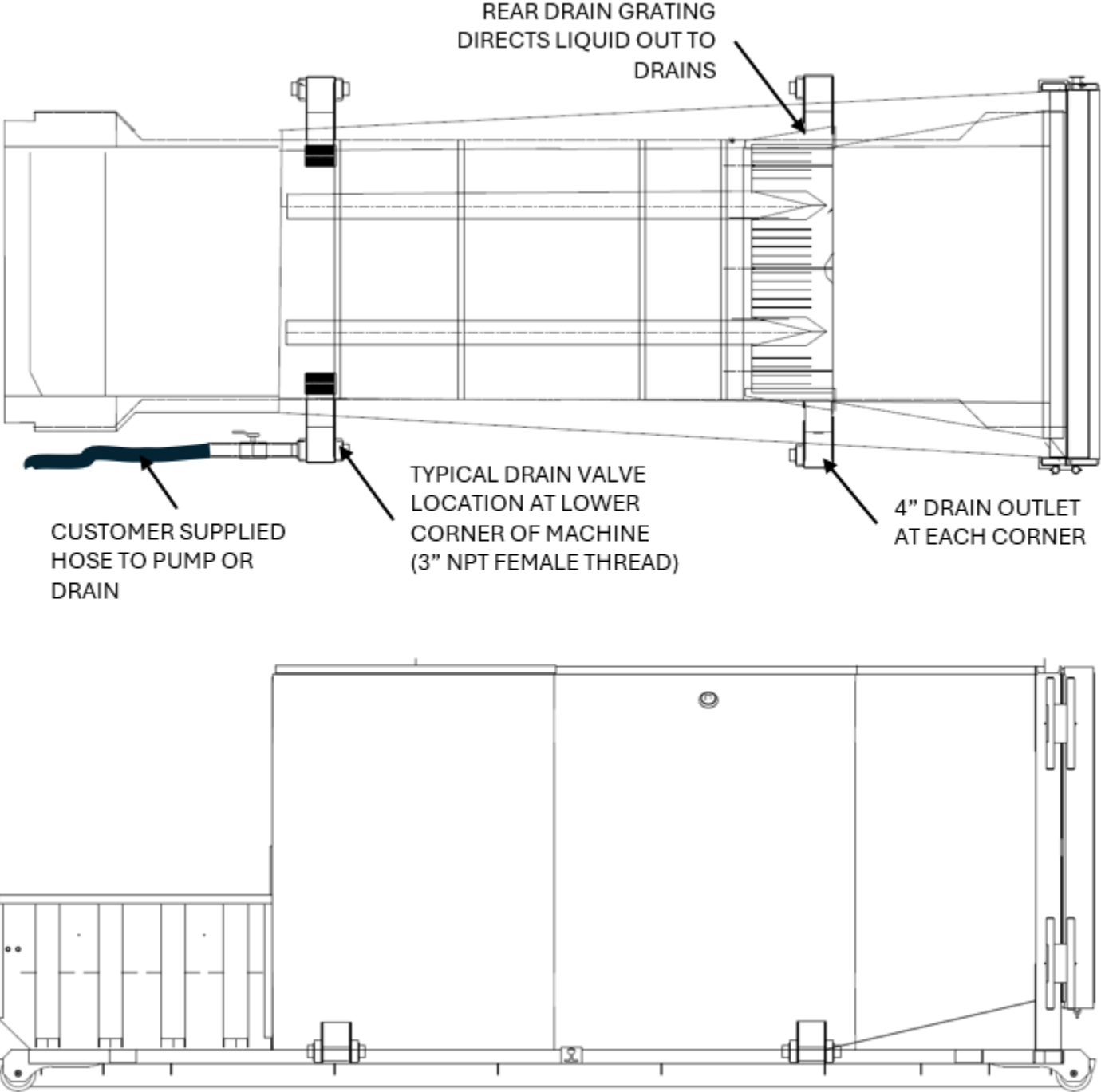

RamJet Self-Contained Compactor Container

Hauler Information

INTEGRAL DUMPER OPERATION

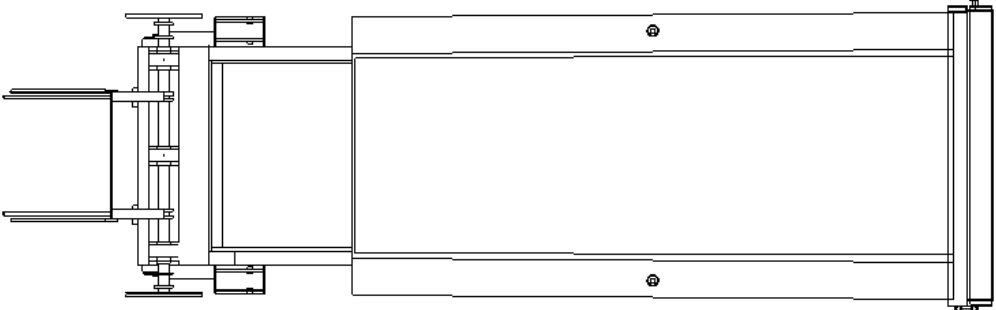

TOP VIEW
HOPPER NOT SHOWN
THIS VIEW

POSITION OF DUMPER
FOR UNIT TO BE HAULED

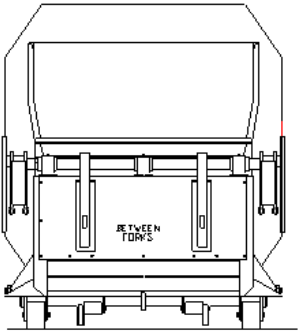

REAR VIEW

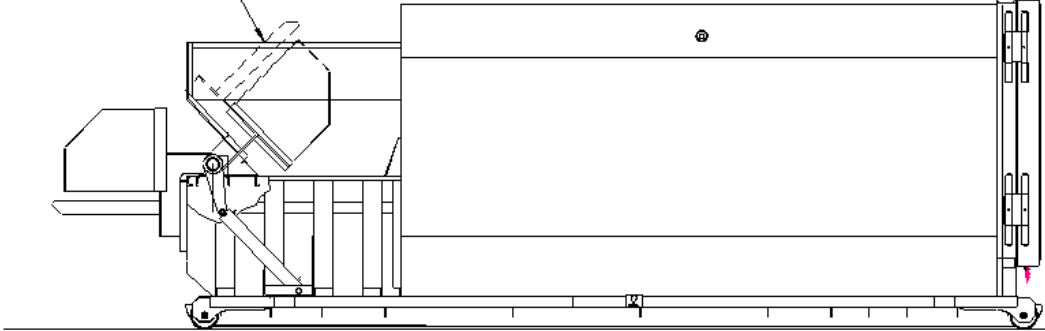

SIDE VIEW

INTENTIONALLY LEFT BLANK

SECTION 5

SERVICE

RamJet Self-Contained Compactor Container Service

52

CONTACT INFORMATION



Technical Service and Warranty:

877-258-1105

Parts:

800-528-5308

For parts visit our eCommerce Marketplace at www.mecomerchant.com.

If you do not have a user name and password, contact our Parts Department and they will assist with your registration.

Normal Business Hours:

Monday-Friday 8:00am - 5:00pm

(Central Standard Time)

RamJet Self-Contained Compactor Container

Service

LOCK-OUT & TAG-OUT INSTRUCTIONS

DANGER



Before entering any part of the compactor, be sure that all sources of energy have been shut off, all potential hazards have been eliminated, and the compactor is locked-out and tagged-out in accordance with OSHA and ANSI requirements.

The specific Lock-Out and Tag-Out instructions may vary from company to company (i.e. multiple locks may be required, or other machinery may need to be locked-out and tagged-out). The following instructions are provided as minimum guidelines.

INSTRUCTIONS

1. Notify all affected employees that servicing or maintenance is required on the compactor and that the compactor must be shut down and locked out to perform the servicing or maintenance.
2. Perform a hazard assessment;
 - a. The authorized employee shall refer to the company procedure to identify the type and magnitude of the energy that the compactor utilizes, shall understand the hazards of the energy, and shall know the methods to control the energy.
3. Wear proper personal protective equipment.
4. If compactor is operating, it must be shut down by the normal stopping procedure. If the ram is pressing against a load, move the ram rearward before shutting the compactor down.
5. De-activate the energy isolating device(s) so that compactor is isolated from the energy source(s).
 - a. Shut down all power sources.
 - b. Move the main disconnect lever to the OFF position.
6. Lockout the energy isolating device(s) with assigned individual lock(s).
 - a. Padlock the disconnect lever with a keyed padlock and take the key with you.
 - b. Along with the padlock, place an appropriate, highly visible, warning tag on the disconnect lever. The tag should provide a warning such as:
 - “Danger: Do not operate equipment. Person working on equipment.” or
 - “Warning: Do not energize without the permission of _____.”
 - c. Place operating components in such a position so as not to be subject to possible free fall and/or install additional blocking devices to prevent this potential for any raised or elevated component.
7. Stored hydraulic energy must be removed from the compactor hydraulic circuit for complete Lock-Out and Tag-Out. Make sure that this energy has been relieved by manually depressing the solenoid valve pin located in the center of each coil end of the directional control valve.
8. After locking and tagging the compactor, ensure that the compactor is disconnected from the energy source by first checking that no personnel are exposed, then verify the isolation of the equipment by operating the push button or other normal operating control(s) or by testing to make certain the equipment will not operate. Try to start and operate the compactor (as outlined in the Operating Instructions) to make sure the Lock-Out and Tag-Out is effective. If the Lock-Out and Tag-Out is effective, remove the key from the key switch and take it with you.
9. Before entering compactor perform hazard assessment for confined space requirements (hazardous fumes, dust, toxic material, or other hazards) per the OSHA confined space standard.
10. The compactor is now locked out.

RamJet Self-Contained Compactor Container

Service

LOCK-OUT & TAG-OUT INSTRUCTIONS (CONTINUED)

RESTORING SERVICE

When the servicing or maintenance is completed and the compactor is ready to return to normal operating condition, the following steps shall be taken:

1. Check the compactor and the immediate area around the compactor to ensure that nonessential items have been removed and that the compactor components, guards and covers are operationally intact.
2. Check the work area to ensure that all employees have been safely positioned or removed from any hazardous area.
3. Verify that the controls are in neutral.
4. Remove the lockout devices and re-energize the compactor.

NOTICE

The removal of some forms of blocking may require re-energizing of the compactor before safe removal.

5. Notify affected employees that the servicing or maintenance is completed and the compactor is ready for use.
6. Reassess area to determine all hazards are protected.

PERIODIC MAINTENANCE

WARNING

Ram speed accelerates as the ram retracts. Never enter any part of the self-contained compactor/container until the unit has been locked-out and tagged-out.

Monthly

- Check external hoses for chafing, rubbing, or other deterioration and damage.
- Check for any unsafe conditions in the compactor area.
- Check oil level in hydraulic reservoir. Level should be 3/4 of sight gauge (ram fully retracted).
- Clean out or wash out debris from behind compactor ram.
- Lubricate the ram guidance tracks using the grease fittings on the compactor side (For guided ram machines only), and check guide shoes for wear.
- Lubricate the pivot rod bearing blocks using the grease fittings on each block.

Three Months

- Check functional operation of controls and options (stop button, timers, lights, etc.).
- Check hydraulic cylinder, internal hoses, and connections for leakage; check hoses for chafing and wear.
- Lubricate the container door and tailgate hinges.

Annually

- Lubricate electric motor bearings annually per the manufacturer's instructions.
- Change the hydraulic fluid in the entire system. If existing oil is reused, it should be tested by a laboratory to ensure it meets necessary specifications. Additives can be added to bring oil back to standards. Before returning oil to the tank, it should be filtered through a minimum 6 micron filter. The hydraulic tank should be cleaned inside with a nonflammable solvent and thoroughly dried before replacing the oil.

Filter Maintenance

- The hydraulic filter should be cleaned at regular yearly intervals.
- The filter may be removed from the unit by disconnecting the union on the suction side of the pump, removing the four bolts retaining the cover plate, and lifting the filter from the reservoir.
- Care should be exercised in cleaning the filter to ensure that the element is not torn. Clean the element with a soft brush and standard industrial solvent.
- Replace the filter after cleaning and tighten the union securely. Pump noise and a "crackle" sound is most often caused by air entering the pump suction line. Tightening the suction fittings will usually eliminate the problem.

RamJet Self-Contained Compactor Container

Service

PERIODIC MAINTENANCE (CONTINUED)

Monthly (RJ-250WD)

Lubricate the pivot rod bearing blocks using the grease fittings on each block.

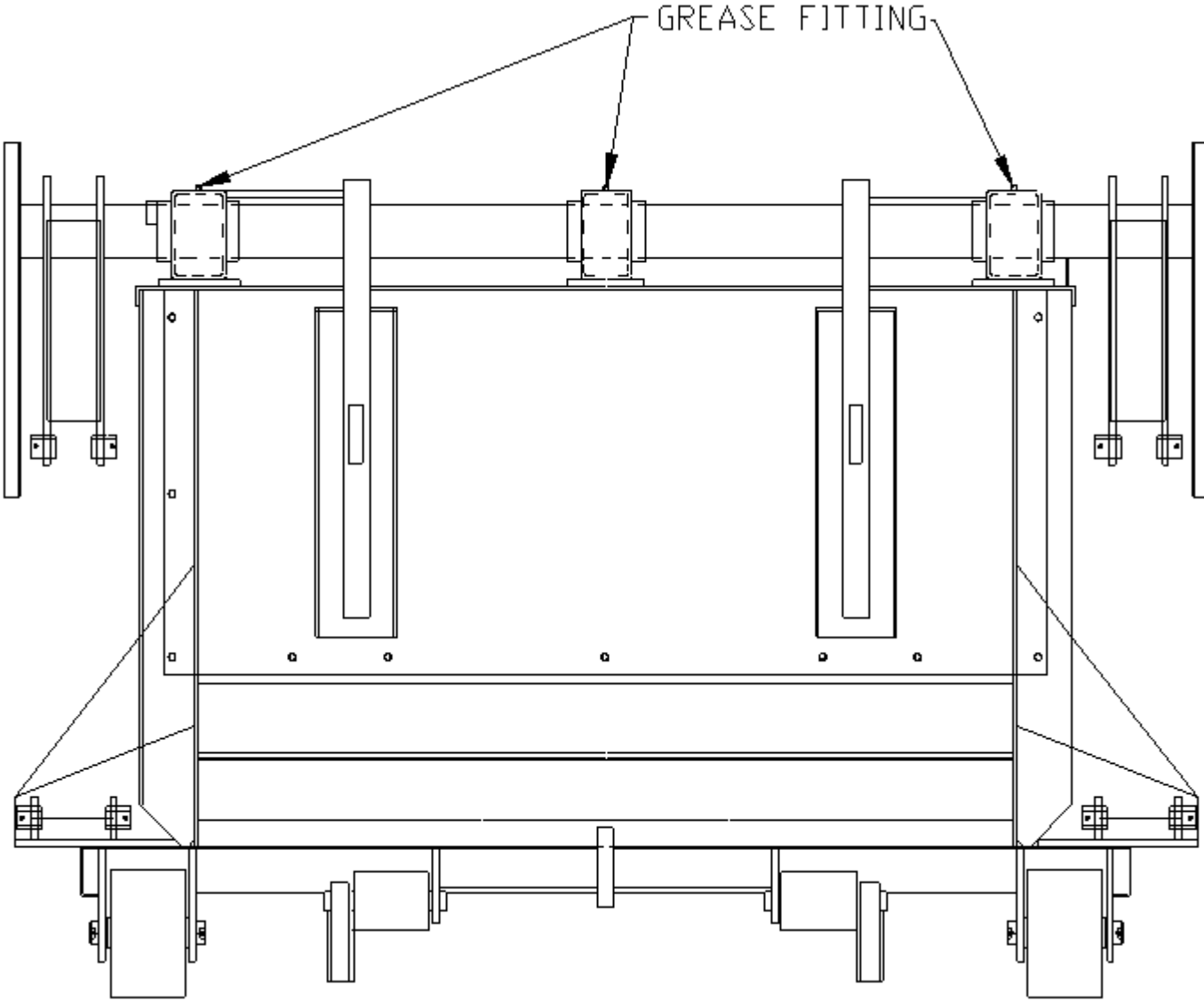

RamJet Self-Contained Compactor Container

Service

MAINTENANCE SCHEDULE FORM

Make copies of below table to record your maintenance on equipment.

MAINTENANCE SCHEDULE						
Monthly						
	CHECK UNSAFE CONDITIONS	CHECK HOSES	CHECK OIL LEVEL	CLEAN/WASH OUT DEBRIS	LUBRICATE RAM GUIDE TRACKS	CHECK GUIDES SHOES
Jan						
Feb						
Mar						
Apr						
May						
June						
July						
Aug						
Sept						
Oct						
Nov						
Dec						

MAINTENANCE SCHEDULE							
	Every 3 Months					Annually	
	CHECK FUNCTIONAL OPERATION OF CONTROLS	CHECK HYDRAULIC CYLINDER	CHECK INTERNAL HOSES	CHECK HYDRAULIC CONNECTIONS FOR LEAKS AND WEAR	LUBRICATE CONTAINER DOOR/ TAILGATE HINGES	LUBRICATE MOTOR BEARINGS	CLEAN HYDRAULIC FILTER
Jan							
Feb							
Mar							
Apr							
May							
June							
July							
Aug							
Sept							
Oct							
Nov							
Dec							

RamJet Self-Contained Compactor Container

Service

PRESSURE SETTINGS

When the hydraulic cylinders used in the RamJet Self-Contained compactor are fully extended or retracted, they bypass internally. This prevents the hydraulic system from reaching relief pressure under normal conditions. Follow the recommendations below for proper pressure setting.

1. Disconnect and lock-out power per the **Compactor Lock-Out/Tag-Out Instructions** ⁽⁷⁾.
2. Using the quick disconnects, disconnect the hydraulic hoses from the compactor.
3. Remove the 1/4" plug from the check valve and install a 0-3000 psi pressure gauge.
4. Loosen the lock nut on the relief valve and turn the adjustment screw several turns counterclockwise.
5. Remove the lock-out provisions and turn the disconnect to the ON position. Start the power unit using the **Operating Instructions** ⁽³⁾.
6. With the hoses disconnected, the power unit will build pressure. Adjust the relief pressure up by turning the relief adjustment screw clockwise. Adjust the relief valve to the desired pressure setting and tighten the lock nut. See chart below.
7. Press the EMERGENCY STOP button to stop the power unit, and relieve the stored hydraulic energy as described by the **Compactor Lock-Out/Tag-Out Instructions** ⁽⁷⁾.
8. Disconnect and lock-out power as described in Step 1.
9. Remove the pressure gauge and replace the 1/4" plug in the check valve.
10. Reconnect the hydraulic hoses, and remove the lock-out provisions.

Pressure Settings for Standard Units							
MODEL	HP	GPM	RELIEF VALVE SETTING	RESIVOIR CAPACITY	CYLINDER BORE	CYLINDER ROD	CYLINDER STROKE
RJ-88SC	5	6	1700	15	4	2 1/2	25
RJ-100SC	10	10	1850	20	5	2 1/2	42
RJ-250SC	10	10	1850	20	4	2 1/2	31 5/8
RJ-250SC Ultra	10	10	1850	20	4	2 1/2	31 5/8
RJ-SC ²	10	13	1650	20	4	2 1/2	47



RamJet Self-Contained Compactor Container

Service

PRESSURE SETTINGS (CONTINUED)

Pressure Settings with Integral Dumper

When the hydraulic cylinders used in the RamJet Self-Contained compactor are fully extended or retracted, they bypass internally. This makes it impossible for the hydraulic system to reach relief pressure. Follow the recommendations below for proper pressure setting.

1. Disconnect and lock-out power per the procedure on the **Compactor Lock-Out/Tag-Out Instructions** .
2. Using the quick disconnects, disconnect the hydraulic hoses from the compactor.
3. Remove the 1/4" plug from the check valve and install a 0-3000 psi pressure gauge.
4. Loosen the lock nut on the relief valve and turn the adjustment screw several turns counterclockwise.
5. Remove the lock-out provisions and turn the disconnect to the ON position. Start the power unit using the OPERATING INSTRUCTIONS  on page..
6. With the hoses disconnected, the power unit will build pressure. Adjust the relief pressure up by turning the relief adjustment screw clockwise. Adjust the relief valve to the desired pressure setting and tighten the lock nut. See chart below.
7. Press the EMERGENCY STOP button to stop the power unit, and relieve the stored hydraulic energy as described on page 16.
8. Disconnect and lock-out power as described in Step 1.
9. Remove the pressure gauge and replace the 1/4" plug in the check valve.
10. Reconnect the hydraulic hoses, and remove the lock-out provisions.

Pressure Settings for Units with Container Full Package (if equipped)									
MODEL	HP	GPM	ADVANCED WARNING SETTING	CONTAINER FULL SETTING	RELIEF VALVE SETTING	RESERVOIR CAPACITY	CYLINDER BORE	CYLINDER ROD	CYLINDER STROKE
RJ-88SC	5	6	1500	1700	2000	15	4	2 1/2	25
RJ-100SC	10	10	1650	1850	2300	20	5	2 1/2	42
RJ-250SC	10	10	1650	1850	2300	20	4	2 1/2	31 5/8
RJ-250SC Ultra	10	10	1650	1850	2300	20	4	2 1/2	31 5/8
RJ-SC ²	10	13	1450	1650	2000	20	4	2 1/2	47

RamJet Self-Contained Compactor Container

Service

PRESSURE GAUGE READINGS FOR COMPACTORS

COMPACTOR MODEL	ADVANCE WARNING PRESSURE	CONTAINER FULL PRESSURE
RJ - 30	1000 PSI	1200 PSI
RJ - 1835M (3HP)	1450 PSI	1650 PSI
RJ - 1835M (5HP)	1450 PSI	1650 PSI
RJ - 160	1650 PSI	1850 PSI
RJ - 225	1450 PSI	1650 PSI
RJ - 225U	1450 PSI	1650 PSI
RJ - 225HD	1900 PSI	2100 PSI
RJ - 275HD	1450 PSI	1650 PSI
RJ - 275XHD	1900 PSI	2100 PSI
RJ - 325	1450 PSI	1650 PSI
RJ - 325HD	1450 PSI	1650 PSI
RJ - 400U	1450 PSI	1650 PSI
RJ - 450	1500 PSI	1700 PSI
RJ - 500	1500 PSI	1700 PSI
RJ - 500HD	2000 PSI	2200 PSI
RJ - 550	1500 PSI	1700 PSI
RJ - 575HD	2000 PSI	2200 PSI
RJ -450HDPC	1900 PSI	2100 PSI
RJ - 575HDPC	2000 PSI	2200 PSI
MPT	1500 PSI	1700 PSI
RJ -88SC (ALL MODELS)	1500 PSI	1700 PSI
RJ - 100SC (ALL MODELS)	1550 PSI	1850 PSI
RJ - 250SC (ALL MODELS)	1550 PSI	1850 PSI
RJ-SC2	1450 PSI	1650 PSI
TC-HD (ALL MODELS)	1550 PSI	1850 PSI
TC-HDHF (ALL MODELS)	1950 PSI	2150 PSI
M - 100 (PC)	1300 PSI	1500 PSI
M - 450X 20-18	2100 PSI	2300 PSI
M - 450X 20-50	2100 PSI	2300 PSI

RamJet Self-Contained Compactor Container

Service

PRESSURE GAUGE READINGS FOR COMPACTORS (CONTINUED)

M - 600X 20-18	2000 PSI	2200 PSI
M - 600X 20-50	2000 PSI	2200 PSI
M - 600X 30-75	2300 PSI	2500 PSI
M - 800XW 20-18	2100 PSI	2300 PSI
M - 800XW 20-50	2100 PSI	2300 PSI
M - 800XW 30-75	2300 PSI	2300 PSI
M - 1050XW 30-75	2000 PSI	2200 PSI
M - 1050XW 50-100	2000 PSI	2200 PSI
M - 1050XW 50-125	2300 PSI	2500 PSI
M - 1475XW 30-75	2000 PSI	2200 PSI
M - 1475XW 50-100	2000 PSI	2200 PSI
M - 1475XW 50-125	2300 PSI	2500 PSI

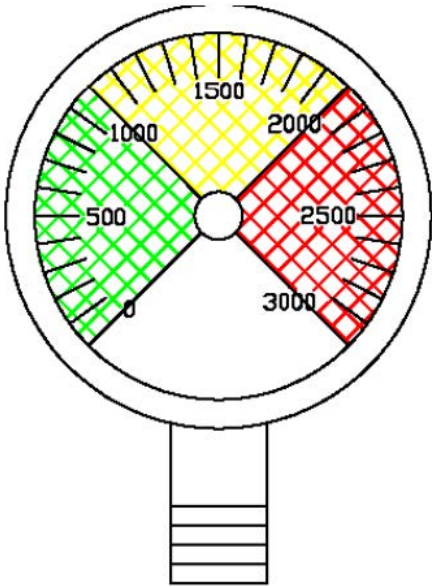
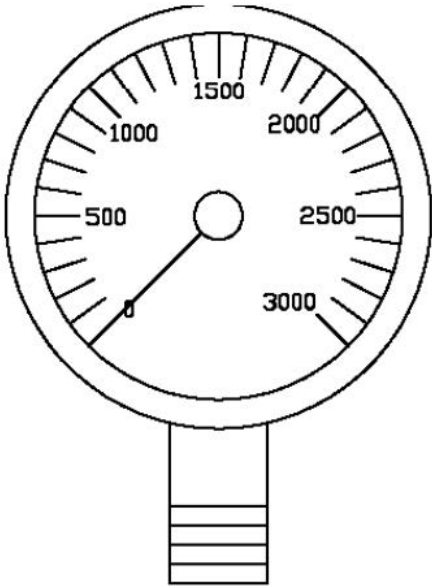

RamJet Self-Contained Compactor Container

Service

PRINCIPLES OF OPERATION

Standard System Operating Characteristics, 5 HP & 10 HP

The system uses special cylinders to move the ram and two timers to control the operation of the ram. When the hydraulic cylinders used in the self-contained compactors are fully extended or retracted, they bypass internally. This prevents the hydraulic system from reaching relief pressure under normal conditions. The sequence of operation for this system is as follows:

Upon startup, a contact is made that energizes the motor starter, starting the electric motor and at the same time energizing T1 timer coil. When T1 is energized, the valve solenoid shifts the valve so that the hydraulic oil is directed to extend the cylinder which extends the ram. When T1 timer times out, the contacts reverse causing T2 timer to energize and the solenoid to shift the valve into the reverse position. In this position, the valve directs the hydraulic oil into the front end of the cylinder causing the cylinder to retract, therefore causing the ram to retract. When T2 timer times out, the motor starter contact is opened and the motor starter/power unit shuts down.

Cylinder Removal Instructions

1. Disconnect and lock-out power per the **Compactor Lock-Out/Tag-Out Instructions** .
2. Remove access covers from compactor.
3. Remove hoses (4 for RJ-88SC & RJ-250SC, RJ-SC², 2 for RJ-100SC & RJ-250SC Ultra).
4. Remove cylinder pins.
5. Remove cylinders (2 for RJ-88SC, RJ-250SC, RJ-SC², & RJ-250SC Ultra, 1 for RJ-100SC).
6. To install the cylinders, reverse the above steps.

RamJet Self-Contained Compactor Container

Service

FUSES AND CIRCUIT BREAKERS					
Three Phase					
MOTOR SIZE	VAC	FULL LOAD AMP	DUAL ELEMENT FUSE MAX.SIZE	CIRCUIT BREAKER MAX.SIZE	SERVICE DISCONNECT AMP.
3 HP	208	8.5	15	20	30
	230	8.2	15	20	30
	460	4.1	10	15	30
	575	3.3	6	15	30
5 HP	208	13.1	30	40	30
	230	11.5	25	40	30
	460	5.7	15	20	30
	575	4.8	10	15	30
10 HP	208	27.5	50	80	60
	230	25.6	50	70	60
	460	12.8	25	35	30
	575	11.4	20	30	30
15 HP	208	47.3	60	90	60
	230	45.0	60	90	60
	460	22.5	30	40	30
	575	18.3	30	40	30
20 HP	208	51.0	100	125	100
	220		45	60	60
	230	48.0	90	125	100
	460	24.0	45	60	60
	575	19.1	35	50	60
30 HP	208	81.0	150	225	200
	230	76.0	150	200	200
	460	38.0	70	100	100
	575	28.6	60	80	60
Single Phase					
3/4 HP	120	8.2	20	20	30
	230	4.1	10	15	30
3 HP	208	15.5	30	45	30
	230	14.0	25	40	30
5 HP	208	22.0	50	80	60
	230	20.8	45	70	60
10 HP	208	43.0	100	125	100
	230	39.0	90	125	100

RamJet Self-Contained Compactor Container

Service

WIRE SIZES				
Three Phase		THW Copper 75°C (165°F)		
MOTOR SIZE	VOLTAGE	LENGTH		
		TO 100'	TO 200'	TO 300'
3 HP	208	10	8	6
	230	12	10	8
	460	12	12	12
	575	12	12	12
5 HP	208	10	6	4
	230	10	8	6
	460	12	12	10
	575	12	12	12
10 HP	208	6	4	2
	230	8	4	3
	460	12	10	8
	575	12	12	10
15 HP	208	4	2	1
	230	6	3	2
	460	10	8	6
	575	12	10	8
20 HP	208	4	1	1/0
	230	4	2	1
	460	10	8	6
	575	10	10	8
30 HP	208	2	0	3/0
	230	2	1	2/0
	460	6	6	4
	575	8	8	6
Single Phase				
3/4 HP	120	12	8	6
	230	12	12	10
3 HP	208	8	6	4
	230	8	6	4
5 HP	208	8	6	4
	230	8	6	4
10 HP	208	4	1	1/0
	230	4	2	1/0

RamJet Self-Contained Compactor Container

Service

DISCONNECTS FOR RJ-250WD INTEGRAL DUMPER

POWER UNIT TYPE	VOLTAGE	PHASE	HP	MAIN MOTOR kW	NAME PLATE FLA	SERVICE DISCONNECT AMP.
10 HP 3PH 7.5 kW	220	3	10	7.5	27	60
	380	3	10	7.5	15.6	60
	415	3	10	7.5	14.3	30
	440	3	10	7.5	13.5	30

WIRE SIZES

POWER UNIT TYPE	VOLTAGE	DUAL ELEMENT FUSE SIZE	CIRCUIT BREAKER	WIRE SIZE 75 DEG C 100' AWG (mm sq.)	WIRE SIZE 75 DEG C 200' AWG (mm sq.)	WIRE SIZE 75 DEG C 300' AWG (mm sq.)
10 HP 3PH 7.5 kW	220	45	60	8(10)	4(25)	3(35)
	380	30	40	12(4)	10(6)	8(10)
	415	30	40	12(4)	10(6)	8(10)
	440	25	30	12(4)	10(6)	8(10)

RamJet Self-Contained Compactor Container

Service

TAILGATE SEAL REPLACEMENT

When the tailgate seal becomes damaged or worn, replace the seal.

⚠ WARNING

For units with hydraulic tailgates, before performing any inspection or maintenance on the seal, support the raised tailgate with a crane, forklift, or other positive maintenance prop.

- When removing the old seals (top & bottom) mark the position of the seal joints.
- Pry the seal retainer up slightly to allow removal of the old seals.
- When installing the new seals, join the seals at the same position.

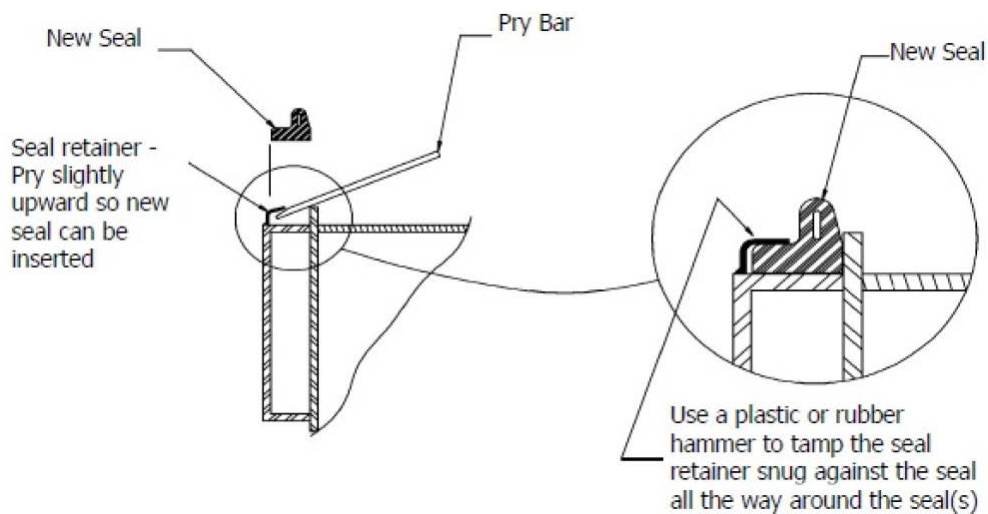
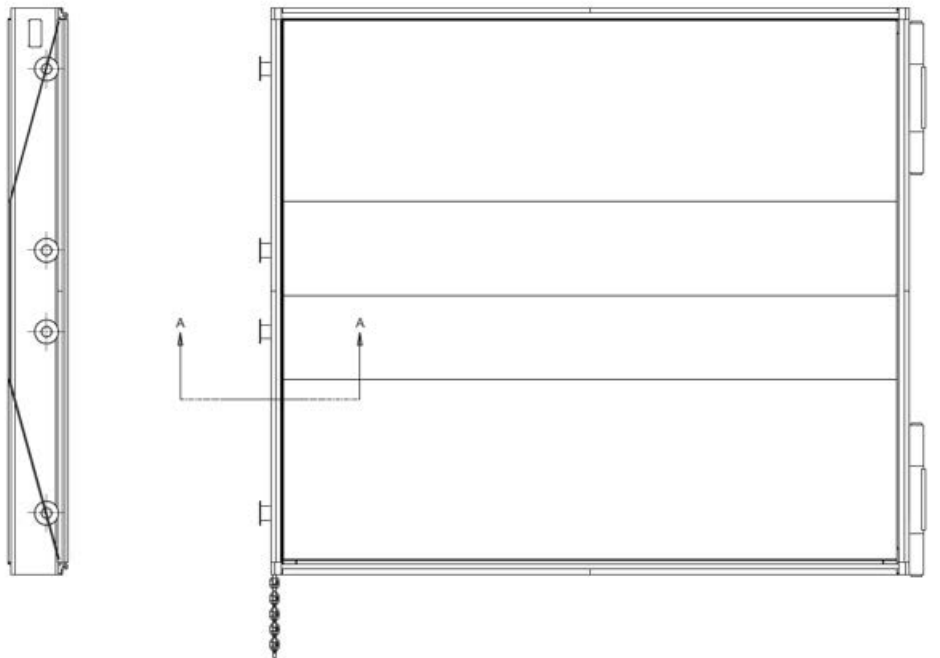

RamJet Self-Contained Compactor Container

Service

PLC MAINTENANCE - LAYOUT & DESCRIPTION

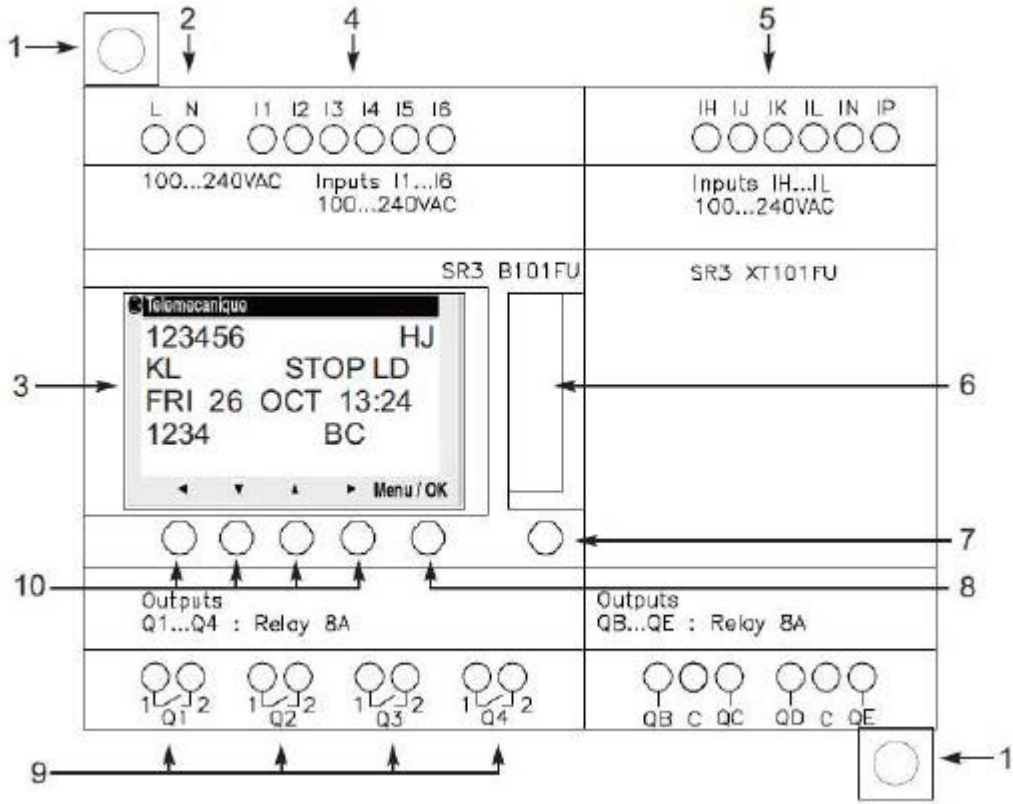

REFERENCE	DESCRIPTION
1	Retractable mounting feet
2	Screw terminal block for the power supply
3	LCD, 4 lines, 18 characters
4	Screw terminal block for inputs
5	Screw terminal block for discrete input
6	Connector for backup memory or PC connection cable
7	Shift key
8	Selection and validation key (Menu / Ok)
9	Relay output screw terminal block
10	Arrow keys

RamJet Self-Contained Compactor Container

Service

PLC MAINTENANCE - LAYOUT & DESCRIPTION (CONTINUED)

MULTICYCLE COUNTER SELECTION	
STEPS	DIRECTIONS
1	Press the Menu Button
2	Press Arrow Down Button to select PARAMETER (flashing)
3	Press Menu/Ok Button
4	Press Arrow Up Button until CC2 is flashing
5	Press Arrow Left Button until P=0001 is (flashing)
6	Press Arrow Down or Arrow Up to select cycle count
7	Press Menu/Ok Button
8	Press Menu/Ok Button with YES to Confirm Changes
9	Press the Menu Button

RAM STOP REAR OR RAM STOP FORWARD SELECTION	
STEPS	DIRECTIONS
1	Press & Hold the Arrow Left Button to Change and display the current ram stop position
Repeating this process switches the current position to ram stop forward or ram stop reverse.	

PLC MAINTENANCE - EXTEND/RETRACT TIMER ADJUSTMENT	
STEPS	DIRECTIONS
1	Press the Menu Button
2	Press the Up or Down Arrow Button until you get to PARAMETER
3	Press the Menu Button
4	Press the Up or Down Arrow Button until TT1 is flashing (Extend Timer)
5	Press the < Arrow Button
6	Press the Up or Down Arrow Button until the desired time is flashing
7	Press Menu
8	Press Menu with YES blinking
9	Repeat Steps 4-8 with TT2 (Retract Timer)
10	Press the Menu Button to return to normal operation.

TIMER SETTINGS (IN SECONDS)				
MODEL NO.	RAM STOP REAR		RAM STOP FORWARD	
	TT1	TT2	TT1	TT2
RJ-SC ²	25	17	17	25
RJ-88SC	27	17	17	27
RJ-100SC	21	16	16	21
RJ-250SC	19	13	13	19
RJ-250SC Ultra	19	13	13	19

RamJet Self-Contained Compactor Container

Service

ELECTRICAL SCHEMATIC

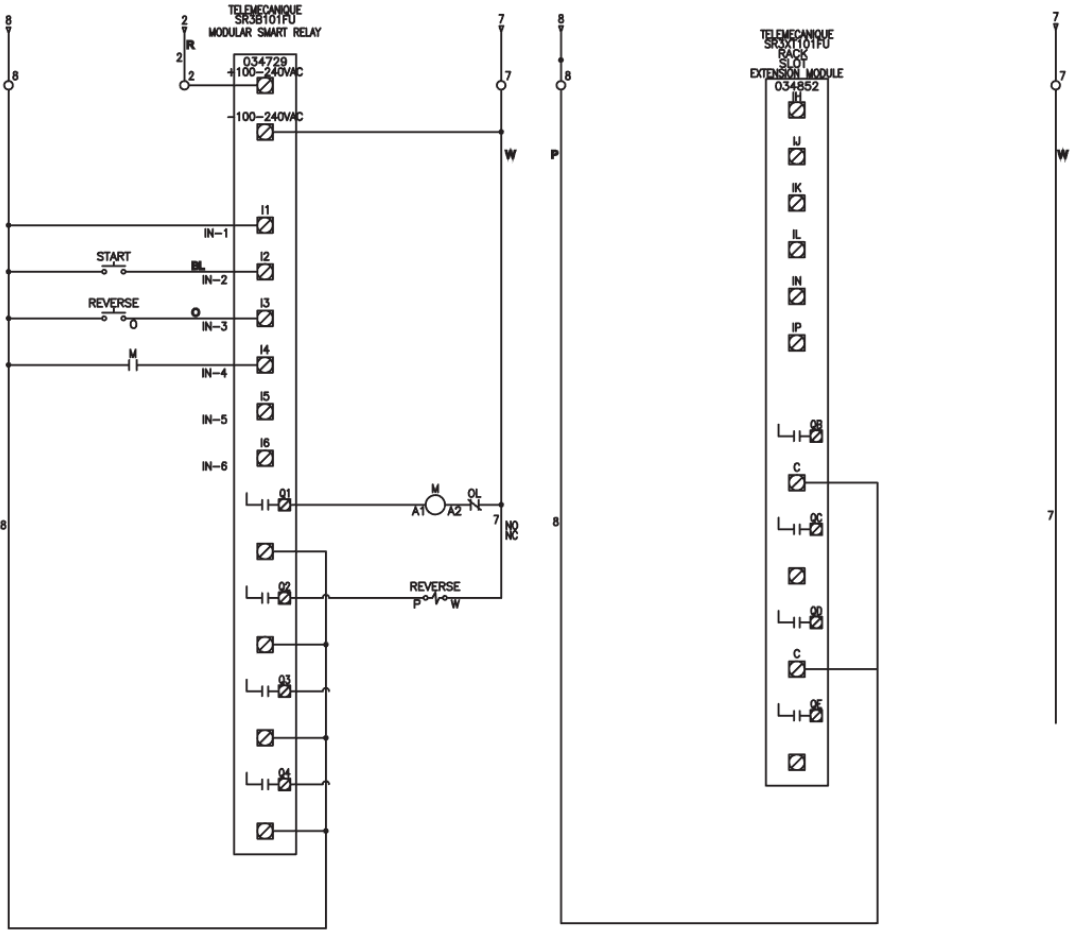
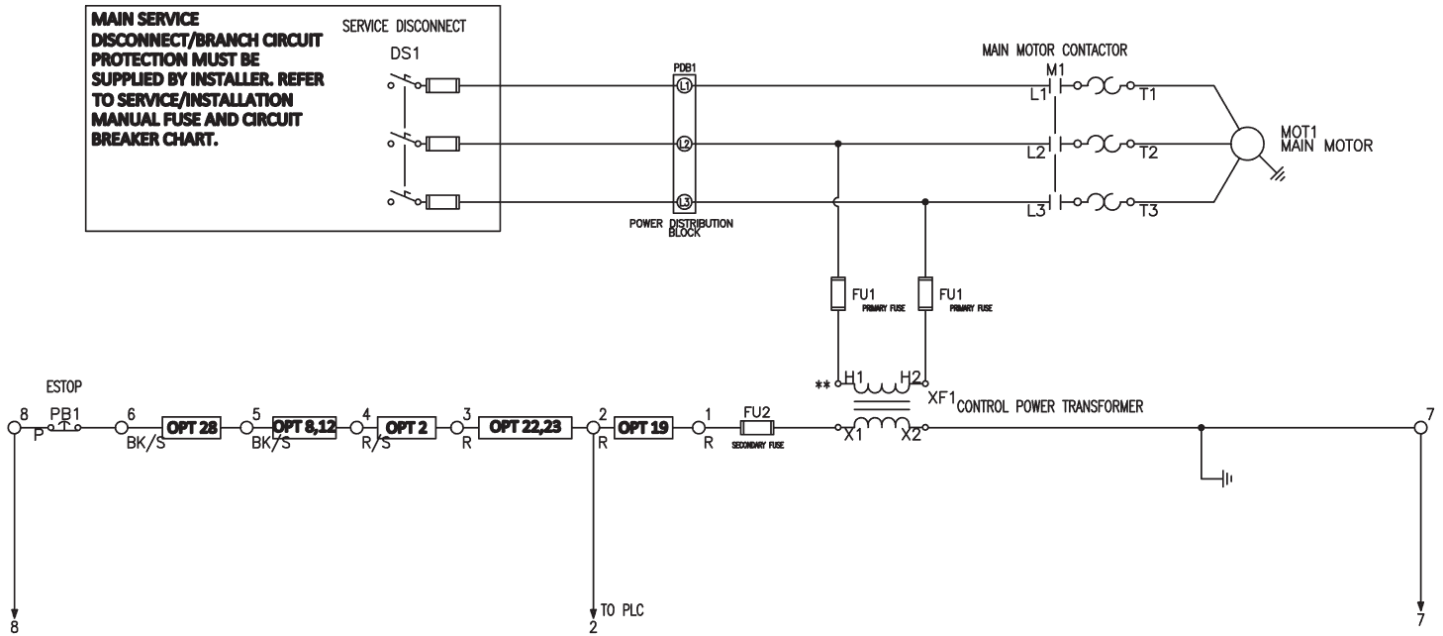

RamJet Self-Contained Compactor Container

Service

HYDRAULIC SCHEMATIC - TYPICAL (CYCON)

1. Cylinder
2. Quick Disconnect (Female)
3. Quick Disconnect (Male)
4. Valve, 4-Way
5. Relief Valve
6. Check Valve
7. Pump
8. Suction Filter
9. Hub Coupling (Not on Closed-Coupled Units)
10. Motor

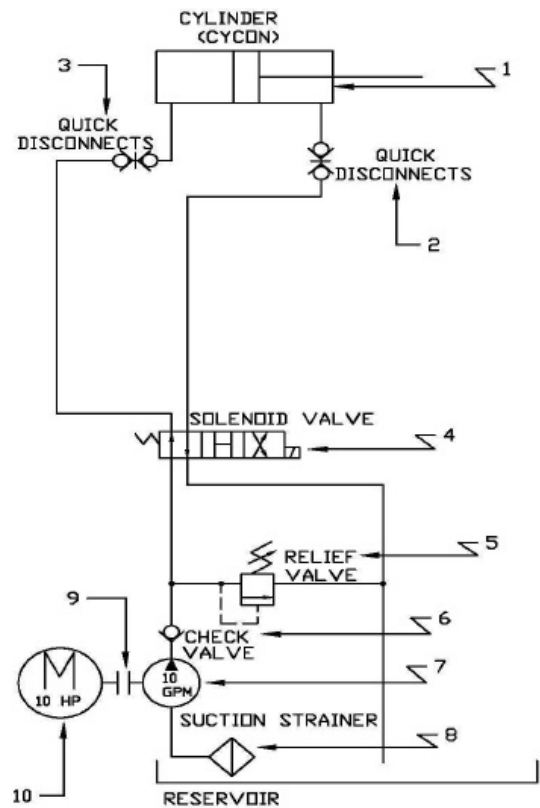

NOTICE

Single cylinder unit shown. For dual cylinder units, connect identical cylinder in parallel.

RamJet Self-Contained Compactor Container

Service

HYDRAULIC SCHEMATIC WITH INTEGRAL DUMPER

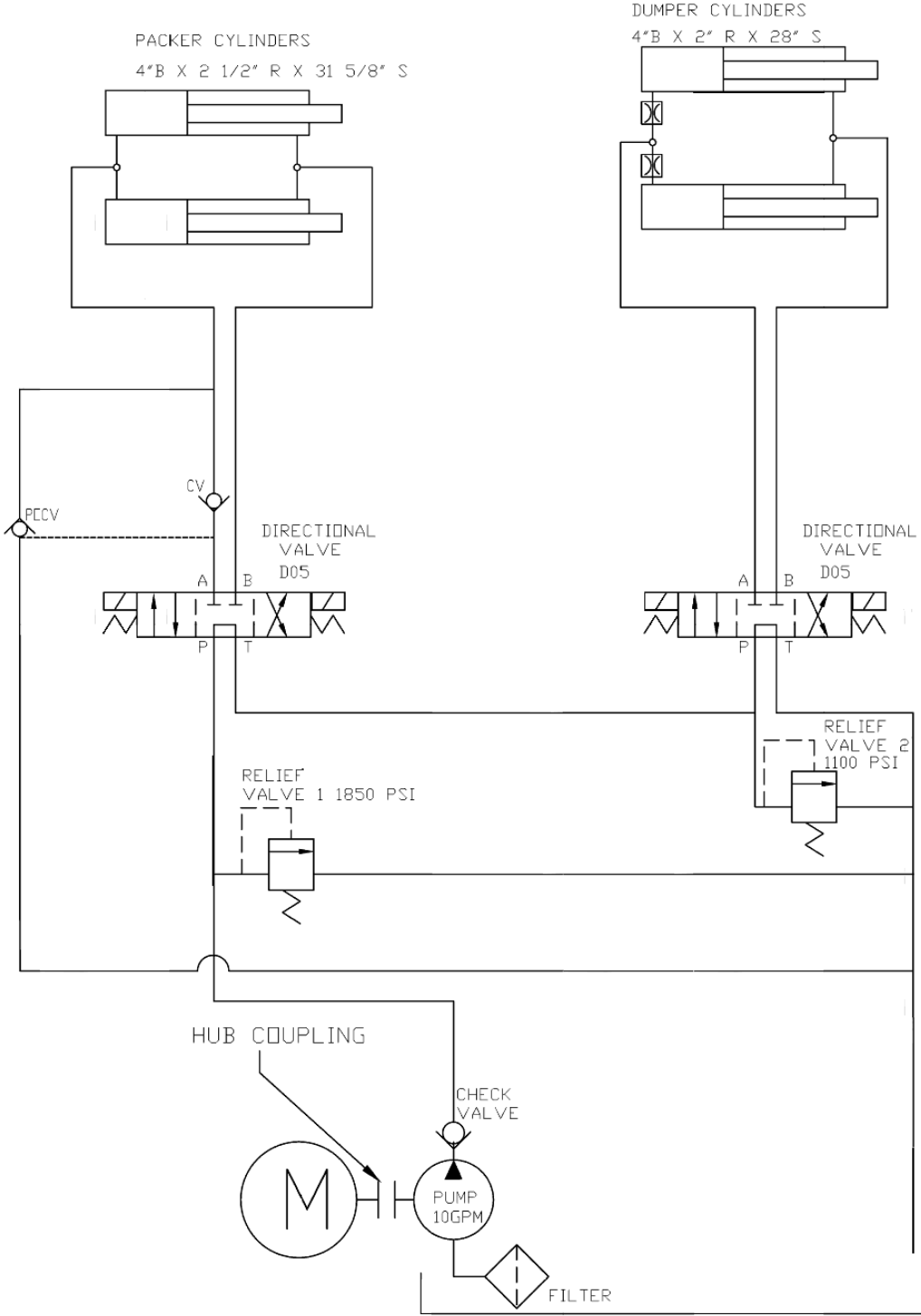

RamJet Self-Contained Compactor Container

Service

TROUBLESHOOTING CHART		
PROBLEM	CAUSE	SOLUTION
UNIT WILL NOT START	1. No electrical power to unit	1a. Turn on main disconnect. 1b. Replace fuses/reset breakers
	2. No electrical power to control circuit	2a. Check primary and secondary sides of transformer. 2b. Check for correct voltage. Check control fuses. 2c. Check stop button. 2d. Check start button to be sure contact closes when depressed.
	3. No electrical power to motor	3a. Check heater resets
UNIT WILL NOT CONTINUE RUNNING WHEN START BUTTON IS RELEASED	1. Motor starter is inoperative.	1a. Check motor starter coil & wiring.
	2. Motor starter auxiliary contacts are inoperative	2a. Check motor starter contacts and wiring
	3. Reverse Button is inoperative	3a. Check wiring
	4. Secondary contact on start button is inoperative	4a. Check contact, wired black and orange, to be sure it is operating properly 4b. Check wiring
MOTOR RUNS BUT RAM DOES NOT MOVE NORMALLY	1. Insufficient oil in reservoir	1a. Fill reservoir with oil
	2. Low relief pressure	2a. Check relief pressure (refer to PROCEDURES-HYDRAULIC PRESSURE CHECK and PRESSURE SETTINGS for correct pressure. 2b. Clean orifice in relief valve and reset pressure 2c. Check "O" rings on relief valve for damage or leakage
	3. Oil leakage in cylinder	3a. Check cylinder for bypassing 3b. Replace seal kit, inspect rod and cylinder tube for scoring/nicks 3c. Replace cylinder
	4. Defective pump	4a. Replace pump
	5. Oil leakage from hose fittings	5a. Tighten hose fittings
	6. Low voltage	6a. Check voltage
	7. Pump may be driven in the wrong direction of rotation	7a. Stop immediately to prevent seizure. Check direction of drive rotation (proper rotation direction is indicated by arrow on motor)
	8. Shaft broken, or shaft key sheared	8a. Visually inspect motor and pump shaft and hub couplings for damage. Replace if necessary.
	9. Intake pipe from reservoir blocked, or oil viscosity too heavy to prime	9a. Drain system. Add clean fluid of proper viscosity and specifications. Filter as recommended. Check system filter for cleanliness.
	10. Intake air leaks (foam in oil or sounds like gravel in pump)	10a. Check intake connections. Tighten securely
	11. Units shift slowly	11a. Flow control valve (restrictor) clogged, remove/clean orifice.
	12. Valve response sluggish	12a. Contaminated oil-drain and flush system. 12b. Inadequate voltage, check voltage. 12c. Disassemble valve & clean

RamJet Self-Contained Compactor Container

Service

TROUBLESHOOTING CHART		
PROBLEM	CAUSE	SOLUTION
UNIT WILL NOT REVERSE	1. Solenoid valve is in-operative	1a. Check coil in solenoid valve
	2. Reverse button in-operative	2a. Check reverse button contacts
PUMP MAKES NOISE-SOUNDS LIKE GRAVEL	1. Partly clogged intake strainer or restricted intake pipe	1a. Pump must receive intake fluid freely or cavitation results. Drain system, clean intake pipe and clean or replace strainer
	2. Defective bearing	2a. Replace pump
	3. Air leak at pump intake pipe joints	3a. Tighten joints as required.
PUMP SHAFT SEAL LEAKING	1. Seal worn or damaged	1a. Replace seals or pump.
EXCESSIVE HEAT	1. Continuous running	1a. When over 140° F or hot in comparison with circuit lines, pump should be shut down immediately. Before restarting, insure that fluid cooling capacity is adequate to remove system generated heat. 1b. Install oil cooler (air or water type) 1c. Install oil temperature shut down switch 1d. Check to be sure CYCON Power Pack has not been exchanged for Pressure Shifting Power Pack.
	2. Undersized hydraulic lines	2a. Replace with larger hydraulic lines
	3. High ambient temp in relation to oil temp.	3a. Use lower viscosity oil
	4. Excessive system leakage	4a. Check system for bypassing or leaks
RAPID WEAR	1. Abrasive matter in the hydraulic oil being circulated through pump	1a. Install adequate filter or clean filter. 1b. Replace oil more often and clean tank
	2. Viscosity of oil too low at working conditions	2a. Replace oil with factory recommended oil.
	3. Pressure too high	3a. Reduce pump pressures to factory specifications.
	4. Air recirculation causing pump noise	4a. Tighten all fittings.
ERRATIC OPERATION	1. Valve sticking or binding	1a. Disassemble & clean as necessary
	2. Viscosity of oil too high	2a. Change oil to factory recommended viscosity
	3. Air in system	3a. Check for leaks, tighten fittings
	4. Low oil	4a. Fill reservoir with oil
	5. Low voltage	5a. Check primary & secondary sides of transformer for correct voltage
OVERLOADS TRIP FREQUENTLY		1a. Check for correct voltage (incoming power.) 1b. Check fuses or breakers at disconnect 1c. Check heater elements to be sure they are tight 1d. Check wiring from starter to motor-make sure all connections are tight 1e. Check motor leads to be sure all connections are tight surges or voltage
	NOTE: Excessive overload tripping and/or motor or coil failures may occur if voltage surges or voltage drops are frequent in your area. This circumstance can be remedied by the installation of phase protectors which drop power to the motor if surges are present.	

INTENTIONALLY LEFT BLANK

SECTION 6

REPLACEMENT PARTS

RamJet Self-Contained Compactor Container

Replacement Parts

76

CONTACT INFORMATION



Technical Service and Warranty:

877-258-1105

Parts:

800-528-5308

For parts visit our eCommerce Marketplace at www.mecomerchant.com.

If you do not have a user name and password, contact our Parts Department and they will assist with your registration.

Normal Business Hours:

Monday-Friday 8:00am - 5:00pm

(Central Standard Time)

RamJet Self-Contained Compactor Container

Replacement Parts

CYLINDER REPLACEMENT PARTS

Model	Cylinder	Cylinder Seal Kit	Cylinder Pin	Pinning bushing
88-SC	04-3842	04-0301	09-3874	09-2229
100-SC	04-0310	04-0311	04-0315	N/A
250-SC	04-3791	02-6407	456894	N/A
250-HT Tailgate	04-0210	04-0211	12-1108	N/A
SC	04-3876	04-3881	Rear 464882 Front 37-0210	N/A
*Cylinder/Seal Kit/Cylinder Pins are consistent across all 250 models including 250 SC, HT, Ultra, Stream line.				

RamJet Self-Contained Compactor Container

Replacement Parts

100SC, 250SC RAM ASSEMBLY PARTS

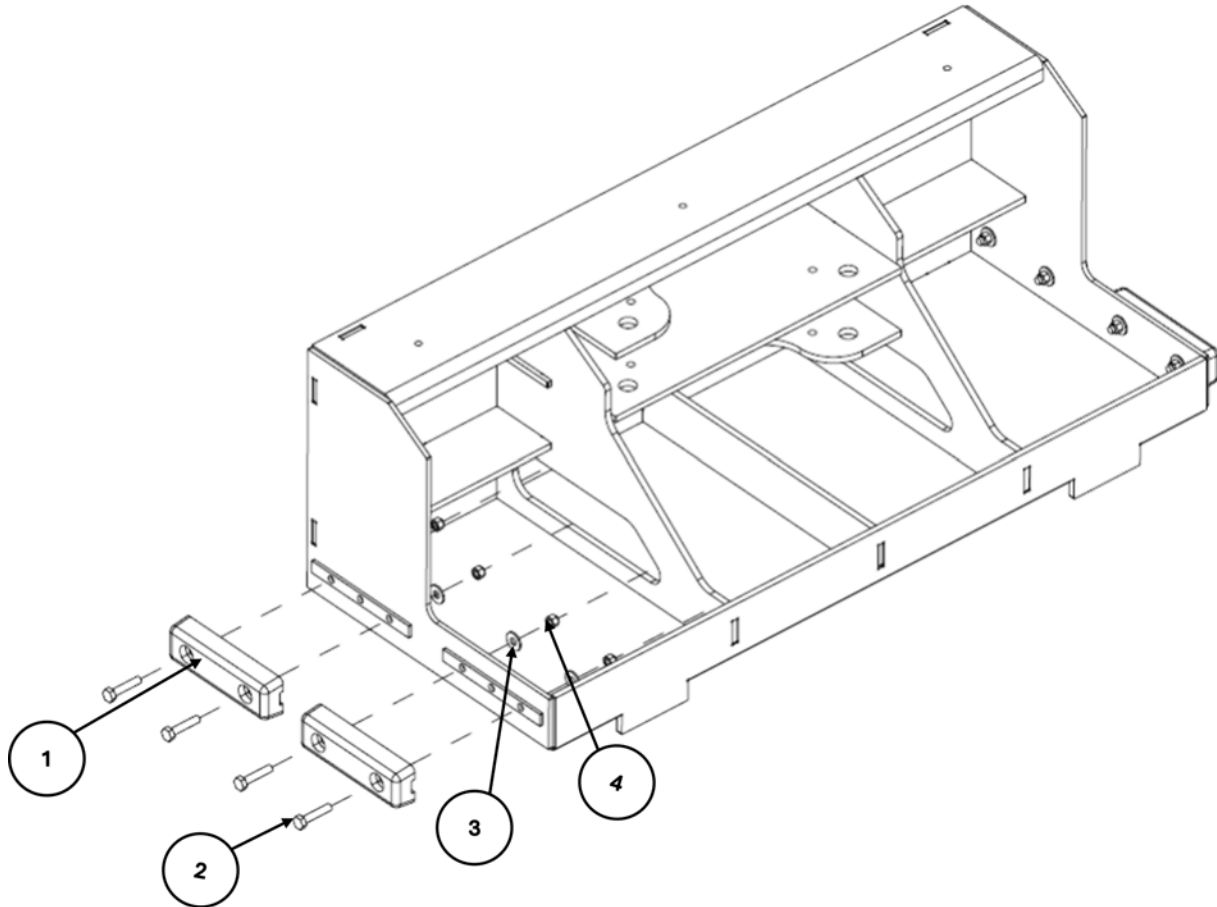

MISCELLANEOUS HARDWARE PART LIST – 100SC, 250SC RAM ASSY

ITEM	PART NUMBER	DESCRIPTION
1	06-0006	SHORT SHOE
2	05-0017	BOLT, HHCS
3	05-0052	WASHER, FLAT
4	05-0018	NUT, SELF LOCKING

RamJet Self-Contained Compactor Container

Replacement Parts

UNDERSTRUCTURE AND LATCH ASSEMBLY PARTS

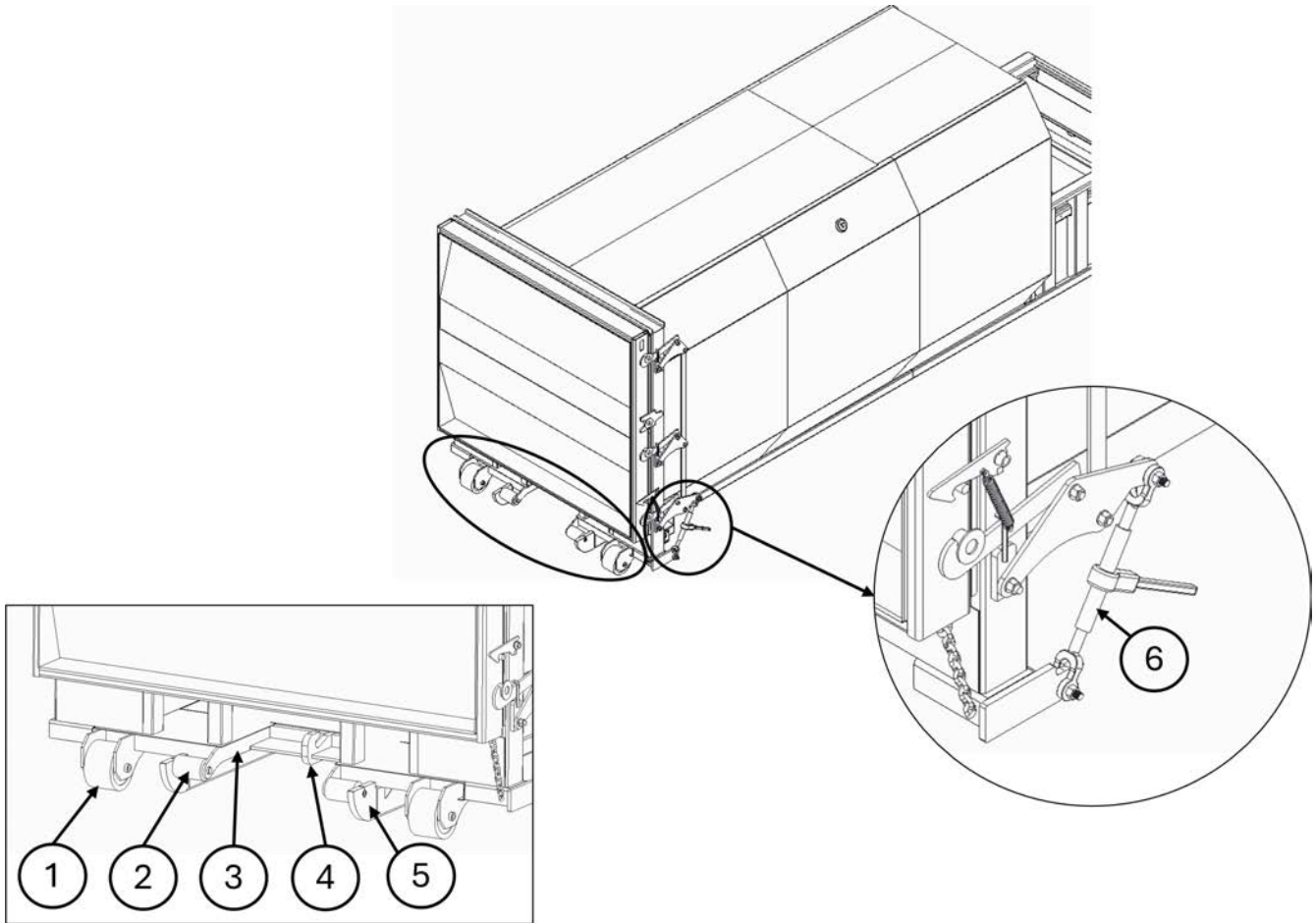

UNDERSTRUCTURE PART LIST		
ITEM	PART NUMBER	DESCRIPTION
1	06-2880	GROUND ROLLER
	06-3372	GROUND ROLLER, RUBBER
2	06-3691	GUIDE ROLLER
3	12-2112	GUIDE ROLLER MOUNTING BRACKET
4	12-0093	HOOK
5	12-2114	BULL NOSE FOR SC
LATCH		
6	447966	RATCHET ASSEMBLY HARDWARE KIT
7	05-4144	SPRING BRACKET
8	05-6178	SPRING

RamJet Self-Contained Compactor Container

Replacement Parts

TAILGATE ASSEMBLY PARTS

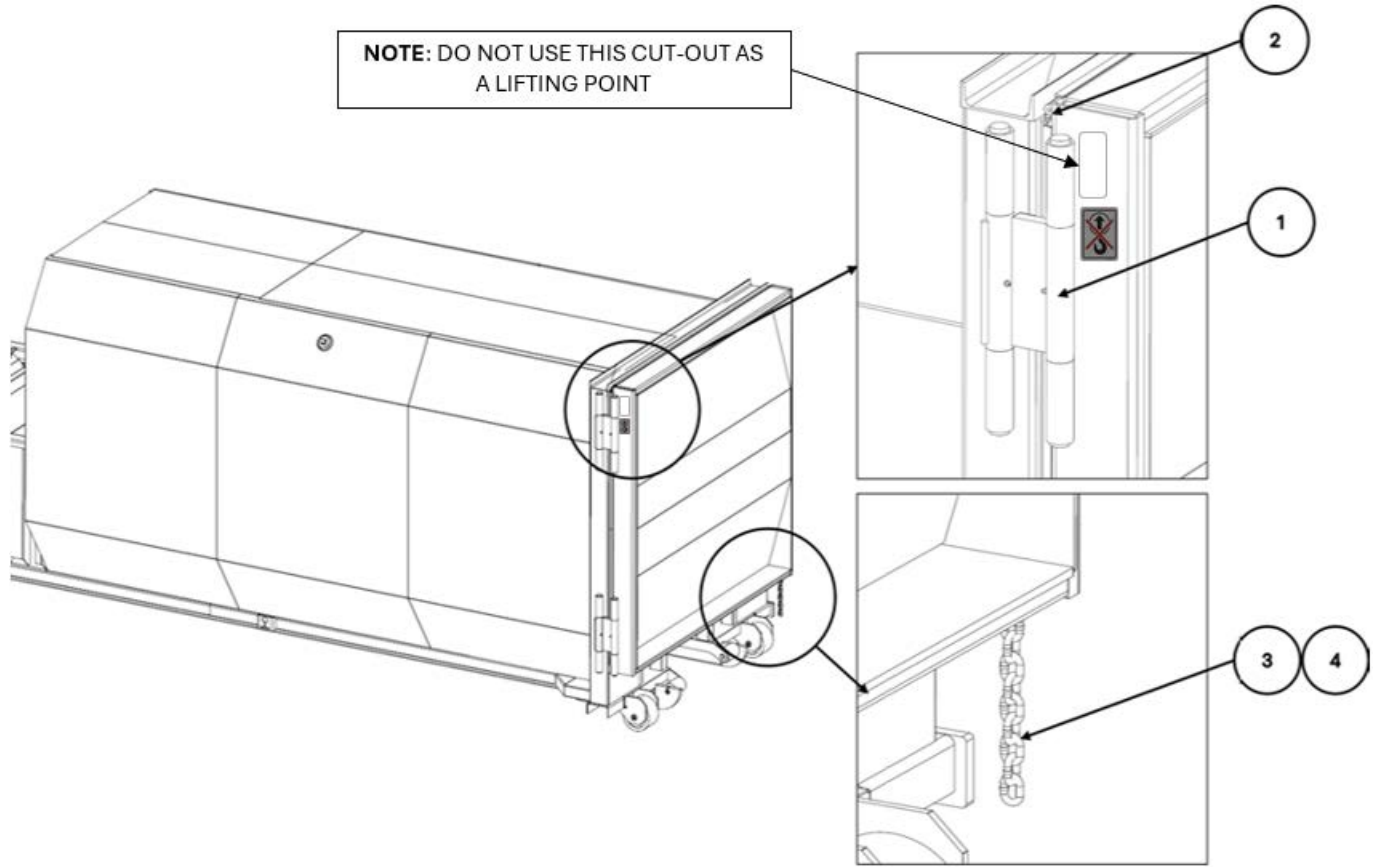

TAILGATE PART LIST		
ITEM	PART NUMBER	DESCRIPTION
1	435622	DOUBLE HINGE F/SC TAILGATE
2	05-0247	P SEAL
3	05-0264	CHAIN
4	05-2845	UBOLT

RamJet Self-Contained Compactor Container

Replacement Parts

TOP COVER PARTS

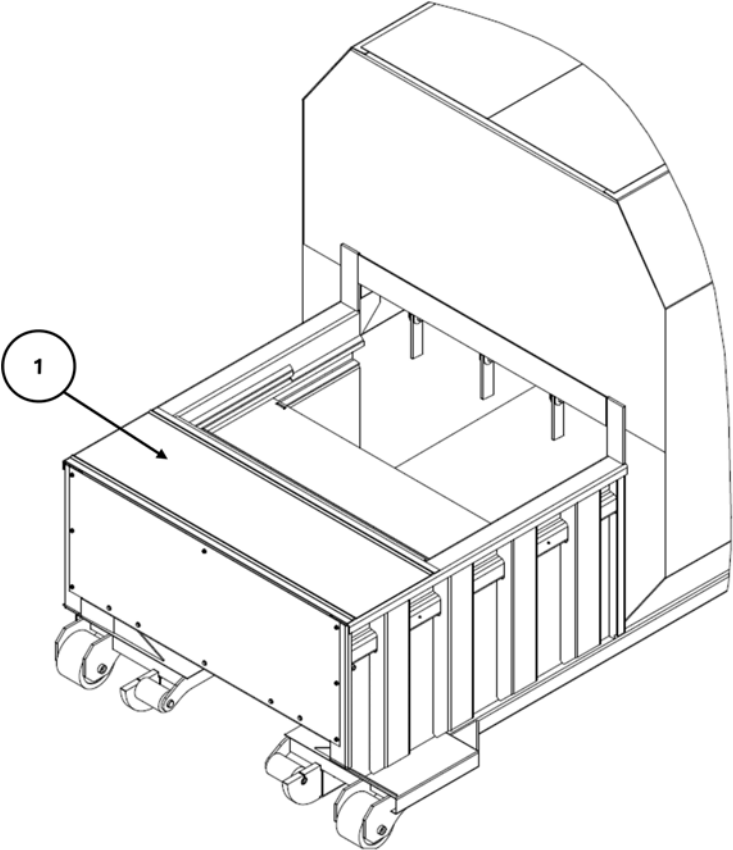

TOP COVER (250 SC) PART LIST		
ITEM	PART NUMBER	DESCRIPTION
1	09-2263	TOP COVER
TOP COVER (100 SC) PART LIST		
1	09-1604	TOP COVER
1	09-1606	TOP COVER

RamJet Self-Contained Compactor Container

Replacement Parts

HOPPER ASSEMBLY PARTS

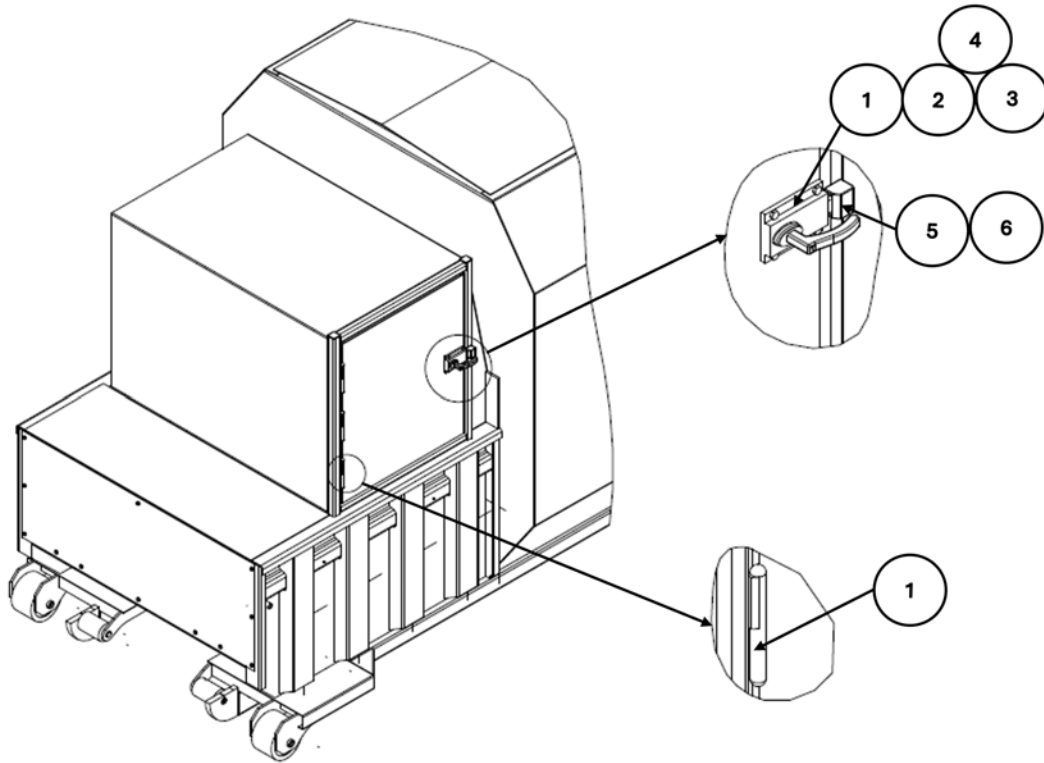

TAILGATE PART LIST SLAM LATCH

ITEM	PART NUMBER	DESCRIPTION
1	05-4991	SLAM LATCH
2	05-0549	BOLT X 4 Qty
3	05-0198	WASHER X 4 Qty
4	05-0105	NUT X 4 Qty
5	05-5027	STRIKER

AUTO LATCH

1	05-5499	AUTO LATCH
2	05-0549	BOLT X 4 Qty
3	05-0198	WASHER X 4 Qty
4	05-0105	NUT X 4 Qty
5	05-0527	STRIKER
6	09-4989	SHIM PLATE

HINGE

1	05-4989	HINGE X 3 Qty
---	---------	---------------

RamJet Self-Contained Compactor Container

Replacement Parts

HOPPER INTERLOCK PARTS

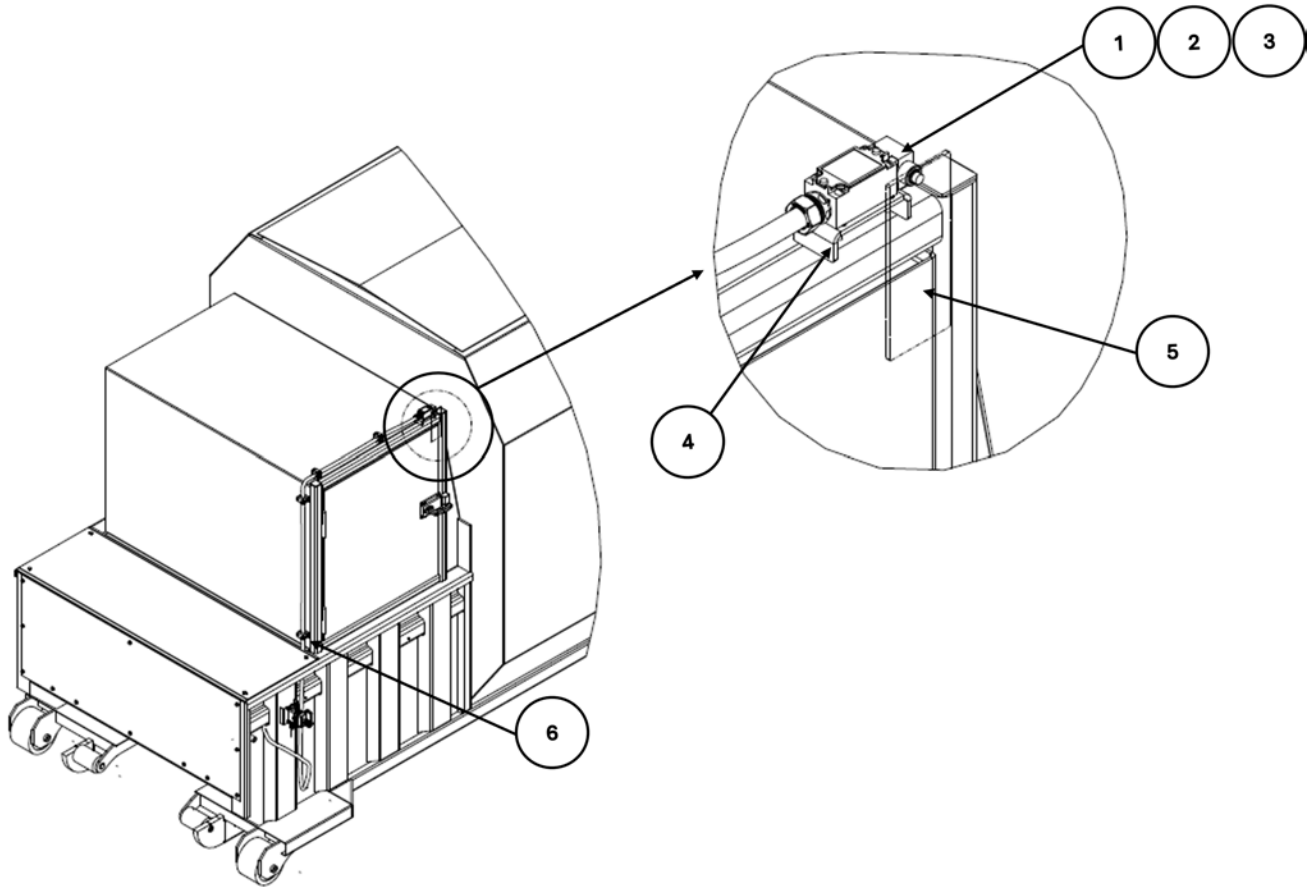

INTERLOCK KIT PART LIST		
ITEM	PART NUMBER	DESCRIPTION
1	03-0174	PUSH BUTTON INTERLOCK
2	05-0042	BOLT X 4 Qty
3	05-0010	NUT X 4 Qty
4	38-1843	MOUNT PLATE
5	38-1844	STRIKER PLATE
6	02-0306	CLAMP

RamJet Self-Contained Compactor Container

Replacement Parts

Miscellaneous Hardware 250 SC HT

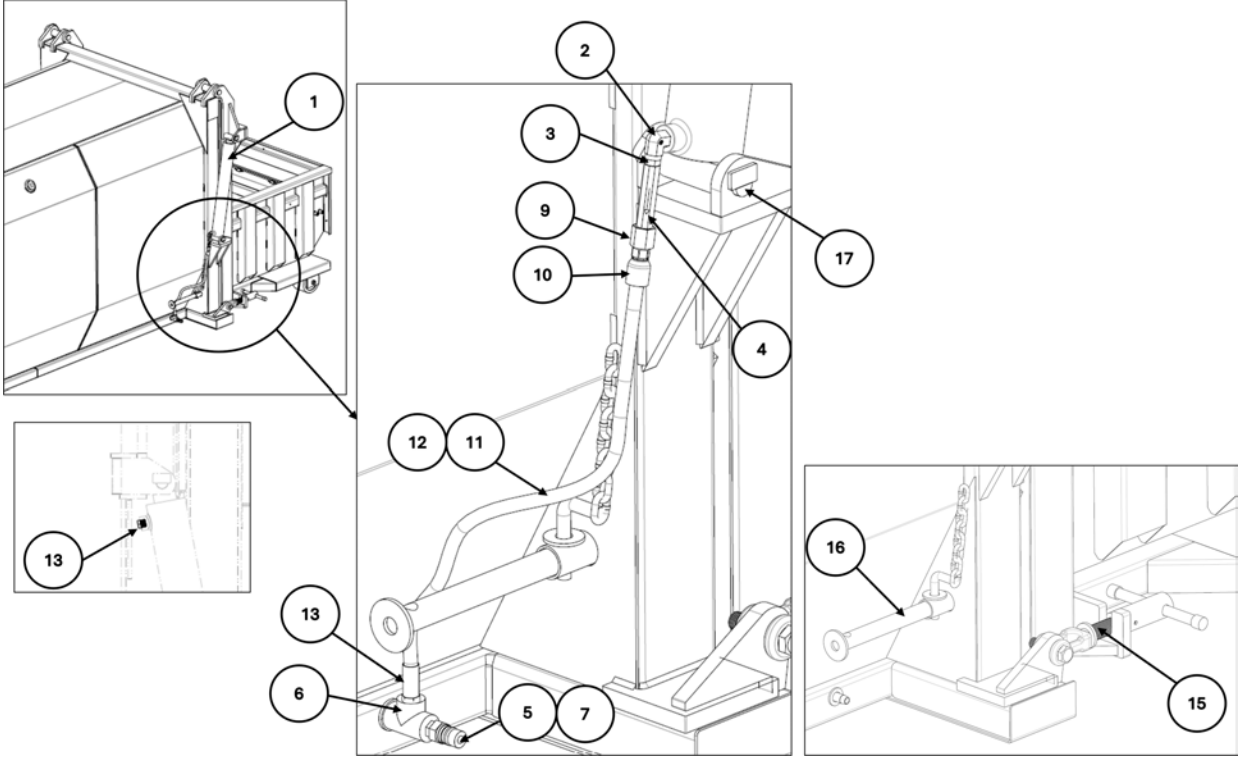

RamJet Self-Contained Compactor Container

Replacement Parts

Miscellaneous Hardware 250 SC HT (Continued)

INTERLOCK KIT PART LIST		
ITEM	PART NUMBER	DESCRIPTION
1	04-0210	CYLINDER
2	02-0113	ELL3/8 NPTF X 1/2 NPTM 90
3	02-0025	NIPPLE 1/2 NPT
4	02-0284	VALVE FLOW CONTROL
5	02-0036	NIPPLE 1/2 NPT
6	02-0035	TEE 1/2 NPTF
7	02-3055	QUICK DISCONNECT 1/2 NPTF MALE
8	02-0328	HOSE END 1/2 WB X 1/2 SW NPTM
9	02-0032	ADAPTER 3/8 NPTM X 1/2 SW NPTM
10	02-2260	HOSE END 1/2 WB X 3/8 NPTM
11	02-0330	HOSE 1/2 WB 3500PSI
12	05-0232	SPRING GUARD F/ 1/2 WIRE BRAID
13	02-0305	BREATHER FILTER PLUG TYPE 1/2
14	02-0179	PLUG 1/2 NPT
15	05-0224	SWING BOLT
	05-5635	BOLT
	05-5593	NUT
16	27-1624	PUSH ROD
17	12-1108	CYLINDER PIN

RamJet Self-Contained Compactor Container

Replacement Parts

POWER UNIT - STANDARD 5 HP

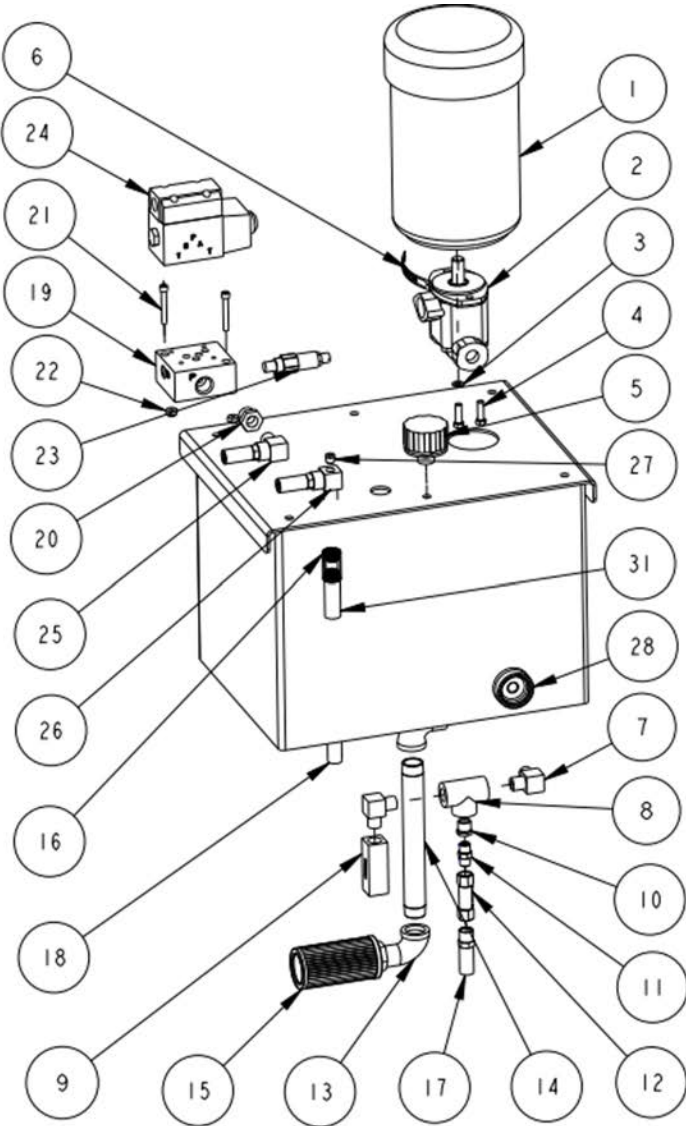
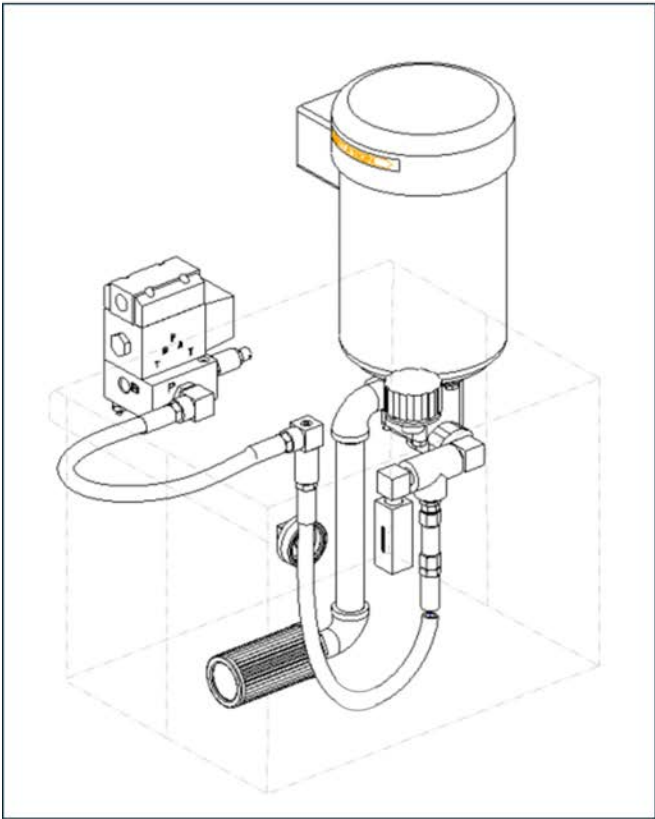

RamJet Self-Contained Compactor Container

Replacement Parts

POWER UNIT - STANDARD 5 HP - PARTS LISTS

Match reference numbers with the chart on the previous page to identify components. For replacement part ordering, call our parts department at 800-528-5308.

ITEM NO	PART#	DESCRIPTION
1	37-7033	MOTOR 5HP 1750 208/230/460 CLOSE COUPLED 3PH
2	99-7778	PUMP 6 GPM VANE
3	50-0159	WASHER 3/8 LOCK ZINC
4	50-0012	BOLT 3/8-16 X 1 1/4 HHCS
5	20-0197	BREATHER 3/4 FILLER
6	60-0011	DECAL MOTOR ROTATION
7	20-0555	ELL 1/2 NPTM
8	20-0035	TEE 1/2 NPTF
9	20-0204	CHECK VALVE 1/2 NPTF
10	20-0040	ADAPTER 3/8 NPTF X 1/2 NPTM
11	20-0025	NIPPLE 3/8 NPT
12	20-0859	VALVE CHECK 3/8 NPTF AIR BLEED
13	20-0238	ELL 1 NPTM X 1 NPTF 90 STREETSCH 40
14	20-0363	1 SCH 40 MS X 10 1/4
15	20-0050	FILTER SUCTION 13 GPM
16	20-0037	COUPLING 1/2 NPT SCH 80
17	20-0328	HOSE END 1/2 WB X 1/2 SW NPTM
18	20-0329	HOSE END 1/2 WB X 1/2 NPTM
19	20-0264	SUBPLATE
20	20-0132	ADAPTER 1/2 NPTF X 3/4 NPTMSCH 80
21	50-0154	BOLT 5/16-18 X 2 1/4 SHCS
22	50-0105	NUT 5/16-18 HEX SELF-LOCKING
23	20-0214	VALVE RELIEF 20 GPM CART PILOT OP
24	20-0157	VALVE 4-WAY 05 O 2-POS
25	20-0039	ELL 1/2 NPTM X 1/2 NPTF 90
26	20-0265	ELL 1/2 NPTM X 1/2 NPTF W/1/4HOLE 90
27	20-0065	PLUG 1/4 NPT SOCKET HEAD
28	20-0254	PLUG 2 NPT SQ HD
29	20-0330	HOSE 1/2 WB 3500PSI
30	06-0007	SEAL RUBBER 42 VP# 187 UC
31	20-0198	GAUGE SIGHT LEVEL 3 INCH

RamJet Self-Contained Compactor Container

Replacement Parts

POWER UNIT - 10 HP

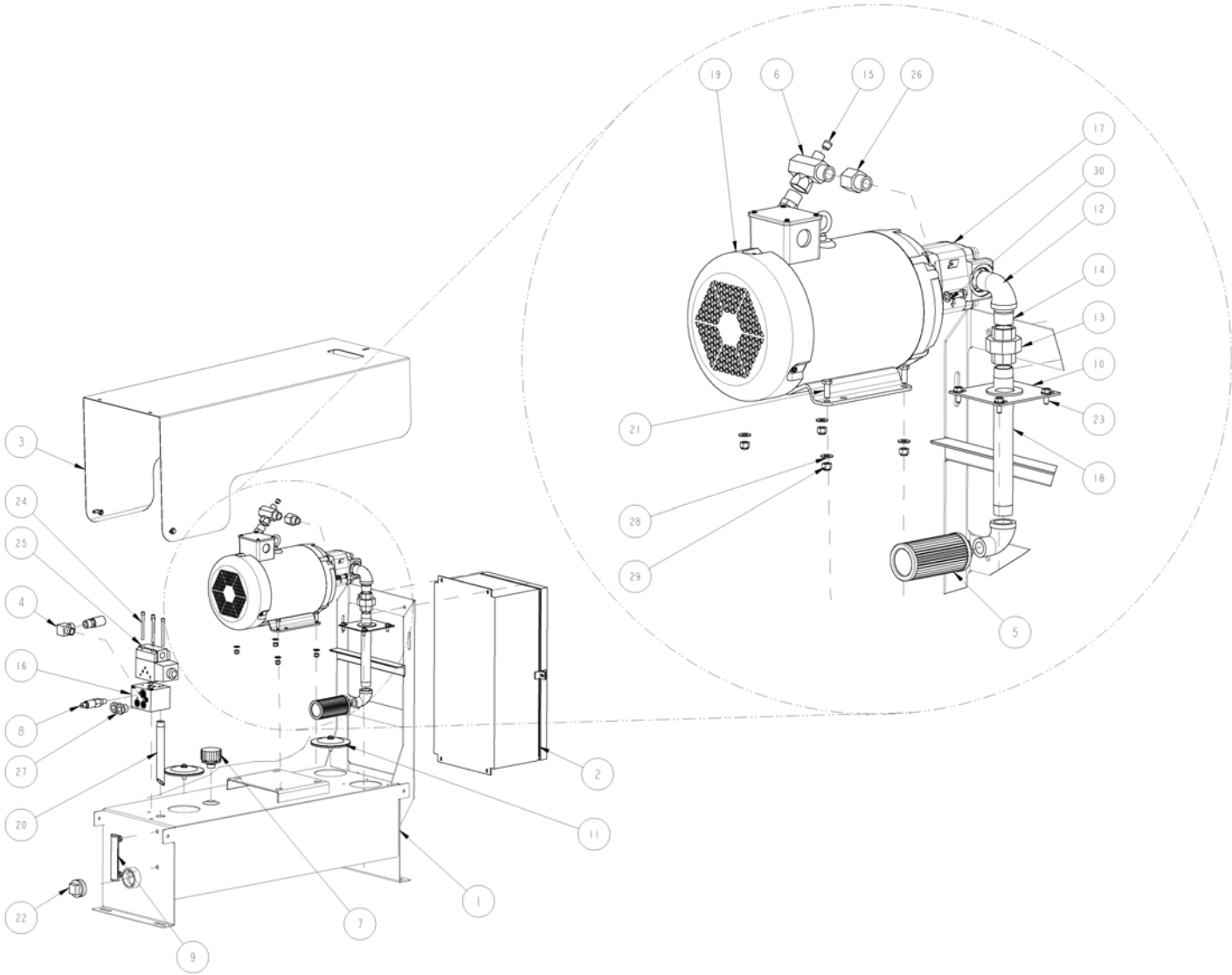

POWER UNIT - 10 HP - PARTS LIST

Match reference number with the drawings on this page. To order replacement parts, call our Parts Department at 800-528-5308.

RamJet Self-Contained Compactor Container

Replacement Parts

POWER UNIT - 10 HP - PARTS LIST

Item no	Part #	Description
1	461333	RESERVOIR UNIV PPK 20GAL
2	03-0527	ENCLOSURE 12 1/2 X 24 X 8 NEMA
3	459306	WEATHER COVER (INCLUDES HARDWARE)
4	02-0044	ELL 3/4 NPTM X 3/4 NPTF 90
5	02-0050	FILTER SUCTION 1 13 GPM 100 ME
6	02-1042	VALVE CHECK 3/4 NPTM X 3/4 NPT
7	02-0197	BREATHER 3/4 FILLER
8	02-0214	VALVE RELIEF 20 GPM CART PILOT
9	02-0215	GAUGE SIGHT LEVEL 5 INCH
10	02-0218	FLANGE SUCTION 1 PIPE
11	02-0219	CLEAN OUT COVER 6
12	02-0238	ELL 1 NPTM X 1 NPTF 90 STREET
13	02-0239	UNION 1 NPT
14	02-0240	NIPPLE 1 NPT CLOSE
15	02-0065	PLUG 1/4 NPT SOCKET HEAD
16	02-6243	SUBPLATE 05 1 STN 3/4 NPTF R
17	02-0267	PUMP 9 GPM GEAR
18	02-0363	PIPE 1 SCH 40 X 10 1/4
19	03-7030	MOTOR 10HP 208/230/460V 60HZ
20	35-8461	PIPE 3/4 SCH 40 X 9 RETURN
21	05-0096	BOLT 3/8-16 X 1 HHCS
22	02-0254	PLUG 2 NPT SQ HD
23	05-0225	SCREW 5/16-18 X 3/4 ST TYPE 23
24	05-0662	BOLT 5/16-18 X 3 1/2 SHCS
25	02-0157	VALVE 4-WAY 05 O 2-POS
26	02-3387	ADAPTER 3/4 NPTM X 3/4 NPTF
27	02-0132	ADAPTER 1/2 NPTF X 3/4 NPTM
28	05-0016	WASHER 3/8 FLAT ZINC
29	05-0015	NUT 3/8-16 HEX SELF LOCKING
30	05-0159	WASHER 3/8 LOCK ZINC

RamJet Self-Contained Compactor Container

Replacement Parts

POWER UNIT WITH INTEGRAL DUMPER - 10 HP

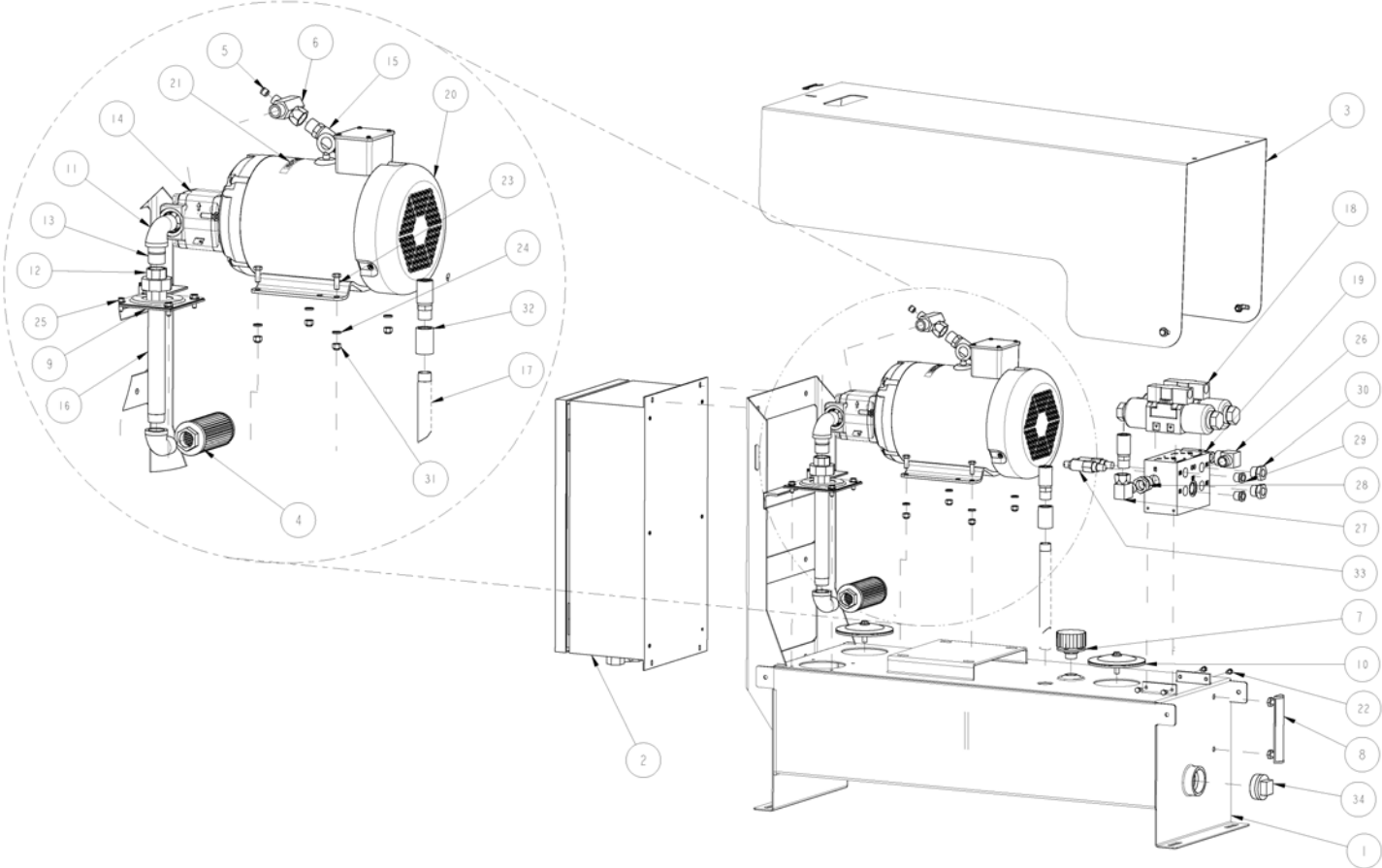

RamJet Self-Contained Compactor Container

Replacement Parts

POWER UNIT WITH INTEGRAL DUMPER - 10 HP - PARTS LIST

Match reference number with the drawings on the previous page. To order replacement parts, call our Parts Department at 800-528-5308.

PPK 603860		
Item #	Part #	Description
1	461333	RESERVOIR UNIV PPK 20GAL
2	03-0527	ENCLOSURE 12 1/2 X 24 X 8 NEMA
3	459306	WEATHER COVER (INCLUDES HARDWARE)
4	02-0050	FILTER SUCTION 1 13 GPM 100 ME
5	02-0065	PLUG 1/4 NPT SOCKET HEAD
6	02-1042	VALVE CHECK 3/4 NPTM X 3/4 NPT
7	02-0197	BREATHER 3/4 FILLER
8	02-0215	GAUGE SIGHT LEVEL 5 INCH
9	02-0218	FLANGE SUCTION 1 PIPE
10	02-0219	CLEAN OUT COVER 6
11	02-0238	ELL 1 NPTM X 1 NPTF 90 STREET
12	02-0239	UNION 1 NPT
13	02-0240	NIPPLE 1 NPT CLOSE
14	02-0267	PUMP 9 GPM GEAR
15	02-0326	HOSE END 3/4 WB X 3/4 NPTM
16	02-0363	PIPE 1 SCH 40 X 10 1/4
17	35-8461	PIPE 3/4 SCH 40 X 9 RETURN
18	02-0852	VALVE 4-WAY 05 T 3 SOFT SHIFT
19	02-6153	SUBPLATE 05 2 STN W/CV&RV
20	03-7030	MOTOR 10HP 208/230/460V 60HZ
21	06-0011	DECAL MOTOR ROTATION 3/4 X 4
22	05-0024	BOLT 1/4- 20 X 1/2 HHCS PLT
23	05-0096	BOLT 3/8-16 X 1 HHCS
24	05-0159	WASHER 3/8 LOCK ZINC
25	05-0225	SCREW 5/16-18 X 3/4 ST TYPE 23

RamJet Self-Contained Compactor Container

Replacement Parts

POWER UNIT WITH INTEGRAL DUMPER - 10 HP - PARTS LIST (CONTINUED)

26	02-0044	ELL 3/4 NPTM X 3/4 NPTF 90
27	02-0041	ELL 3/4 NPTM X 3/4 NPTF SWV 90
28	02-0060	ADAPTER 3/4 NPTF X 1 NPTM
29	02-0040	ADAPTER 3/8 NPTF X 1/2 NPTM
30	02-0132	ADAPTER 1/2 NPTF X 3/4 NPTM
30	05-0015	NUT 3/8-16 HEX SELF LOCKING
32	02-0129	COUPLING 3/4 NPT SCH 80
33	02-0214	VALVE RELIEF 20GPM CART PILOT OP
34	02-0254	PLUG 2 NPT SQ HD

RamJet Self-Contained Compactor Container

Replacement Parts

TYPICAL PANEL BOX CONFIGURATION

The diagram below represents a typical panel box configuration for the self-contained compactors. The panel box on your compactor may differ depending on the model and/or optional equipment/controls. Refer to the chart below to identify components. To order replacement parts, please call our Parts Department at 800-528-5308.

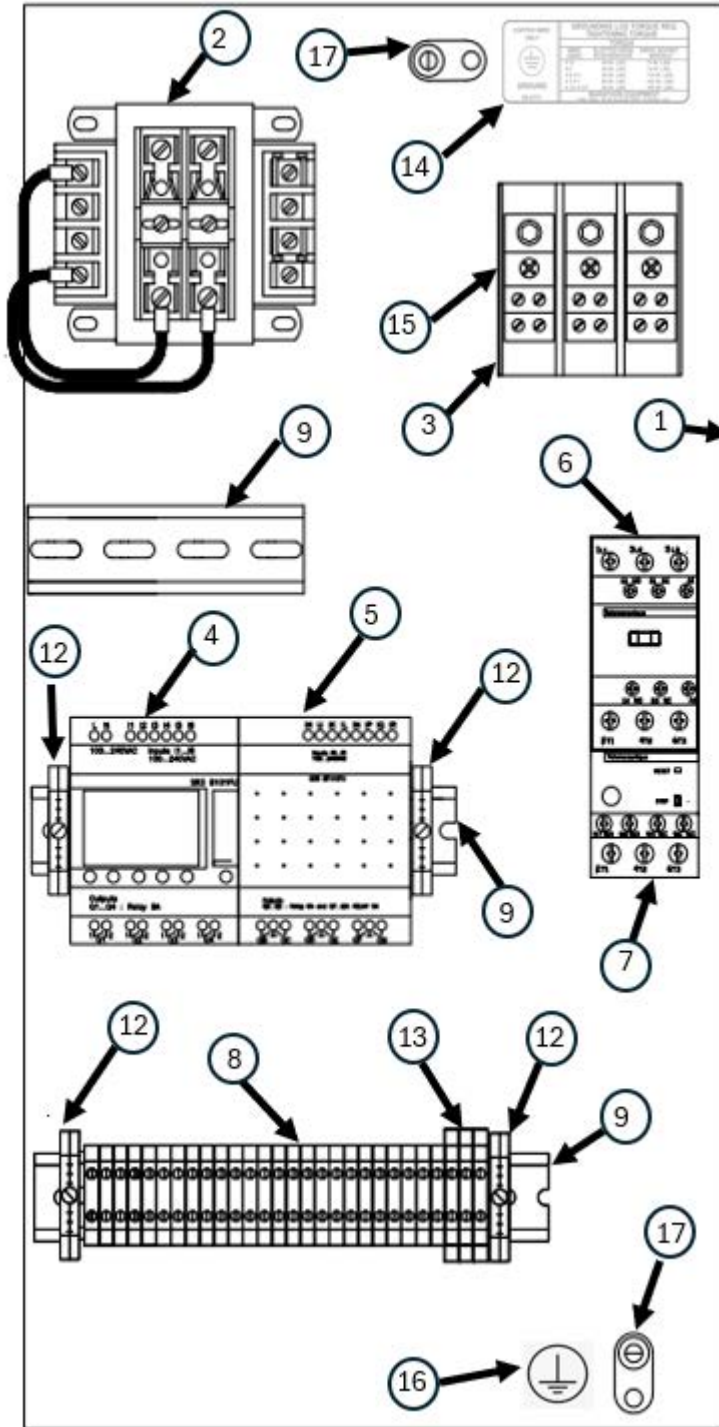

RamJet Self-Contained Compactor Container

Replacement Parts

ELECTRICAL PARTS LIST

ITEM	Part #	DESCRIPTION
1	03-0527	ENCLOSURE
2	03-0288	TRANSFORMER 150VA, 208/230/460/120 VAC
3	03-0959	DISTRIBUTION BLOCK
4	03-4729	ZELIO SMART RELAY - PLC
5	03-4852	ZELIO EXPANSION MODULE - 6 INPUTS, 4 OUTPUTS
	03-5483	ZELIO EXPANSION MODULE - 8 INPUTS, 6 OUTPUTS
6	03-4748	IEC MOTOR STARTER
7	03-4753	OVERLOAD FOR 460V
	03-4763	OVERLOAD FOR 230V
8	03-4437	IEC FINGER-SAFE TERMINAL BLOCKS
9	03-7419	DIN RAIL
10	03-0488	FUSE 1.5 AMP(NOT SHOWN)
11	03-0191	FUSE 2.0 AMP(NOT SHOWN)
12	03-4441	TERMINAL END STOP
13	03-4172	TERMINAL GROUND
14	06-0374	DECAL GROUND
15	06-3951	DECAL LINE L1,L2,L3
16	06-0427	DECAL PE GROUND CE
17	03-0551	GROUND LUG

See Power Unit - Standard 5 HP Parts List [87](#) or Power Unit - 10 HP Parts List [89](#) for additional replacement parts.

RamJet Self-Contained Compactor Container

Replacement Parts

DECAL PLACEMENT

Match part numbers on this chart for the 100SC. See Decal Images .

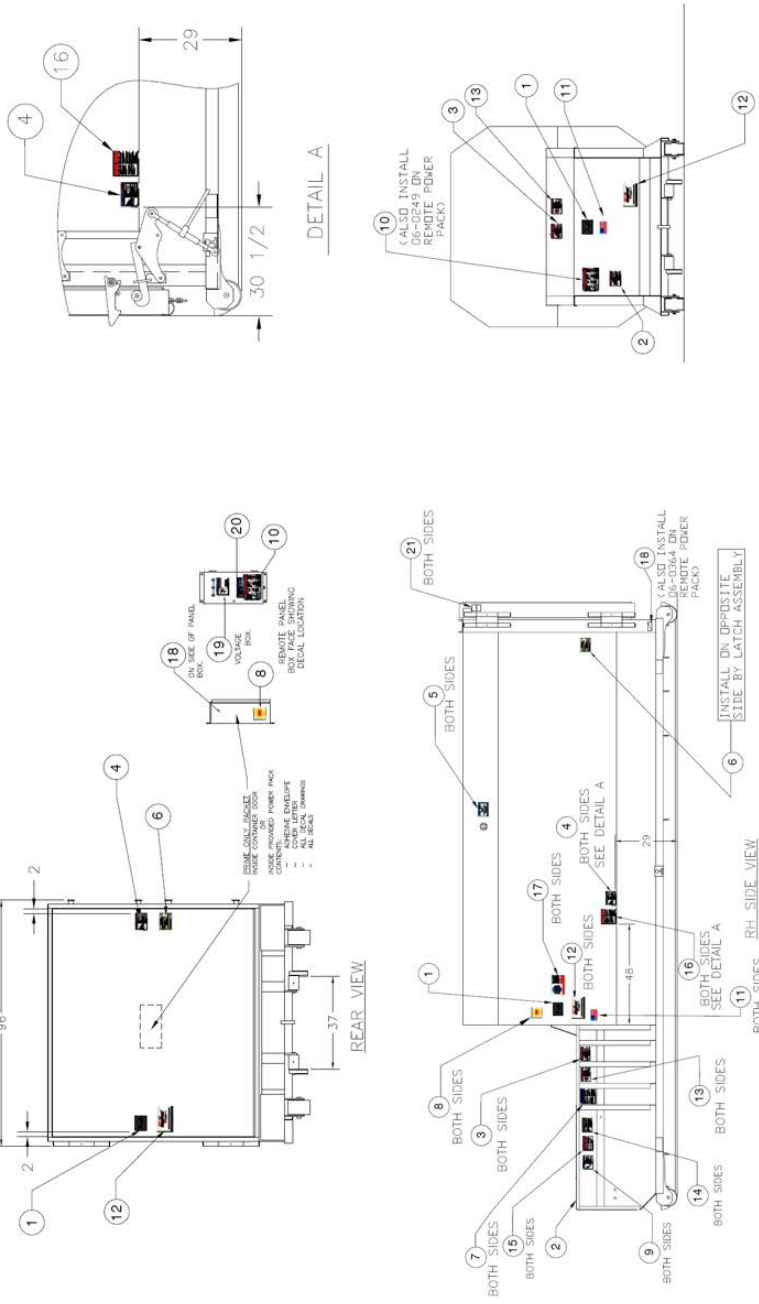

RamJet Self-Contained Compactor Container

Replacement Parts

DECAL PLACEMENT (CONTINUED)

ITEM	PART #	DESCRIPTION E/S
1	06-0002	DECAL RAM-JET
2	06-0038	DECAL DANGER DO NOT REMOVE ACCESS E/S
3	06-0039	DECAL DANGER DO NOT ENTER E/S
4	06-0057	DECAL WARNING STAND CLEAR OF CON
5	06-0093	DECAL FIRE HOSE PORT
6	06-0094	DECAL NOTICE WIPE OFF SEAL AFTER
7	06-0121	DECAL NOTICE FEDERAL REGULATION PROHIBIT..UNDER 18 E/S
8	06-0124	DECAL CYCON
9	06-0133	DECAL WARNING STAY OFF..DO NOT CLIMB E/S
10	06-0249	DECAL DANGER HAZARDOUS VOLTAGE
11	06-1839	DECAL AMERICAN FLAG
12	06-2751	DECAL MARATHON COMP & RECYC SOLUTIONS
13	06-3123	DECAL DANGER CONFINED SPACE E/S
14	06-3977	DECAL WARNING DO NOT OPERATE OR SERVICE E/S
15	06-3978	DECAL DANGER DO NOT OVERRIDE OR TAMPER E/S
16	06-4405	DECAL DANGER CHAIN KEEPER INSTRUCTIONS E/S
17	06-4839	DECAL MARATHON WARRANTY
18	06-0364	DECAL COMPACTOR SERIAL NUMBER UL "MADE IN USA"
19	06-3044	DECAL DANGER VOLTS W/BLANK SPACE E/S
20	06-3976	DECAL WARNING SHOCK ARC FLASH HAZARD E/S
21	06-4973	DECAL NO LIFT POINT SIGN

RamJet Self-Contained Compactor Container

Replacement Parts

DECAL PLACEMENT (CONTINUED)

ITEM	PART #	DESCRIPTION E/F
1	06-0502	DECAL RAM-JET
2	06-0504	DECAL DANGER DO NOT REMOVE ACCESS E/F
3	06-0505	DECAL DANGER DO NOT ENTER E/F
4	06-0521	DECAL WARNING STAND CLEAR OF CONT
5	06-0526	DECAL FIRE HOSE PORT
6	06-0527	DECAL NOTICE WIPE OFF SEAL
7	06-0696	DECAL NOTICE FEDERAL REGULATION PROHIBIT..UNDER18 E/F
8	06-0124	DECAL CYCON
9	06-0520	DECAL WARNING STAY OFF..DO NOT CLIMB E/F
10	06-0508	DECAL DANGER HAZARDOUS VOLTAGE
11	06-1839	DECAL AMERICAN FLAG
12	06-2751	DECAL MARATHON COMP & RECYC SOLUTIONS
13	06-3189	DECAL DANGER CONFINED SPACE E/F
14	06-3188	DECAL WARNING DO NOT OPERATE OR SERVICE E/F
15	06-3989	DECAL DANGER DO NOT OVERRIDE OR TAMPER E/F
16	06-4030	DECAL DANGER CHAIN KEEPER INSTRUCTIONS E/F
17	06-4939	DECAL MARATHON WARRANTY
18	06-0364	DECAL COMPACTOR SERIAL NUMBER UL "MADE IN USA"
19	06-3414	DECAL DANGER VOLTS W/BLANK SPACE E/F
20	06-3987	DECAL WARNING SHOCK ARC FLASH HAZARD E/F
21	06-4973	DECAL NO LIFT POINT SIGN

RamJet Self-Contained Compactor Container

Replacement Parts

DECAL PLACEMENT (CONTINUED)

ITEM	PART #	DESCRIPTION E/S
1	06-0002	DECAL RAM-JET
2	06-0038	DECAL DANGER DO NOT REMOVE ACCESS E/S
3	06-0039	DECAL DANGER DO NOT ENTER E/S
4	06-0057	DECAL WARNING STAND CLEAR OF CONT
5	06-0093	DECAL FIRE HOSE PORT
6	06-0094	DECAL NOTICE WIPE OFF SEAL AFTER
7	06-0121	DECAL NOTICE FEDERAL REGULATION PROHIBIT..UNDER 18 E/S
8	06-0124	DECAL CYCON
9	06-0133	DECAL WARNING STAY OFF..DO NOT CLIMB E/S
10	06-0249	DECAL DANGER HAZARDOUS VOLTAGE E/S
11	06-1839	DECAL AMERICAN FLAG
12	06-2751	DECAL MARATHON COMP & RECYCSOLUTIONS
13	06-3123	DECAL DANGER CONFINED SPACE E/S
14	06-3726	DECAL, SIGNATURE SERIES
15	06-3977	DECAL WARNING DO NOT OPERATE OR SERVICE E/S
16	06-3978	DECAL DANGER DO NOT OVERRIDE OR TAMPER E/S
17	06-4405	DECAL DANGER CHAIN KEEPER INSTRUCTIONS E/S
18	06-4839	DECAL MARATHON WARRANTY
19	06-3448	DECAL GREENBUILT
20	06-3546	DECAL SOLAR POWER UNIT
21	06-0364	DECAL COMPACTOR SERIAL NUMBER UL "MADE IN USA"
22	06-3044	DECAL DANGER VOLTS W/BLANK SPACE E/S
23	06-3976	DECAL WARNING SHOCK ARC FLASH HAZARD E/S
24	06-4973	DECAL NO LIFT POINT SIGN

RamJet Self-Contained Compactor Container

Replacement Parts

DECAL PLACEMENT (CONTINUED)

ITEM	PART #	DESCRIPTION E/F
1	06-0002	DECAL RAM-JET
2	06-0504	DECAL DANGER DO NOT REMOVE ACCESS E/F
3	06-0505	DECAL DANGER DO NOT ENTER E/F
4	06-0521	DECAL WARNING STAND CLEAR OF CONT
5	06-0526	DECAL FIRE HOSE PORT
6	06-0527	DECAL NOTICE WIPE OFF SEAL
7	06-0696	DECAL NOTICE FEDERAL REGULATION PROHIBIT..UNDER18 E/F
8	06-0124	DECAL CYCON
9	06-0520	DECAL WARNING STAY OFF..DO NOT CLIMB E/F
10	06-0508	DECAL DANGER HAZARDOUS VOLTAGE E/F
11	06-1839	DECAL AMERICAN FLAG
12	06-2751	DECAL MARATHON COMP & RECYCSOLUTIONS
13	06-3189	DECAL DANGER CONFINED SPACE E/F
14	06-3726	DECAL, SIGNATURE SERIES
15	06-3988	DECAL WARNING DO NOT OPERATE OR SERVICE E/F
16	06-3989	DECAL DANGER DO NOT OVERRIDE OR TAMPER E/F
17	06-4430	DECAL DANGER CHAIN KEEPER INSTRUCTIONS E/F
18	06-4839	DECAL MARATHON WARRANTY
19	06-3448	DECAL GREENBUILT
20	06-3546	DECAL SOLAR POWER UNIT
21	06-0364	DECAL COMPACTOR SERIAL NUMBER UL "MADE IN USA"
22	06-3414	DECAL DANGER VOLTS W/BLANK SPACE E/F
23	06-3987	DECAL WARNING SHOCK ARC FLASH HAZARD E/F
24	06-4973	DECAL NO LIFT POINT SIGN

RamJet Self-Contained Compactor Container

Replacement Parts

DECAL PLACEMENT (CONTINUED)

Match part numbers on this chart for the 250 WD. See Decal Images  110.

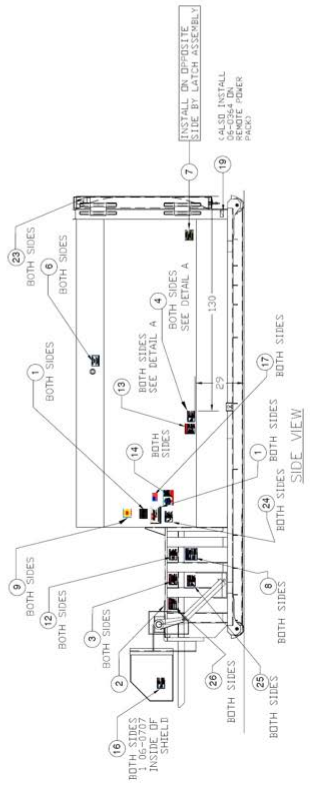
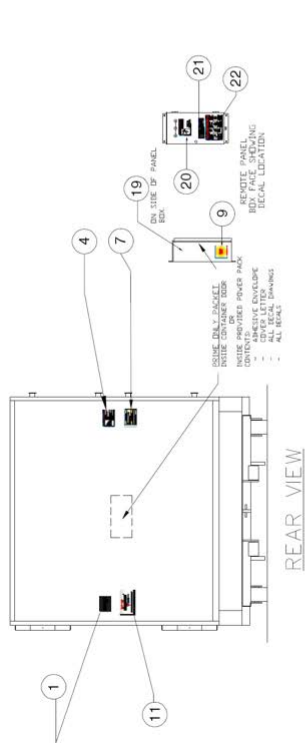
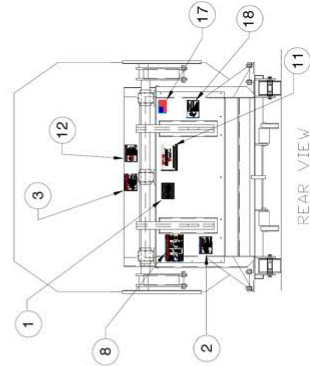
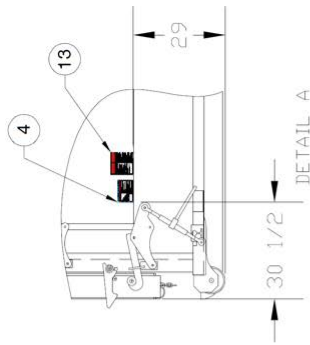

RamJet Self-Contained Compactor Container

Replacement Parts

DECAL PLACEMENT (CONTINUED)

ITEM	PART #	DESCRIPTION E/S
1	06-0002	DECAL RAM-JET
2	06-0038	DECAL DANGER DO NOT REMOVE ACCESS E/S
3	06-0039	DECAL DANGER DO NOT ENTER E/S
4	06-0057	DECAL WARNING STAND CLEAR OF CON
5	06-0087	DECAL WARNING OPERATOR
6	06-0093	DECAL FIRE HOSE PORT
7	06-0094	DECAL NOTICE WIPE OFF SEAL AFTER
8	06-0121	DECAL NOTICE FEDERAL REGULATION PROHIBIT..UNDER 18 E/S
9	06-0124	DECAL CYCON
10	06-0133	DECAL WARNING STAY OFF..DO NOT CLIMB E/S
11	06-2751	DECAL MARATHON COMP & RECYCSOLUTIONS 6X10
12	06-3123	DECAL DANGER CONFINED SPACE E/S
13	06-4405	DECAL DANGER CHAIN KEEPER INSTRUCTIONS E/S
14	06-4839	DECAL MARATHON WARRANTY
15	06-0067	DECAL D/N REMOVE CONT TIL REAR
16	06-0411	DECAL DANGER STAY CLEAR OF DUM PER
17	06-1839	DECAL AMERICAN FLAG
18	06-0087	DECAL WARNING OPERATOR E/S
19	06-0364	DECAL COMPACTOR SERIAL NUMBER UL "MADE IN USA"
20	06-3044	DECAL DANGER VOLTS W/BLANK SPACE E/S
21	06-3976	DECAL WARNING SHOCK ARC FLASH HAZARD E/S
22	06-0249	DECAL DANGER HAZARDOUS VOLTAGE
23	06-4973	DECAL NO LIFT POINT SIGN
24	06-0133	DECAL WARNING STAY OFF..DO NOT CLIMB E/S
25	06-3977	DECAL WARNING DO NOT OPERATE OR SERVICE E/S
26	06-3978	DECAL DANGER DO NOT OVERRIDE OR TAMPER E/S

RamJet Self-Contained Compactor Container

Replacement Parts

DECAL PLACEMENT (CONTINUED)

ITEM	PART #	DESCRIPTION E/F
1	06-0002	DECAL RAM-JET
2	06-0504	DECAL DANGER DO NOT REMOVE ACCESS E/F
3	06-0505	DECAL DANGER DO NOT ENTER E/F
4	06-0521	DECAL WARNING STAND CLEAR OF CONT
5	06-0087	DECAL WARNING OPERATOR
6	06-0526	DECAL FIRE HOSE PORT
7	06-0527	DECAL NOTICE WIPE OFF SEAL
8	06-0696	DECAL NOTICE FEDERAL REGULATION PROHIBIT..UNDER18 F
9	06-0124	DECAL CYCON
10	06-0520	DECAL WARNING STAY OFF..DO NOT CLIMB E/F
11	06-2751	DECAL MARATHON COMP & RECYCSOLUTIONS 6X10
12	06-3189	DECAL DANGER CONFINED SPACE E/F
13	06-4430	DECAL DANGER CHAIN KEEPER INSTRUCTIONS E/F
14	06-4839	DECAL MARATHON WARRANTY
15	06-0524	DECAL D/N REMOVE CONT TIL STPS FR/ENG
16	06-0707	DECAL, DANGER STAY CLEAR OF DUMPER ENG/FRENCH
17	06-1839	DECAL AMERICAN FLAG
18	06-0685	DECAL WARNING OPERATOR E/F
19	06-0364	DECAL COMPACTOR SERIAL NUMBER UL "MADE IN USA"
20	06-3414	DECAL DANGER VOLTS W/BLANKSPACE E/F
21	06-3987	DECAL WARNING SHOCK ARC FLASH HAZARD E/F
22	06-0249	DECAL DANGER HAZARDOUS VOLTAGE
23	06-4973	DECAL NO LIFT POINT SIGN
24	06-0520	DECAL WARNING STAY OFF..DO NOT CLIMB E/F
25	06-3988	DECAL WARNING DO NOT OPERATE OR SERVICE E/F
26	06-3989	DECAL DANGER DO NOT OVERRIDE OR TAMPER E/F

RamJet Self-Contained Compactor Container

Replacement Parts

DECAL PLACEMENT (CONTINUED)

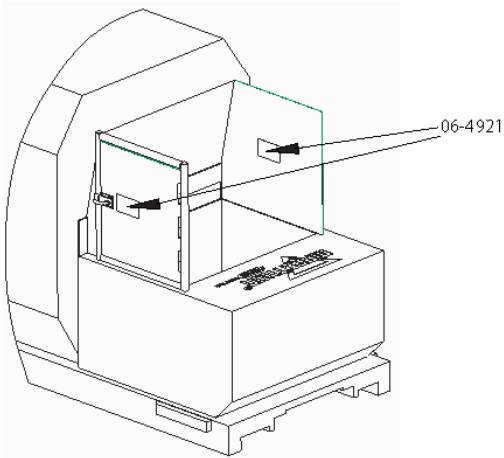

Decal on outside and inside of door and on inside wall opposite of door.

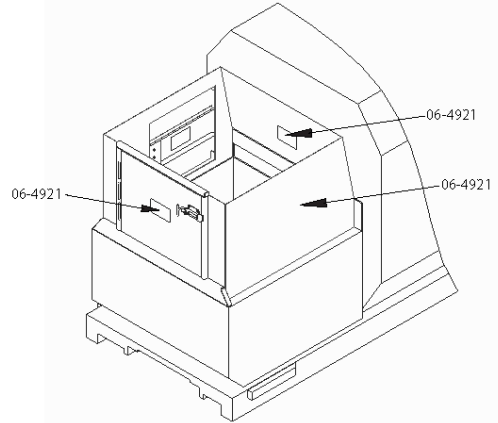

Decal on outside and inside of all doors and on inside back wall of doghouse opposite of rear door.

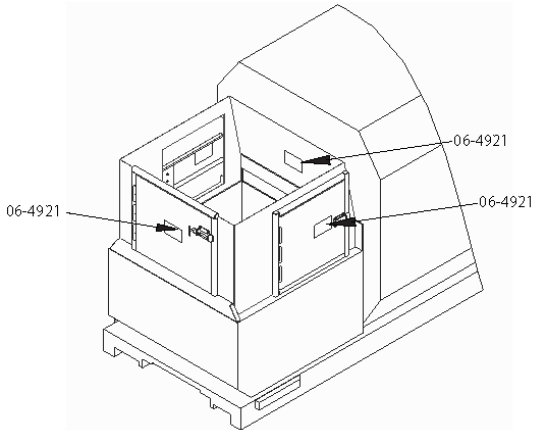

Decal on outside and inside of all doors and on inside back wall of doghouse opposite of rear door.

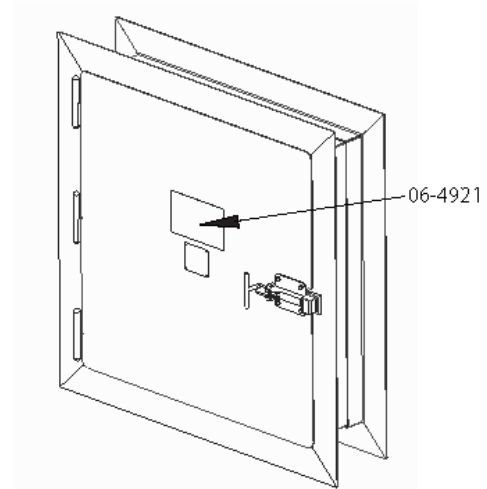

Decal on outside and inside of door

RamJet Self-Contained Compactor Container

Replacement Parts

DECAL PLACEMENT FOR (CONTINUED)

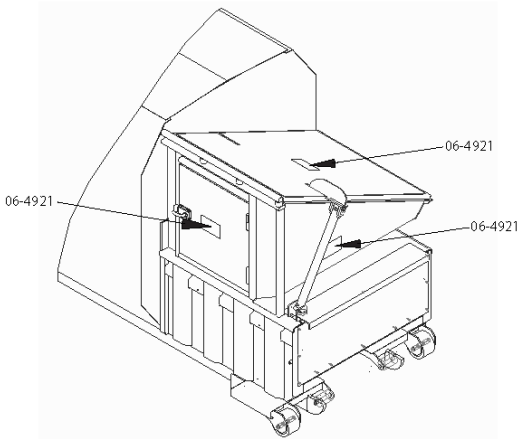

Decal on rear outside hopper wall and on outside and inside of door and lid.

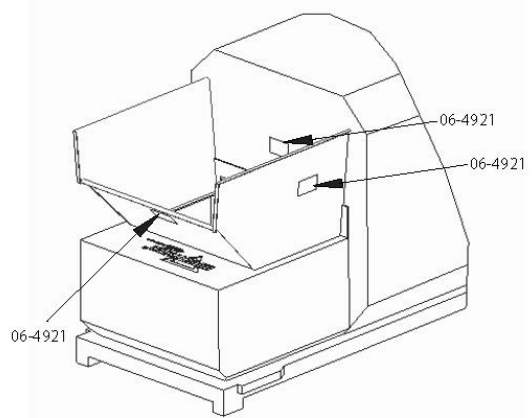

Decal on outside of all hopper walls and on back container wall or hopper wall opposite of loading position.

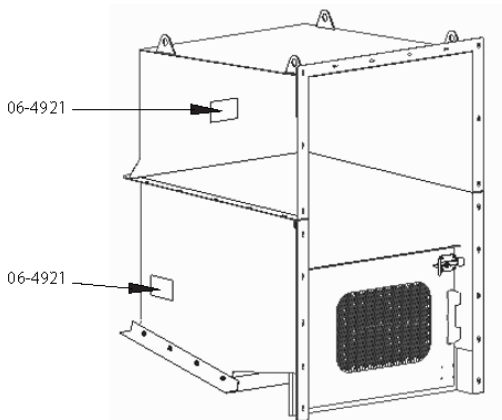

Decal on outside of all lower walls and on inside back wall opposite of loading position.

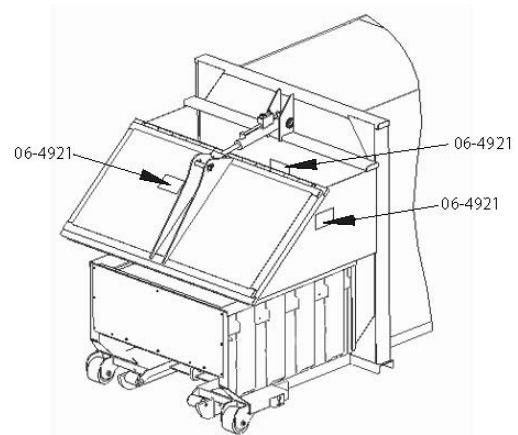

Decal on outside and inside of lid, on outside of both side walls and on inside wall opposite of door.

RamJet Self-Contained Compactor Container

Replacement Parts

DECAL PLACEMENT FOR (CONTINUED)

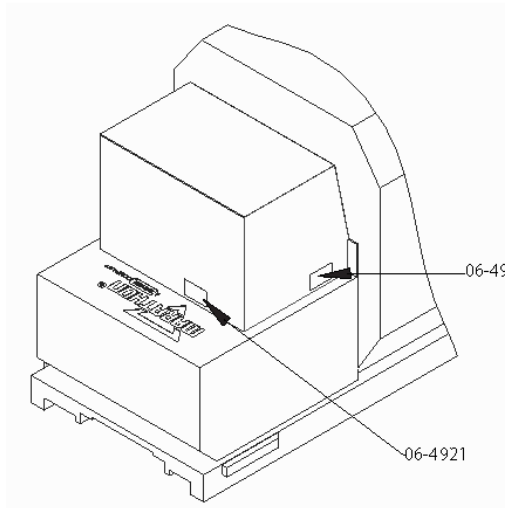

Decal on outside of all walls.

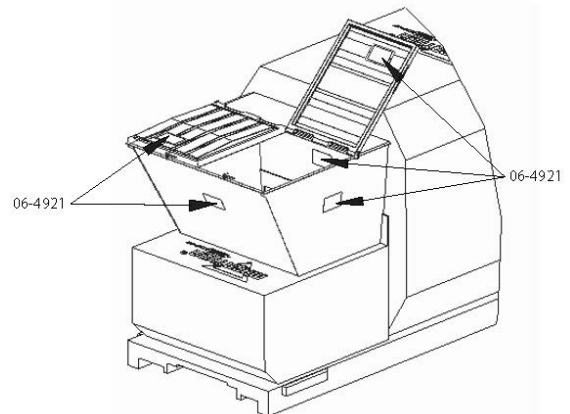

Decal on outside of all walls, on back container wall or hopper wall opposite of loading position and on outside and inside of all lids.

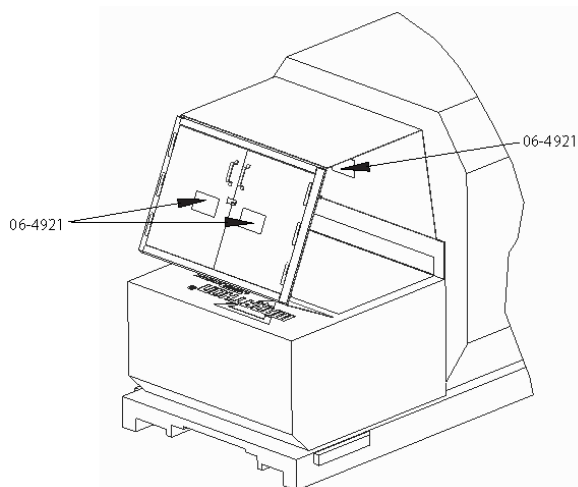

Decal on outside and inside of all doors and on back wall opposite of loading position.

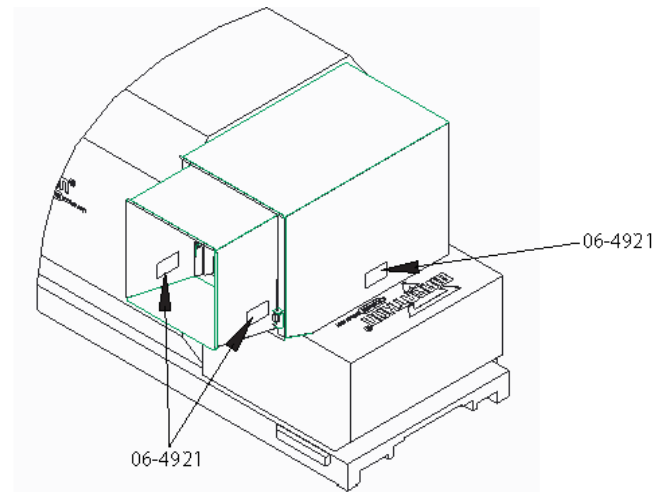

Decal on outside of all side walls, on both sides of telescoping chute and on inside of telescoping chute.

RamJet Self-Contained Compactor Container

Replacement Parts

DECAL PLACEMENT FOR (CONTINUED)

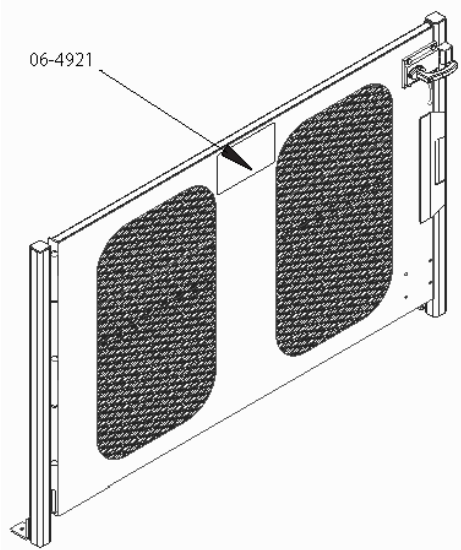

Decal on front of gate

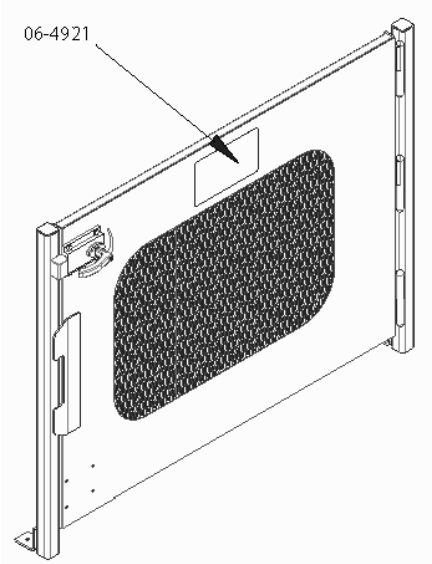

Decal on front of gate

RamJet Self-Contained Compactor Container

Replacement Parts

DECAL LIST

Warning Decal Requirements

When your compactor leaves the factory, several WARNING DECALS are installed for your protection. These labels are subject to wear and abuse due to the nature of operation. The FOLLOWING DECALS MUST BE MAINTAINED. Additional decals may be purchased through your distributor or from Marathon Equipment Company by calling the parts department at 800-528-5308.

When ordering replacement decals, use the chart below with the **Decal Placement Drawing** ⁹⁵ or look for the part number in the lower right hand corner of the decal. For optional equipment or HT Models, see **Decals for Optional Loading Configurations** and **Decals for Hydraulic Tailgate (HT) Units** ¹¹⁵.

PART #	DESCRIPTION	QTY
06-0002	RAM-JET	3
06-0038	WARNING DO NOT REMOVE ACCESS COVER	2
06-0039	DANGER DO NOT ENTER	3
06-0057	WARNING STAND CLEAR OF COMPACTOR	3
06-0087	WARNING CRUSH HAZARD	2
06-0093	FIRE HOSE PORT	2
06-0094	NOTICE WIPE OFF SEAL AFTER....	2
06-0097	MARATHON SERIAL PLATE	1
06-0121	NOTICE FEDERAL REGULATION...NO <18 y.o.	2
06-0124	CYCON	2
06-0133	WARNING, KEEP OFF, DO NOT CLIMB	2
06-0249	DANGER HAZARDOUS VOLTAGE	1
06-0364	COMPACTOR SERIAL NUMBER	2
06-0411	DANGER CRUSH HAZARD	3
06-0504	DANGER CRUSHING HAZARD ENGLISH/SPANISH	2
06-0505	DANGER CRUSHING HAZARD ENGLISH/FRENCH	1
06-0508	DANGER HIGH VOLTAGE ENGLISH/SPANISH	2
06-0520	WARNING KEEP OFF FALL/CRUSH HAZARD	2
06-0521	DANGER CRUSHING HAZARD ENGLISH/FRENCH	2
06-0526	FIRE HOSE PORT	2
06-0527	CAUTION WIPE OFF SEAL	1
06-0696	NOTICE AUTHORIZED OPERATORS ONLY	1
06-1839	AMERICAN FLAG	3

RamJet Self-Contained Compactor Container

Replacement Parts

DECAL LIST (CONTINUED)

06-2751	MARATHON	3
06-3044	DANGER, HAZARDOUS VOLTAGE	1
06-3123*	CONFINED SPACE	3
06-3189	DANGER PERMIT REQUIRED CONFINED SPACE	1
06-3231	ULTRA DECAL	2
06-3448	GREENBUILT	3
06-3546	MARATHON SOLAR	1
06-3726	SIGNATURE SERIES	2
06-3976	WARNING, SHOCK AND ARC FLASH HAZARD	1
06-3977	WARNING DO NOT OPERATE OR SERVICE	2
06-3978	DANGER, SAFETY DEVICES	2
06-3988	DECAL WARNING DO NOT OPERATE	4
06-3989	DECAL DANGER DO NOT OVERRIDE	4
06-4405	DANGER OPEN TAILGATE FULLY	1
06-4430	DANGER OPEN TAILGATE FULLY	2
06-4766	SC2 LOGO	1
06-4839	WARRANTY	1
06-4921	DECAL, DANGER DO NOT ENTER ENGLISH/SPANISH	3
06-4924	DECAL, DANGER DO NOT ENTER ENGLISH/FRENCH	3
06-4973	DECAL NO LIFT POINT SIGN	2

RamJet Self-Contained Compactor Container Replacement Parts

DECAL IMAGES

06-0002



06-0038



06-0039



06-0057



06-0087



06-0093



06-0094



06-0097



06-0121

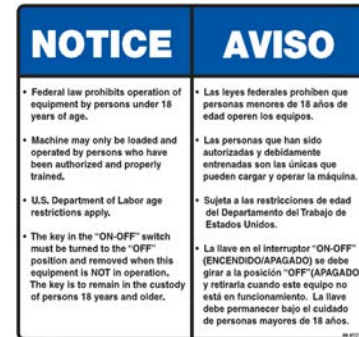

06-0124



06-0133



06-0249

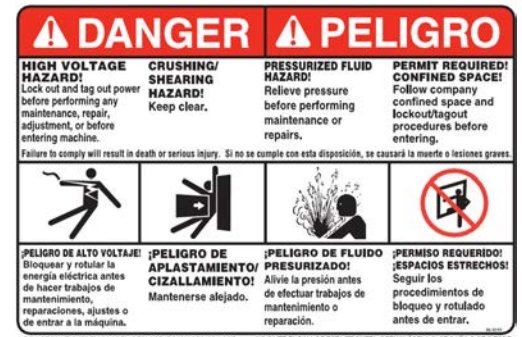

RamJet Self-Contained Compactor Container Replacement Parts

DECAL IMAGES

06-0364

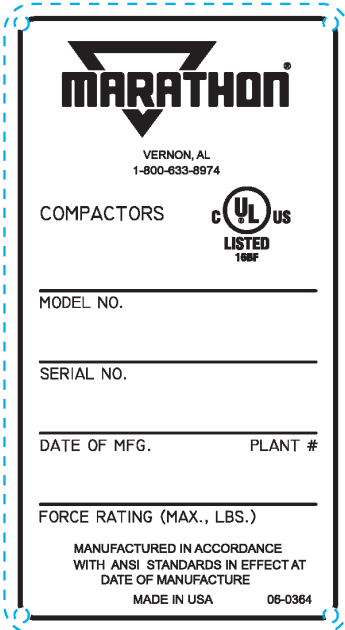

06-0411



06-0504



06-0505



06-0508



06-0520



06-0521

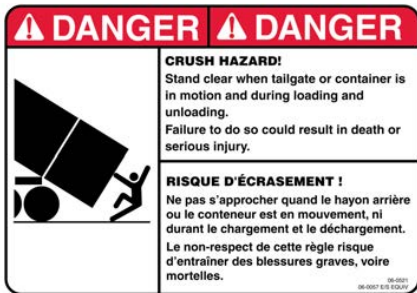

06-0525

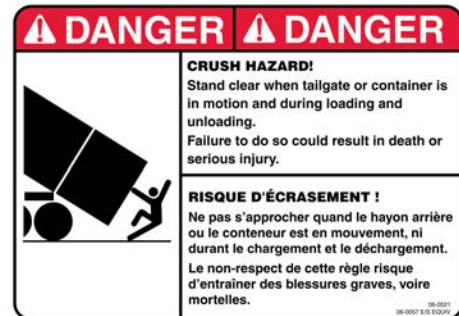

06-0526



RamJet Self-Contained Compactor Container

Replacement Parts

DECAL IMAGES

06-0527



06-0685

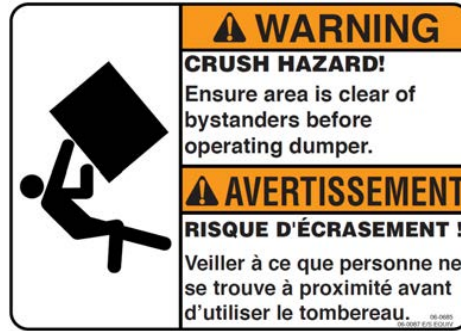

06-0696

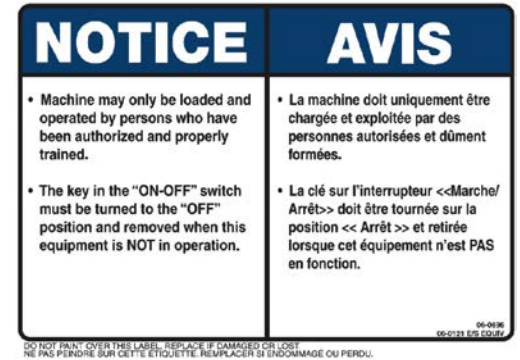

06-0707



06-1839

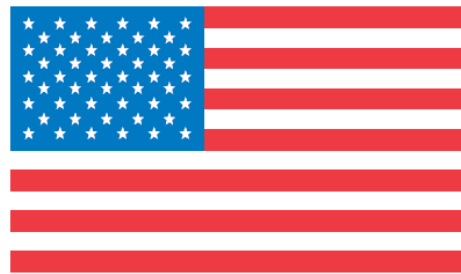

06-2751



06-3044



06-3123



06-3189



06-3231



06-3448



06-3546



RamJet Self-Contained Compactor Container

Replacement Parts

DECAL IMAGES

06-3726



06-3977



DO NOT PAINT OVER THIS LABEL. REPLACE IF DAMAGED OR LOST. NO PINTE ENCIMA DE ESTA ETIQUETA. REEMPLAZELA SI SE DAÑA O SE PIERDE.

06-3978



DO NOT PAINT OVER THIS LABEL. REPLACE IF DAMAGED OR LOST. NO PINTE ENCIMA DE ESTA ETIQUETA. REEMPLAZELA SI SE DAÑA O SE PIERDE.

06-3976

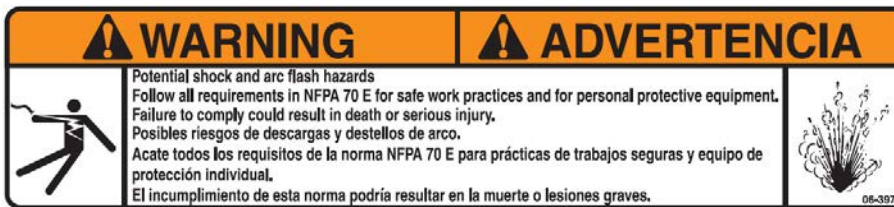

DO NOT PAINT OVER THIS LABEL. REPLACE IF DAMAGED OR LOST. NO PINTE ENCIMA DE ESTA ETIQUETA. REEMPLAZELA SI SE DAÑA O SE PIERDE.

06-3988



DO NOT PAINT OVER THIS LABEL. REPLACE IF DAMAGED OR LOST. NE PAS PEINDRE SUR CETTE ETIQUETTE. REMPLACER SI ENDOMMAGE OU PERDU.

06-3989

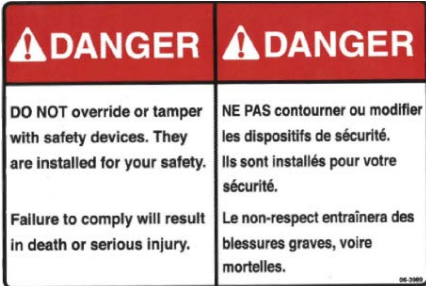

DO NOT PAINT OVER THIS LABEL. REPLACE IF DAMAGED OR LOST. NE PAS PEINDRE SUR CETTE ETIQUETTE. REMPLACER SI ENDOMMAGE OU PERDU.

06-4405



DO NOT PAINT OVER THIS LABEL. REPLACE IF DAMAGED OR LOST. NO PINTE ENCIMA DE ESTA ETIQUETA. REEMPLAZELA SI SE DAÑA O SE PIERDE.

06-4430

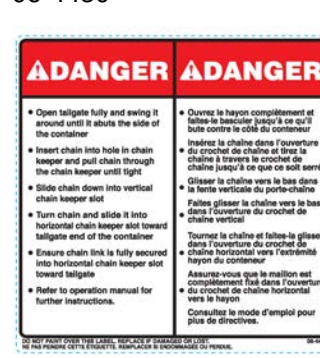

DO NOT PAINT OVER THIS LABEL. REPLACE IF DAMAGED OR LOST. NO PINTE ENCIMA DE ESTA ETIQUETA. REMPLACER SI ENDOMMAGE OU PERDU.

06-4766



06-4839



06-4921



RamJet Self-Contained Compactor Container Replacement Parts

DECAL IMAGES

06-4924



06-4973



RamJet Self-Contained Compactor Container

Replacement Parts

DECALS FOR HYDRAULIC TAILGATE (HT) UNITS

In addition to the decals and their placement specified on the previous pages, the self-contained units with the hydraulic tailgate option require the following decals located as shown below.

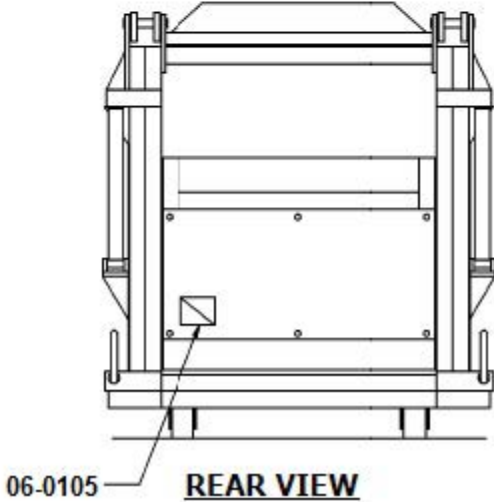
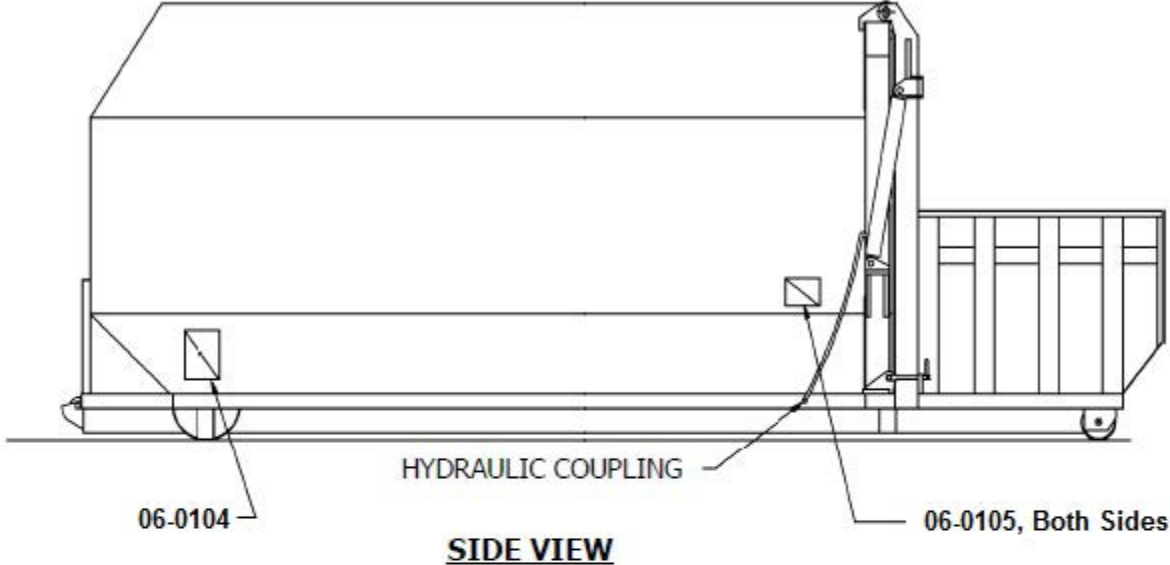

RamJet Self-Contained Compactor Container

Replacement Parts

DECAL PLACEMENT FOR INTEGRAL DUMPER

In addition to the decals from RJ-250SC self-contained compactors and their placement specified in that manual, the self contained units with the integral dumper option require the following decals located as shown below.

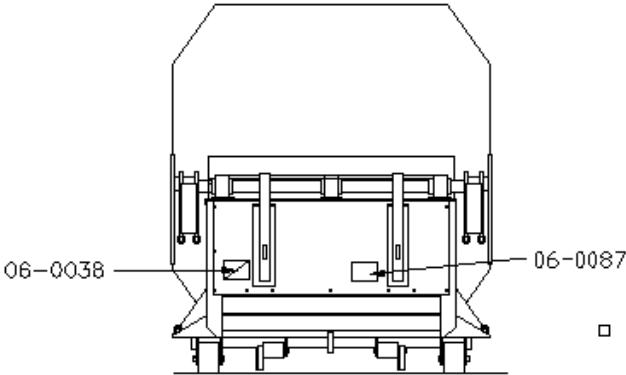

REAR VIEW

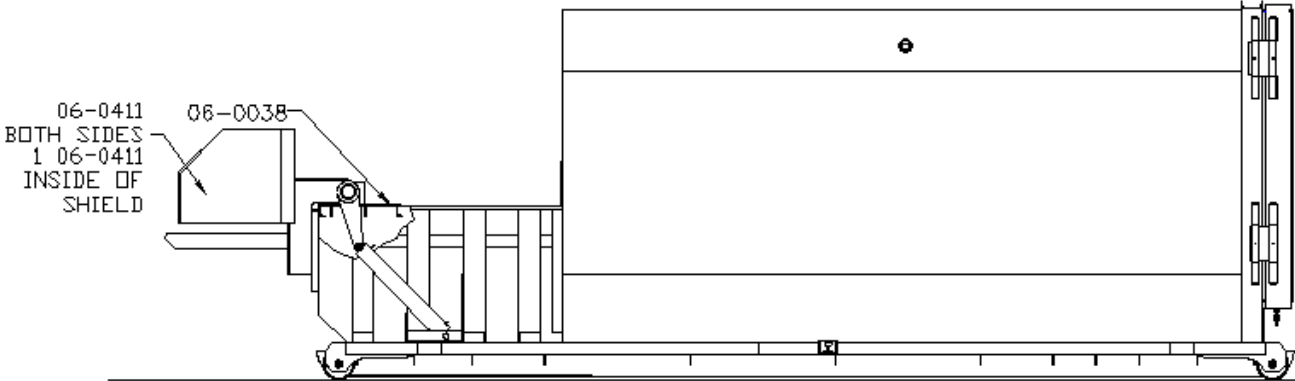

SIDE VIEW

RamJet Self-Contained Compactor Container

INDEX

- A**
auto relatch 43
- C**
circuit breakers 63
concrete pad requirements 21
contact information 20, 28, 52, 76
control panel - models with photoelectric cycle control 34
control panel with integral dumper 32
cylinder parts list 77
cylinder removal instructions 62
- D**
decal care 13
decal images 110
decal parts list 108
decal placement 95
decal placement for integral dumper 116
decals for hydraulic tailgate (HT) units 115
- E**
electrical and hydraulic installation 23
electrical charts 63
electrical parts list 77
electrical schematic 69
electrical symbols 17
- F**
fuses 63
- G**
grease lubrication recommendation 11
guards and access covers 12
- H**
hauler instructions - general 40
hydraulic schematic - typical (Cycon) 70
hydraulic schematic with integral dumper 71
hydraulic symbols 15
hydraulic tailgate operation for optional HT units 45
- I**
integral dumper operation 49
- introduction 4
- L**
liquid removal for optional SL units 48
lock-out/tag-out instructions 7, 53
- M**
maintenance schedule form 57
miscellaneous parts list 77
- O**
operating instructions 31, 33, 36
optional controls 37
- P**
periodic maintenance 55
plc maintenance 67
power unit - standard 5 HP 86
power unit illustration - 10 HP 88
power unit parts list - 10 HP 89, 91
power unit parts list - standard 5 HP 87
preface 5
pre-operation instructions 29
pressure gauge reading for compactor 60
pressure settings 58
principles of operation 62
- R**
ram 78
recommended oils 11
- S**
safety symbols and definitions 6
securing tailgate into chain keeper 41
service/parts assistance 11
specifications 9
standard control panel 30
steel installation procedures 22
system operating characteristics 62
- T**
tailgate 80
tailgate seal replacement 66
tailgate/latch operation 43
through-the-wall power unit installation 25
troubleshooting chart 72

RamJet Self-Contained Compactor Container

INDEX

typical panel box configuration 93

U

understructure, latch 79

W

warning decals on the unit 12

wire sizes 63



www.marathonequipment.com

Customer Care:
800-633-8974

Parts Central:
800-528-5308
www.mecomerchant.com

Technical Service and Warranty:
877-258-1105

Customer Support:

Marathon Equipment Company
P.O. Box 1798
Vernon, AL 35592-1798