

BAYNE THINLINE FOOD SERVICE SERIES LIFTERS

Commercial and Industrial Lifters for Food Service Applications



Innovative. Economical. Efficient.

Bayne® Thinline® has been in business for more than 50 years and is proud of our reputation as a leader in the solid-waste industry. Our proven lines of hydraulic cart lifters are designed, manufactured, and assembled in America at our facility in Fort Payne, AL. This enables Bayne to maintain complete control over the production process, ensuring that you receive a high-quality, reliable product each and every time.

Bayne Thinline Food Service Series Lifters are specifically designed for the food-service industry and are the ideal lifting solution for cafeterias, restaurants, supermarkets, bakeries, commercial kitchens, and more. Sized to fit typical waste containers, these lifters make short work of waste disposal. They are equipped with a chute to prevent spillage, can be fixed or movable, and include fork pockets for easy transport.

Enhance worker safety and minimize back injuries with Bayne Thinline Food Service Series lifters.



Premium Lift Systems

Precision, Quality, and Patented Engineering

For more information: Toll Free: 800-528-5308 | www.baynethinline.com

Bayne Thinline Premium Lift Systems | 4301 Gault Ave. North | Fort Payne, AL 35967

© Copyright 2023 Bayne Thinline All rights reserved



BAYNE THINLINE FOOD SERVICE SERIES LIFTERS

Specifications & Features

Technical Specifications

- Accommodates standard food service type round and rectangular waste containers
- 0-57" dump-over heights
- 40-degree dump angle
- Up to 500 lbs. lift capacity
- 12-second cycle time
- 1,800 psi working pressure
- Standard fork pockets enable easy transportation
- Powder-coated finish for durability
- Available in stationary or mobile application
- Mobile application is available with optional locking casters
- Available with optional 12-volt DC power supply



Fork Pockets Enable Easy Transportation



Optional 12-volt DC Power Supply

Stationary or Mobile (optional locking casters for mobile applications shown)



Premium Lift Systems

Toll Free: 800-528-5308 | www.baynethinline.com

Bayne Thinline Premium Lift Systems | 4301 Gault Ave. North | Fort Payne, AL 35967

© Copyright 2024 Bayne Thinline All rights reserved



BAYNE THINLINE FOOD SERVICE SERIES LIFTERS

Specifications & Dimensions

PERFORMANCE SPECIFICATIONS

Cart Compatibility	Standard Food Service Type Round and Rectangular Waste Containers
Lift Capacity	500 lbs. @ 2,000 psi
Hydraulic Pressure	Working Pressure – 1,500 psi, Maximum Pressure – 2,500 psi
Hydraulic Flow	1.8 gpm
Cycle Time	12 seconds
Finish	Safety yellow powder-coating

LEFT-HAND CONTROL CONFIGURATION (WITH CASTERS)

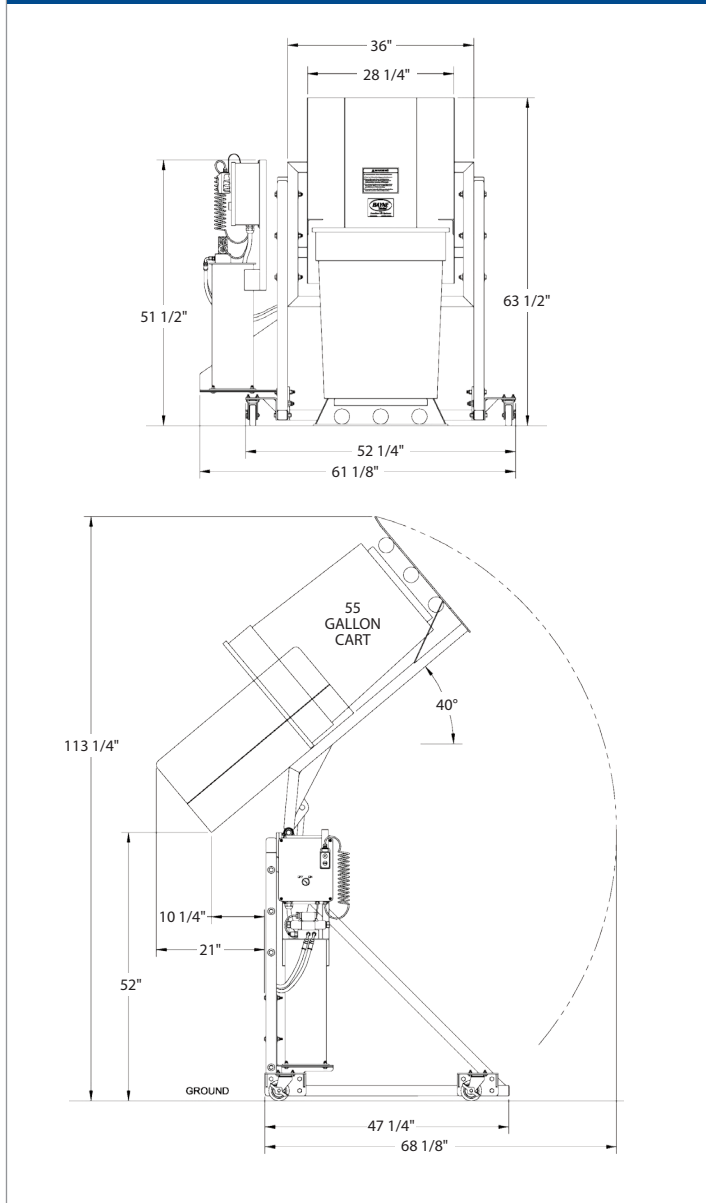

RIGHT-HAND CONTROL CONFIGURATION

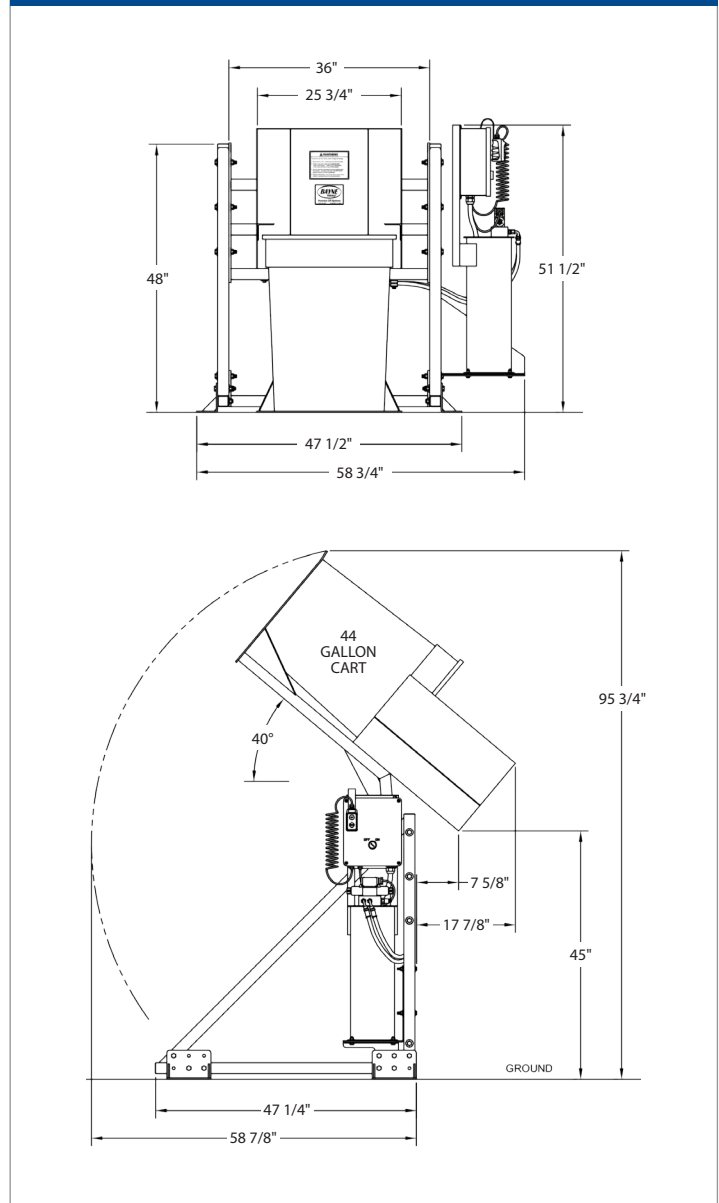

Pictures and mechanical diagrams in this literature are illustrative only and may not be to scale. Specifications are subject to change without notice in order to accommodate improvements to the equipment. Data published herein is for information purposes only and shall not be construed to warrant suitability of the unit for any particular purpose, as performance may vary with the conditions encountered. The only warranty is our standard written Warranty Statement for this product at the time of shipment.



Premium Lift Systems

Toll Free: 800-528-5308 | www.baynethinline.com

Bayne Thinline Premium Lift Systems | 4301 Gault Ave. North | Fort Payne, AL 35967

© Copyright 2023 Bayne Thinline All rights reserved

