



# DURAPACK® 5000

HIGH-COMPACTION REAR LOADER

OPERATION MANUAL

ISSUED NOVEMBER 2024

## **⚠ WARNING**

Failure to follow all instructions and safety precautions in this manual, in the Service Manual, in other manufacturers' manuals and on the safety decals attached to the product could result in serious injury or death to operators or bystanders and/or damage to property.

DO NOT operate this vehicle before you READ and UNDERSTAND this Operation Manual, the Service Manual for this unit, other applicable manufacturers' manuals, and the safety decals on the product.

Each operator of this unit must read and understand all directions in this manual before they first operate this vehicle.

Keep this manual in the cab for new operators and to remind all operators about safe use.





## **READ THIS MANUAL!**

**EVERY PERSON** who will **OPERATE, MAINTAIN, REPAIR, OR OTHERWISE WORK** with the Heil unit **MUST READ AND UNDERSTAND** this entire Operator's Manual before starting the engine or activating any switches or controls. **MAKE SURE** to read the Service Manual for the unit **BEFORE** you do any maintenance or repair procedures.

**ALL USERS** of this equipment must be trained professionals who understand how the machine operates and know how to avoid the risks associated with driving the vehicle and with picking up, compacting, and dumping refuse in an ever-changing traffic environment.

If you do not understand an operation or instruction, seek additional help or instruction from a qualified source **BEFORE** you operate the unit.

# TABLE OF CONTENTS

## Introduction

Section Preview .....	4
How to Use This Manual .....	5
To the Owner .....	6
To the Operator .....	7
To the Operator (Continued) / To the Mechanic .....	8
To the Mechanic (Continued) .....	9
Warranty Claims and Inquiries .....	10
Customer Service and Repair Parts Contact Information .....	11
Models .....	12
Serial Plate Locations .....	13
Reading the Serial Plate .....	14
Product Nomenclature .....	15
Product Nomenclature (Continued) .....	16
Product Nomenclature (Continued) .....	17
Glossary .....	24

## Safety Messages and Decals

Section Preview .....	30
Precautionary Statements .....	31
General Safety Precautions .....	32
General Safety Precautions (Continued) .....	33
Decals .....	36
Decal Placement .....	37
Decal Images .....	43
Reflective Safety Materials .....	55
Care of Decals .....	56

## Lock-Out/Tag-Out Procedure

Section Preview .....	60
-----------------------	----

# TABLE OF CONTENTS

Locking Out the Unit .....	61
<b>In-Cab Display and Controls</b>	
Section Preview .....	66
Controls / In-Cab Display .....	67
Home Screen .....	68
Home Screen (Continued) .....	69
Home Screen (Continued) .....	70
Home Screen (Continued) .....	71
Home Screen (Continued) .....	72
Home Screen (Continued) .....	73
Counter Screen .....	74
Diagnostic, Maintenance, and Option Configuration Screens .....	75
Standard Outside Controls .....	76
Standard Outside Controls (Continued) .....	77
Standard Outside Controls (Continued) .....	78
Standard Outside Controls (Continued) .....	79
Standard Outside Controls (Continued) .....	80
Standard Outside Controls (Continued) .....	81
Standard Outside Controls (Continued) .....	82
Optional Outside Controls .....	83
Optional Outside Controls (Continued) .....	84
Optional Outside Controls (Continued) .....	85
Optional Outside Controls (Continued) .....	86
Optional Outside Controls (Continued) .....	87
<b>Body and Tailgate Props</b>	
Section Preview .....	90
Factory Body Props / Propping the Tailgate .....	91
Propping the Tailgate (Continued) .....	92

# TABLE OF CONTENTS

## Daily Checklist

Body Daily Checklist .....	94
Refuse Vehicle Daily Inspection .....	96
Daily Checks and Inspections .....	97

## Before Going on Route

Section Preview .....	108
Battery Disconnect Switch / Daily Checklist .....	109
Before Starting a Route / Warming up the Hydraulic Oil .....	110
Check the Hydraulic Oil Level .....	111
Hydraulic Oil Tank with Sight Gauge .....	112
Cycle All Hydraulic Functions .....	113
Check the Traveling or "In-transit" Position .....	114
Check the Traveling or "In-transit" Position (Continued) .....	115

## On-Route Operation Procedures

Section Preview .....	118
Driving to Pick-up Locations .....	119
Before Loading .....	120
Loading Refuse Manually .....	121
Loading Refuse Manually (Continued) .....	122
Loading Refuse with a Reeving Mechanism .....	123
Loading Refuse with a Reeving Mechanism (Continued) .....	124
Loading Refuse with a Reeving Mechanism (Continued) .....	125
Loading Refuse with a Reeving Mechanism (Continued) .....	126
Loading Refuse with a Reeving Mechanism (Continued) .....	127
Loading Refuse with a Winch .....	128
Loading Refuse with a Winch (Continued) .....	129
Loading Refuse with a Winch (Continued) .....	130
Loading Refuse with a Winch (Continued) .....	131

# TABLE OF CONTENTS

Loading Refuse with an Arm Mechanism .....	132
Loading Refuse with an Arm Mechanism (Continued) .....	133
Loading Refuse with an Arm Mechanism (Continued) .....	134
Loading Refuse with an Arm Mechanism (Continued) .....	135
Loading Refuse with a Roll Bar Mechanism .....	136
Loading Refuse with a Roll Bar Mechanism (Continued) .....	137
Loading Refuse with a Roll Bar Mechanism (Continued) .....	138
Loading Refuse with a Roll Bar Mechanism (Continued) .....	139
Loading Refuse with a Cart Tipper .....	140
Loading Refuse with a Cart Tipper (Continued) .....	141
Loading Refuse with a Cart Tipper (Continued) .....	142
Loading Refuse with a Cart Tipper (Continued) / Using a Latch Bar .....	143
Using a Latch Bar (Continued) .....	144
Packing On-The-Move .....	145
Leaving the Route for the Landfill/Transfer Station .....	146
<b>Landfill/Transfer Station/Recycle Center Procedures</b>	
Section Preview .....	148
Overview of Landfill / Transfer Station / Recycle Center Procedures .....	149
Unlocking and Raising the Tailgate / Unloading Refuse .....	150
Unloading Refuse / Clean and Inspect the Tailgate .....	151
Lower the Tailgate .....	152
Locking the Tailgate .....	153
Unloading Refuse (Continued) .....	154
<b>End of Day Procedures</b>	
Section Preview .....	156
Parking the Unit .....	157
<b>Preventive Maintenance Chart</b>	
Body Preventive Maintenance Chart .....	160

# TABLE OF CONTENTS

## Lubrication Guide

Body Lubrication Guide .....	164
Body Lubrication Guide (Continued) .....	165

## Compressed Natural Gas (CNG) Option

Important Safety Information .....	168
Important Safety Information (Continued) .....	169
Important Safety Information (Continued) .....	170
Properties of Natural Gas / Signs of a Fuel Leak .....	171
CNG Fuel System Functions and Components .....	172
CNG Fuel System Components (Continued) .....	173
CNG Fuel System Components (Continued) .....	174
CNG Fuel System Components (Continued) .....	175
Fuel System Shut Down Procedure .....	176
CNG Vehicle Operator Emergency Response (Continued) .....	177
Starting Vehicle / Fueling Procedure .....	178
Fueling Procedure (Continued) .....	179
Fueling Procedure (Continued) .....	180
Fueling Procedure (Continued) / Transfer Fueling (Defueling) Procedures .....	181
CNG Fuel System Maintenance .....	182
Maintenance Part Numbers .....	183
Depressurizing/Re-Pressurizing Procedure .....	184
High Pressure Filter .....	185
Welding and Hot Work Procedures .....	186
Lifting the Vehicle / Towing the Vehicle .....	187
CNG Fuel System Inspections .....	188
Inspection/Preventive Care Schedule / Preparation Before Maintenance .....	189
Daily CNG Fuel System Inspection .....	190
CNG Fuel System Troubleshooting .....	191

# TABLE OF CONTENTS

CNG Fuel System Troubleshooting (Continued) .....	192
CNG Fuel System Troubleshooting (Continued) .....	193
CNG Fuel System Troubleshooting (Continued) .....	194
CNG Fuel System Troubleshooting (Continued) .....	195
Heil CNrG Solenoid System Option .....	196
Heil CNrG Solenoid System Option (Continued) .....	197
Heil CNrG Solenoid System Option (Continued) .....	198
Heil CNrG Solenoid System Option (Continued) .....	199
Heil CNrG Solenoid System Option (Continued) .....	200
Heil CNrG Solenoid System Option (Continued) .....	201
Heil CNrG Solenoid System Option (Continued) .....	202
Heil CNrG Solenoid System Option (Continued) .....	203
Heil CNrG Solenoid System Option (Continued) .....	204
Heil CNrG Solenoid System Option (Continued) .....	205
<b>Index</b> .....	<b>207</b>

**DURAPACK 5000**

1

**DURAPACK® 5000**  
**HIGH-COMPACTION REAR LOADER**

**OPERATION MANUAL**  
**ISSUED NOVEMBER 2024**  
**TP1DP5-OM-1124**

# DURAPACK 5000

**NOTES:**

**SECTION 1  
INTRODUCTION**

## PREVIEW

Read this section to learn about:

- The responsibilities of the owner, the operator, and the mechanic
- Warranty information
- Telephone numbers and website URL for parts, technical support, warranty claims, training and manuals
- Identifying the different models
- Identifying the left (street side) of the unit
- The unit serial plate
- Various parts of the unit

## HOW TO USE THIS MANUAL

### Product Variance

This manual may cover options not included on your unit. Also, the location and appearance of the controls on your unit may be different than those shown in this manual. Make sure you know the location of the controls and how to properly operate the controls on your unit before operation.

### Manual Sections

This manual is divided into thirteen (13) sections.

1. Introduction
2. Safety Messages and Decals
3. Lock-Out/Tag-Out Procedures
4. In-Cab Display and Controls
5. Body and Tailgate Props
6. Daily Checklist
7. Before Going on Route
8. On-Route Operation Procedures
9. Landfill/Transfer Station/Recycle Center Procedures
10. End of Day Procedures
11. Preventive Maintenance Chart
12. Lubrication Guide
13. Compressed Natural Gas (CNG) Options

### Terminology

This manual uses terminology that is defined in the **Glossary** which is in Section 1, Introduction.

### Directives

When we give directions for using the equipment, we capitalize key words. These words are usually a command followed by a result.

For example, “MOVE the body eject switch to PUSH ...”.

### Use of **Bold** and CAPITAL Letters

We also put some words in **BOLD AND CAPS** for emphasis, usually related to safety or something of other importance, such as “**MAKE SURE** you close the side doors”.

We put some words in just bold for emphasis, such as “All warranty repairs **must** be performed by ...”.

Each DANGER, WARNING, and CAUTION notice precedes its applicable text.

## TO THE OWNER

This manual is designed to help ensure safe, efficient and proper operation of The Heil Co. d/b/a Heil Environmental ("Heil") DuraPack 5000 Rear Loader refuse collection vehicle (or the unit).

The manual will familiarize you with the unit and will give you proper operating procedures and tips.

For chassis operation and maintenance instructions, see the Chassis Owner's Manual and the DuraPack 5000 Service Manual.

As the owner, you have several responsibilities:

- You must complete and return the warranty registration for the unit to Heil.
- You must make sure that each operator has the proper driver's license.
- You must make sure that the operator does not operate the unit under the influence of drugs or alcohol.
- You must make sure that the unit is properly maintained to meet all local, state and federal requirements along with FMCSA (Federal Motor Carrier Safety Administration) and DOT (Department of Transportation) .
- You must keep the vehicle maintained and properly adjusted to meet the manufacturer's standards and recommendations.

- You must keep accurate records of daily inspections, breakdowns, malfunctions, maintenance and repairs of the unit.
- You must make sure that repairs are made that may affect the safe operation of the unit before it is made available for operation.
- You must provide adequate lighting on the unit for safe operation under low light or night conditions.
- You must provide adequate training for each operator and mechanic that will operate the unit BEFORE an operator goes on route or BEFORE a mechanic performs maintenance or repair procedures.
- You must determine if an operator or mechanic has difficulties reading or understanding this manual. When a person has difficulties reading or understanding this manual, you must provide adequate assistance so that the person does understand the material in this manual.
- You must make sure that each operator uses the equipment on a route as given in the instructions of this manual and other manufacturers' manuals.
- You must provide on-going training for each operator and mechanic that operates the unit.
- You must make sure that this manual stays with the vehicle at all times.

Properly operated and maintained, your DuraPack 5000 unit should give you years of low-cost, trouble free service.

## TO THE OPERATOR

### **DANGER**

Do not operate the unit or perform repair or maintenance procedures on the unit until you read and understand all of the instructions in this manual. Failure to do so may result in injury or death to operators or bystanders.

### **NOTICE**

For Compressed Natural Gas (CNG) units, this Operation Manual should be used in conjunction with any associated CNG System Manufacturer's Operation and Maintenance Manuals. Always read and understand all associated manuals alongside the Heil Parts and Service Manual and Heil Operation Manual.

As the operator of the unit, you have several responsibilities:

- You must have a valid driver's license.
- You must understand and follow all manufacturers' instructions for equipment operation.
- You must observe pertinent laws and regulations.
- Do not use drugs or alcohol while you operate the unit.

- You must read, study and understand all procedures and requirements of this Operation Manual before you operate the unit for the first time. If you do not understand or have difficulty reading this manual, **YOU MUST** tell the owner or designated person before you operate the unit. **DO NOT** operate the unit until you understand the procedures and requirements of this manual.
- You must receive proper training before you operate (or service and maintain) the unit. If you have not been trained, you must inform the owner.
- You must perform a daily inspection of the unit before you go on route. Refer to the **Daily Checklist** <sup>(93)</sup>.
- You must make sure that all decals and labels are clean and readable.
- You must report to the owner (or the designated person) any and all deficiencies, malfunctions or problems you find during the daily inspection.
- You must read, understand and obey all safety messages and decals that are on the outside or in the cab of the unit.

## TO THE OPERATOR (CONTINUED)

- Always use your employer's Lock-Out/Tag-Out procedures. If your employer does not have Lock-Out/Tag-Out procedures, use the **Lock-Out/Tag-Out Procedure** <sup>(59)</sup> in this manual.
- Before you start the engine or operate the unit for the first time
  - You must clear the area of other people.
  - You must learn and practice safe use of all controls and indicators before you operate the unit in a collection route environment or before you do repair or maintenance procedures.
- Before each time you start the engine or operate the unit, you must clear the area of other people.
- Before you operate the unit in reverse, you must make sure the area behind the unit is clear of other people, vehicles or other obstructions.
- You must make sure the unit is on hard, stable ground when you unload refuse at the landfill or transfer station.

## TO THE MECHANIC

### **WARNING**

---

Do not operate the unit or perform repair or maintenance procedures on the unit until you read and understand all of the instructions in this manual. Failure to do so may result in injury or death to operators or bystanders and/or damage to the unit or other property.

---

### **WARNING**

---

A unit that needs service or repair can malfunction and create a dangerous condition. A part failure during operation can cause serious injury or death to a person or damage to the unit. Repair or replace any failed or defective part immediately.

---

### **NOTICE**

---

If you do not understand a procedure or instruction, tell the owner or the designated person immediately. Do not operate the unit if you do not understand all procedures and instructions in this manual. The owner or designated person can contact your Heil dealer or Heil for additional help. See **Customer Service and Repair Parts Contact Information** <sup>(11)</sup>.

---

## TO THE MECHANIC (CONTINUED)

As the mechanic of the unit, you have several responsibilities:

- You must have a valid driver's license if you operate the unit on a public road.
- You must understand and follow all manufacturers' instructions for equipment operation.
- You must observe pertinent laws and regulations.
- Do not use drugs or alcohol while you service or operate the unit.
- You must read, study and understand all procedures and requirements of this Operation Manual and the Service Manual before you operate the unit for the first time.
- If you do not understand or have difficulty reading this manual or the Service Manual, you must tell the owner or designated person before you operate or service the unit.
- DO NOT operate or service the unit until you understand the procedures and requirements of this manual and the Service Manual.
- You must receive proper training before you operate or service and maintain the unit. If you have not been trained, you must inform the owner.

- You must read, understand, and obey all safety messages and decals that are on the outside or in the cab of the unit.
- Always use your employer's Lock-Out/Tag-Out procedures. If your employer does not have Lock-Out/Tag-Out procedures, use the **Lock-Out/Tag-Out Procedure**  in this manual.
- Before you start the engine or operate the unit for the first time:
  - You must clear the area of other people
  - You must learn and practice safe use of all controls and indicators before you operate the unit or before you do repair or maintenance procedures.
- Before you operate the unit in reverse, you must make sure the area behind the unit is clear of other people, vehicles or other obstructions.

### **WARNING**

A unit that needs service or repair can malfunction and create a dangerous condition. A part failure during operation can cause serious injury or death to a person or damage to the unit. Repair or replace any failed or defective part immediately.

## WARRANTY CLAIMS AND INQUIRIES

The HEIL ENVIRONMENTAL WARRANTY STATEMENT is printed on the inside, back cover of this manual. Should a failure occur that is covered by this warranty, contact the nearest Heil dealer for warranty repair unless otherwise authorized by Heil.

For all parts, warranty claims, and inquiries, please give the dealer or service center the unit's model and serial number located on the body serial plate. See **Serial Plate Location page** <sup>13</sup> for the location of the body serial plate.

## CONTACT INFORMATION

### **Customer Care**

Phone: 866-275-4345

### **Technical Service**

Phone: 866-310-4345

### **Parts Central**

Phone: 800-528-5308

4301 Gault Avenue North  
Fort Payne, AL 35967  
[www.heil.com](http://www.heil.com)

# DURAPACK 5000

## MODELS

The DuraPack 5000 is a Rear End Loader (REL) and has one body model, the eject model. See the figure below.

The sweep and upper panel open the hopper for loading refuse into the hopper, sweep the refuse into the body and compacts the refuse.

The unit has an eject mode for pushing the refuse from the body. You remove the refuse from the body by raising the tailgate and then operating the ejector panel which pushes the refuse from the body.



**Figure 1. Eject Model**

# DURAPACK 5000

## SERIAL PLATE LOCATIONS

You determine the sides of the unit by facing the direction of forward travel. The left side is the “streetside” and the right side is the “curbside”. The figure below shows the locations of the serial plates on the street side of the unit’s body and tailgate. See the next page for a description of the information that is on the serial plate.



BODY SERIAL PLATE LOCATION



TAILGATE SERIAL PLATE LOCATION

Figure 2. Serial Plate Locations

# DURAPACK 5000

## READING THE SERIAL PLATE

The serial plate is the “birth certificate” of the unit. See the figure below.

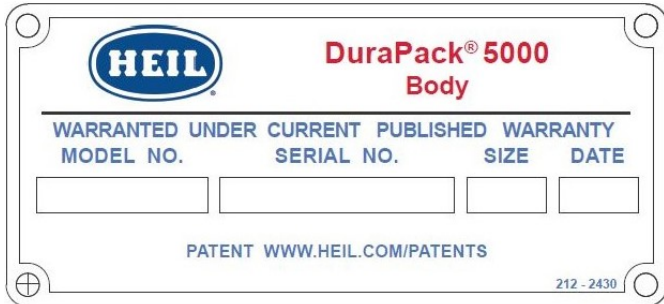

**Figure 3. Reading the Serial Plates**

Information stamped in the boxes on the serial plate indicates:

Model number:

6'12-nnnn (“n” is any single-digit number)

Unit’s unique serial number

Body size (cu. yd.)

Date of manufacture (last number of the year followed by the number of the day of the year, e.g. J078 is year 2018 and the 78th day of 2018).

## NOTICE

The code for the year of manufacture is in accordance with FMVSS 115. See the following table.

Year of Manufacture			
Year Code	Year	Year Code	Year
J	2018	W	2028
K	2019	X	2029
L	2020	Y	2030
M	2021	1	2031
N	2022	2	2032
P	2023	3	2033
R	2024	4	2034
S	2025	5	2035
T	2026	6	2036
V	2027	7	2037

## PRODUCT NOMENCLATURE

The figure below shows the major components and their typical location on the unit. See the following pages for brief descriptions of each component shown below.



**Figure 4. Product Nomenclature (1 of 2)**

# DURAPACK 5000

## PRODUCT NOMENCLATURE (CONTINUED)

The figure below shows the major components and their typical location on the unit. See the following pages for brief descriptions of each component shown below.

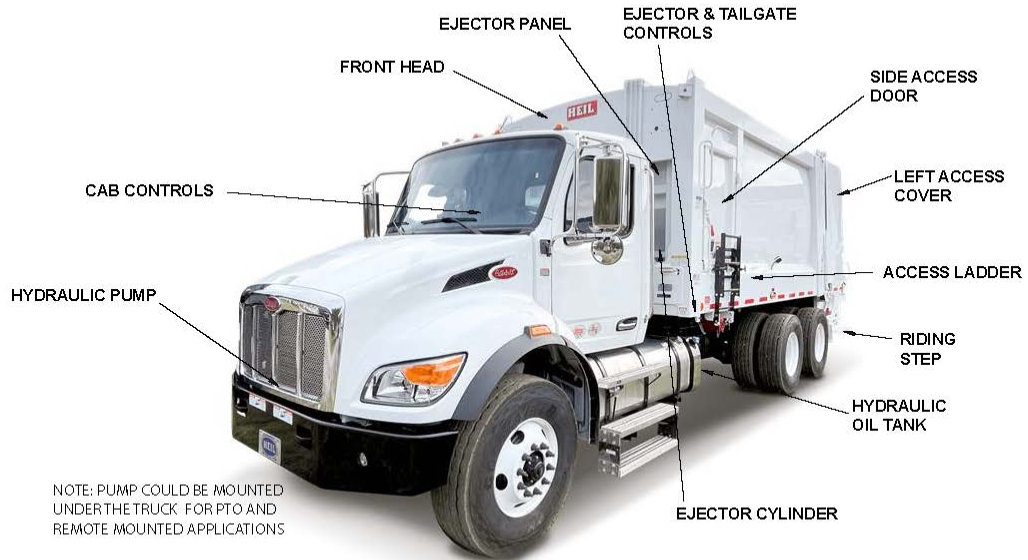

Figure 5. Product Nomenclature (2 of 2)

## PRODUCT NOMENCLATURE (CONTINUED)

### **DANGER**

---

Do not use an arm mechanism or roll bar as a riding step. Obey safety messages and use the riding step for when traveling on the unit. Serious injury or death may occur.

---

**Arm Mechanism** – This option allows an operator to load refuse from a commercial refuse container into the hopper with the assist of an arm mechanism. After the operator secures the refuse container with notches in the arm mechanism, the operator secures the refuse container with the latch bar and uses the controls to lift the refuse container with the arm mechanism and tilt the container which dumps the refuse into the hopper. The operator then lowers the container to the ground with the arm mechanism.

### **DANGER**

---

Make sure the unit is in the Lock-Out/Tag-Out mode before you enter the body. When the unit is not in the Lock-Out/Tag-Out mode and a person is in the body, the packer/ejector panel and/or diverter panels can be operated. Serious injury or death may occur if the packer/ejector panel moves while a person is in the body.

---

### **DANGER**

---

When necessary and available, use the side door for entry to the body. When there is no side door, use the front head for entry to the body. Make sure the unit is in the lock-out mode before you enter the body. When the unit is not in the lock-out mode and a person is in the body, the ejector panel, slide assembly or packer panel can be operated. Serious injury or death may occur if the ejector panel, slide assembly or packer panel moves while a person is in the body.

---

**Body** – The body stores the compacted refuse until you dump the refuse at the landfill. **DO NOT** enter the body from the hopper. Use the space available at the front head or, if equipped, the side access door. Do not store refuse in the body overnight.

**Cart Tipper** – One or more optional cart tippers can be located on the tailgate assembly. An operator uses a cart tipper to raise and dump a residential refuse container. The controls will be located on the rear, curb side of the unit.

## PRODUCT NOMENCLATURE (CONTINUED)

### **DANGER**

---

Do not use an arm mechanism or roll bar as a riding step. Obey safety messages and use the riding step for when traveling on the unit. Serious injury or death may occur.

---

**Comb Lift** and **Arm Mechanism** options allow operators to lift compatible waste containers and empty them into the hopper. When using either of these optional devices the movement is controlled at the rear of the tailgate using a sustained pressure control. Operators must ensure that nearby personnel are clear of the area around the movement of the lifting mechanism. The area directly behind the containers must also be clear in the event of the loss of the container during the lifting operation. Only containers that are in good condition should be used with a lifting device to prevent them from dislodging from the lifting device. The tailgate mechanics should not be operated while the container and the mechanism are in the raised position to prevent potential impact of the packing mechanism to the container.

### **DANGER**

---

Stand clear when the ejector panel is in motion. Keep side access door closed when ejector panel is in motion. Failure to obey may result in severe injury or death.

---

### **NOTICE**

---

Do not use the ejector panel to pack refuse against a closed tailgate (backpack). Packing refuse against a closed tailgate may result in damage to body or ejector cylinder.

---

**Ejector Panel & Cylinders** – The ejector panel and cylinders push the refuse out of the body when the tailgate is OPEN.

**Ejector & Tailgate Controls** – These controls are located in the cab of the unit and allow an operator to OPEN the tailgate and fully EXTEND the ejector panel, which pushes the refuse out of the unit. The operator then uses the controls to RETRACT the ejector panel and CLOSE the tailgate.

**Front Head** – The open area at the front of the body. You can see the ejector panel from the cab through the front head. Use

## PRODUCT NOMENCLATURE (CONTINUED)

this opening to access the body, **ESPECIALLY** when the unit does not have the optional side access door.

### **WARNING**

---

**BE CAREFUL** at all times when you use the ladder rungs and grab handles. Maintain good balance with two feet and one hand, or one foot and two hands, firmly in place.

---

**Grab Handles** – The grab handles are on the street and curb sides of the tailgate. You use the grab handles to help stabilize you when you use the riding step.

### **DANGER**

---

Do not enter the hopper unless the unit is in the Lock-Out/Tag-Out mode. When the unit is not in the Lock-Out/Tag-Out mode and a person is in the hopper, the packer/ejector panel can be operated. **DEATH** or **SERIOUS INJURY** may occur if the packer/ejector panel moves while a person is in the hopper.

---

**Hopper** – The hopper is the refuse loading chamber of the tailgate. **NEVER** use the hopper as an entrance to the body.

**Hopper Sill** – A lip on the hopper over which you dump the refuse into the hopper. The lip provides a resting spot for manual loading of residential refuse containers. **NEVER** climb or stand on the hopper sill.

**Hydraulic Oil Tank** – The tank is the reservoir for the hydraulic oil which operates all hydraulic cylinders described above.

### **WARNING**

---

Operating the unit's controls with a suspended load, such as a raised tailgate or a container on a lift mechanism, will allow the load to move even when the hydraulic pump is **OFF**.

---

## PRODUCT NOMENCLATURE (CONTINUED)

**Hydraulic Pump** – The unit's hydraulic pump provides the oil flow for the hydraulic system. It is located either in front of the unit's engine or underneath the unit, powered by the transmission through a Power Take-Off (PTO). With a front-mount pump, the operator turns the pump ON and OFF as needed with the SYSTEM POWER button located on the in-cab display. With a PTO pump, the operator engages the PTO then turns the SYSTEM POWER switch ON to activate the pump. Depending on the pump and PTO combination, hydraulic oil may flow through the system when the pump is off, however, the operator controls are inoperative and the system hydraulic oil pressure is not sufficient to operate the unit's functions.

**In-Cab Display** – The InSight™ Diagnostic Display is used to operate the pump and throttle advance, and optional filter bypassed indicator and strobe lights; has display indicators for the pump and tailgate; has a message banner that displays critical faults, operator warnings, communication failures and other operational information. See **Controls / In-Cab Display** [67].

**Latch Bar** – The latch bar provides a means of securing a refuse container for lifting and tilting with a reeving mechanism, a winch or, a roll bar.

### **DANGER**

---

The packer panel and slide assembly are dangerous. They can cause serious injury or death if a person is inside the hopper. Make sure no one is inside the hopper before you begin a packer function. Put the unit in the Lock-Out/Tag-Out mode if a person must enter the hopper.

---

**(Sweep) Panel** – You MOVE the sweep panel UP while you move the slide assembly OUT to load refuse into the hopper. You MOVE the sweep panel DOWN while you move the slide assembly IN to sweep refuse from the hopper towards the body.

**Sweep Panel** – The packer panel is comprised of the sweep and upper panel (and other parts). The packer panel opens to load refuse into the hopper, moves refuse from the hopper into the body and compacts it.

**Reeving Mechanism** – The reeving mechanism is an assembly that includes a cylinder, an attached cable with hook and controls. This option allows an operator to load refuse from a commercial refuse container into the hopper. The controls will be located on the rear, curb side of the unit.

## PRODUCT NOMENCLATURE (CONTINUED)

### **DANGER**

Do not use an arm mechanism or roll bar as a riding step. Obey safety messages and use the riding step for when traveling on the unit. Serious injury or death may occur.

---

**Roll Bar** – This option allows an operator to load refuse from a commercial refuse container into the hopper with the assist of a roll bar. The operator first secures the refuse container with the latch bar, then uses the controls to lift the refuse container and tilt the container which dumps the refuse into the hopper. The roll bar rests about half way up from the bottom of the refuse container.

### **DANGER**

Use only the riding step provided to travel on the outside of the unit during collection activities. Use hand holds provided and maintain at least 3 points of contact. Failure to obey these instructions can result in serious injury or death.

---

### **WARNING**

Do not use riding step when vehicle speed is more than 10 MPH or to travel more than 2 tenths (0.2) of a mile. Do not use riding step when vehicle operates in reverse. Always face vehicle when using riding step.

---

**Riding Step** – The riding steps are on the street and curb sides of the tailgate. You use the riding step and grab handles when it is necessary to ride on the rear of the unit for short distances while on route. Make sure you use both of the grab handles and the riding step.

**Side Access Door** – The optional side access door is located on the front, street side of the body. Use this door for access to the body for cleaning or other maintenance tasks. **MAKE SURE** the unit is in lock-out condition and the keys are removed from the ignition and in the operator's control **BEFORE** you enter the side door. Always use the step assembly when you use the side access door. **BE CAREFUL** at all times when you use the step assembly. Maintain good balance with at least two feet and one hand, or one foot and two hands, firmly in place at all time.

**Slide (Upper Panel) Assembly** – You move the slide assembly **OUT** while you move the packer panel **UP** to load refuse

## PRODUCT NOMENCLATURE (CONTINUED)

into the hopper. You move the sweep panel IN while you move the packer sweep DOWN to push the refuse into the body.

**Slide/sweep Controls** – The operator uses these controls to operate the slide assembly and the packer panel to open the hopper to load refuse and to move refuse from the hopper into the body.

### **DANGER**

---

A tailgate in motion is dangerous. Serious injury or death may occur if a person is struck by a moving tailgate or becomes trapped between the tailgate and the body. Clear the area near the tailgate of all unnecessary people before you raise or lower the tailgate.

---

**Tailgate** – Raise the tailgate at the landfill or transfer station to unload the refuse.

A RED "TG OPEN" display indicator on the in-cab display lets the operator know when the tailgate is OPEN (UP). A GREEN "TG CLOSED" display indicator on the in-cab display lets the operator know when the tailgate is CLOSED (DOWN).

**Tailgate Left and Right Access Covers** – In normal operation, the tailgate doors protect the operator from various exposed pinch points.

### **DANGER**

---

Always prop a tailgate when you leave it raised for maintenance, service or cleaning procedures. Any part of your body between the unit's body and the tailgate while you prop the tailgate or when the tailgate is propped is dangerous. Serious injury or death may occur if any part of your body is between the tailgate and the body if the tailgate suddenly closes.

---

**Tailgate Props** – Always use both tailgate props, one on each side of the unit, when you raise the tailgate for maintenance or service procedures.

**Tailgate Cylinders** – You use these cylinders to RAISE the tailgate before you unload the compacted refuse at the landfill. After you unload the refuse, you use the cylinders to LOWER the tailgate.

## PRODUCT NOMENCLATURE (CONTINUED)

**Throttle Advance** – There are two standards and an additional switch when there is a lifting option (winch, etc.) installed. The primary switch is in the cab and must be set to ON for the outside switch(es) to operate. The second standard switch is next to the tailgate and ejector panel controls at front, street side of the body. The switch allows the operator to increase the RPMs of the engine which delivers more hydraulic flow for raising the tailgate and extending the ejector panel while pushing refuse out of the body.

A third throttle advance switch is located on the curb side of the tailgate when there is an optional lift device. The operator uses the switch to increase hydraulic flow while raising a commercial refuse container with a winch, reeving mechanism, an arm mechanism or a roll bar.

The throttle advance is automatically engaged during the tailgate packing cycle.

**Winch Assembly** – The winch assembly includes a winch, an attached cable with hook and controls. This option allows an operator to load refuse from a commercial refuse container into the hopper. The controls will be located on the rear, curb side of the unit.

## GLOSSARY

TERM	DEFINITION
accident	An incident that results in unintended harm.
arm mechanism	An option for Rear End Loaders (RELs), an assembly that uses arms that mate with a refuse container's slots to lift, dump and lower a refuse container.
bin	The refuse collection container
sweep	The assembly that moves refuse into the body. The sweep works with the upper panel to open the hopper, move refuse into the body, compact the refuse and to close the hopper.
body	The complete body assembly or the area of the body where the refuse is stored.
cart tipper	A Rear End Loader (REL) option attached to the tailgate that allows an operator to secure a residential refuse container and unload its contents into the hopper
CAUTION	Indicates a hazardous situation which, if not avoided, could result in minor or moderate injury.
collapsed position	The fully retracted position of a cylinder
DANGER	Indicates a hazardous situation which, if not avoided, will result in death or serious injury.
extend/EXTEND	Make a cylinder rod move out its base / Command to move the packer panel towards the body
front head	The part of the body that allows access to the body from the front of the body. This is the ONLY access to the body when the unit does not have an optional side access door.
FULLY RETRACTED POSITION	The packer/extend cylinder is fully retracted and the packer panel is all the way to the front of the hopper. May also be referred to as "Home Position" or "Front Head".
hand holds (grab handles)	An attachment to the tailgate of a Rear End Loader (REL) that an operator grabs with their hands while using the riding step.

## GLOSSARY

<b>TERM</b>	<b>DEFINITION</b>
harm	An action that causes death, injury or property damage
hazard	A potential source of harm
hopper	The loading chamber of the unit in front of the packer panel where you dump the refuse material.
illuminate	Make a lamp shine light (the lamp is on).
IN	Command to move the slide assembly IN
in-cab display	The InSight Diagnostic Display shows the Operator important system information including display indicators, status, critical fault messaging and counter information and allows a qualified and authorized Service Technician to see detailed system information and make configuration changes based on option configuration.
incident	An unintended and undesired event that has the potential to harm
latch bar	The assembly that secures a residential refuse container to the tailgate
LATCHED	The condition when the tailgate is fully CLOSED, thereby locking the tailgate
LOAD POSITION	Applicable to Rear End Loaders (RELs), the packer panel is UP and the slide assembly is OUT. This opens the hopper for loading.
lower/LOWER	Move the lift arms, forks, body or tailgate down. / Command to move the lift arms, forks, body or tailgate down
may	You are allowed to do the action, but it is not mandatory. It is understood to be permissive.
must	The action is mandatory.
NOTICE	Alerts you to practices not related to personal injury, such as damage to the unit or other equipment
off/OFF	When a light is not illuminated / The position of a switch or other control to stop a function.

## GLOSSARY

TERM	DEFINITION
on/ON	When a light or lamp illuminates / The position of a switch or other control to start a function
operator	Any person who uses the unit and its equipment. One who controls the operation of various unit accessories and mechanisms, loads material, performs functions such as operating the loader, cart tipping and packing of wastes or recycled products, and who may also drive the unit along the route during the collection process. The operator may also be the driver.
(sweep) panel	The packer assembly that moves refuse into the body. The sweep works with the slide to close the hopper, to move refuse into the body and to open the hopper
packer panel	The packer panel is comprised of the packer panel and the upper panel. The packer panel moves refuse out of the hopper and compacts it into the body.
PACK POSITION	Applicable to Rear End Loaders (RELs), the packer panel is DOWN and the slide assembly is IN. The operator uses this position, repeated as necessary, to sweep refuse from the hopper and compact the refuse into the body.
PTO	Power Takeoff
raise/RAISE	Move the tailgate up. / Command to move the tailgate up
REL	Rear End Loader
retract/RETRACT	Make a cylinder rod go into its base. / Command to move the packer panel towards the hopper
reeving mechanism	An option for Rear End Loaders (RELs), a cylinder assembly that is located on the centerline of the roof with which an operator can raise and dump a commercial refuse container
riding step	On Rear End Loaders (RELs), the platform at the side of the tailgate that an operator stands on while riding on the outside of the unit during collection activities

## GLOSSARY

TERM	DEFINITION
roll bar assembly	An option for Rear End Loaders (RELs), an assembly that uses a bar to lift, dump and lower a residential refuse bin
RPM	Revolutions Per Minute
should	The action is advised.
side access door	The optional side access door is located on the street side of the unit. This is the preferred access into the body. ALWAYS <b>Lock-Out/Tag-Out</b> the unit BEFORE entering the body.
tailgate access covers	Covers on each side of the tailgate that protect an operator from pinch points during normal operation
throttle advance	On Rear End Loaders (RELs), when the unit is in neutral, you use the throttle advance to increase the RPMs of the engine which results in greater flow of hydraulic fluid for operation of the tailgate, ejector and optional container lifting devices.
unit	The Heil DuraPack 5000 refuse collection vehicle referred to in this manual.
UNLATCHED	The side access door is not closed or secured.
upper panel	The assembly that moves refuse into the body. The upper panel works with the packer panel to open the hopper, move refuse into the body, compact the refuse and to close the hopper.
WARNING	Indicates a hazardous situation, which if not avoided, could result in death or serious injury.
winch	An option for Rear End Loaders (RELs), a mechanism with a hook and cable that an operator uses to raise, dump and lower a commercial refuse container

# DURAPACK 5000

NOTES:

**SECTION 2**  
**SAFETY MESSAGES AND DECALS**

## PREVIEW

Read this section to learn about:

- General safety precautions and safety precautions for the safe operation and maintenance of the unit
- The safety precautions for NOT towing another vehicle or machine
- Safety decals on the unit

## PRECAUTIONARY STATEMENTS

Read this entire manual and especially this safety section before you operate the vehicle. Failure to follow these important precautions could result in serious injury, death, or property damage.

 This safety alert symbol indicates important safety messages in this manual and on safety decals attached to the equipment. Make sure you read all of these messages and follow the instructions and precautions.

In the general text of the manual and in the safety labels attached to the product, signal words indicate the type and seriousness of risk that you could encounter if you do not follow the precautions. The signal words and their definitions follow:

### **DANGER**

---

DANGER indicates a hazardous situation which, if not avoided, WILL result in DEATH or SERIOUS INJURY.

---

### **WARNING**

---

WARNING indicates a hazardous situation which, if not avoided, COULD result in DEATH or SERIOUS INJURY.

---

### **CAUTION**

---

CAUTION indicates a hazardous situation which, if not avoided, COULD result in MINOR or MODERATE INJURY.

---

### **NOTICE**

---

NOTICE addresses practices not related to personal injury, such as property damage or damage to the equipment.

---

The following pages provide a summary of some of the more important safety precautions that are in this manual. There are additional safety precautions in other sections of this manual that are not contained in this section. You must also read, understand and follow those messages.



## GENERAL SAFETY PRECAUTIONS

- **DO NOT** operate the unit under the influence of alcohol or drugs or when extremely tired or when you are not alert, as this may result in an accident that can cause serious injury or death.
- **DO NOT** operate the unit unless you have the proper training and vehicle operator license.
- **ALWAYS** carry and maintain a fire extinguisher and first aid kit in the unit. **MAKE SURE** you know how to use them.
- **CLEAN AS NECESSARY** any safety decals that you cannot read at a safe viewing distance from the hazard because of dirt. If any decals are illegible from damage or wear, **REPLACE** them **IMMEDIATELY**. Get decals from your Heil dealer or Heil.
- **DO NOT** use this refuse collection vehicle to TOW another vehicle or equipment. It **IS NOT DESIGNED** or equipped to tow another vehicle or other equipment. Towing another vehicle or equipment may result in injury or death to the operator or other people or damage to the unit.
- **MAKE SURE** all individuals are clear of any moving parts, mechanisms or components of the unit before you operate the controls.
- **DISENGAGE** the PTO or PUSH the SYSTEM POWER switch so the pump shuts off when you are not using the unit, when you are repairing the unit, when you are working on the unit, or when traveling in the unit for longer than two minutes.
- **ENGAGE** the PTO or PULL the SYSTEM POWER switch **ONLY** when you are on route OR as necessary to perform repairs.
- When the unit is stored or not in use, you **MUST** do the following:
  - SET ALL lift cylinders (including the body raise cylinders) to the collapsed position.
  - For units with manual transmissions, **DISENGAGE** the PTO and PUSH the PUMP switch so it shuts off the pump.
  - For units with automatic transmissions PUSH the SYSTEM POWER switch so the pump shuts off.
  - **REMOVE** the key from the ignition. This helps prevent tampering by unauthorized persons.
  - Refer to **Lock-Out/Tag-Out Procedure** <sup>59</sup>.
- You must be attentive at all times while you operate the controls and be ready to stop or reverse the function if necessary.

## BEFORE OPERATING THE EQUIPMENT

- **DO NOT** operate or service this machine until you are fully trained and have read and understand this entire manual.
- **NEVER** operate the unit **UNLESS** you are fully knowledgeable of all control functions. See the **In-Cab Display and Controls** <sup>65</sup> of this manual.
- **MAKE SURE BEFORE** you operate the vehicle or its controls that all individuals are at a safe distance away from the unit.
- **DO NOT** operate the unit when it needs service or repair.
- **DO A VISUAL CHECK** at the beginning of each shift of the unit and run it through several cycles to find fluid leaks, broken, missing or malfunctioning, and excessively worn components (including hoses). See the **Daily Checklist section** <sup>93</sup> of this manual. If you find leaks, broken, missing or malfunctioning parts, immediately stop and get the condition repaired or serviced.

## USE PERSONAL PROTECTIVE EQUIPMENT

- **ALWAYS WEAR** the proper safety equipment, such as hard hats, safety shoes, protective eye wear, reflective clothing and gloves. Confirm with the owner/operator that you are using proper safety equipment.
- **WEAR PROPER EYE PROTECTION** and avoid contact with oil if possible whenever you work on or about hydraulic lines or components. **NEVER** check for oil leaks with your bare hands.

## BEWARE OF OVERHEAD OBSTRUCTIONS

- **KNOW** the clearance required for **ALL** overhead obstructions (such as viaducts and bridges) that you may encounter when you drive the unit. See the decal in the chassis cab for your unit's overall height.
- **NEVER** drive the unit under any overhead obstruction of unknown height clearance.
- Become familiar with your route. Be aware of all overhead trees and obstructions that could cause problems during refuse collection.
- **CHECK** the height of the unit after you do any modifications to the chassis suspension. Any chassis suspension modification may change the height of the unit. See Tables 1 and 2.

- **LOOK UP AND LIVE. MAKE SURE** there is enough clearance between a lowered or raised container and overhead power lines. It is not necessary for the unit or container to touch the electric cable for the electricity to pass through the unit. See Tables 1 and 2.
- **STAY IN THE CAB** and **KEEP AWAY FROM ALL METAL PARTS OF THE UNIT** if the unit does touch a power line. **STAY IN THE UNIT UNTIL HELP ARRIVES.**

## OVERHEAD CLEARANCES

### NOTICE

Table 1 and 2 is in accordance with OSHA 29CFR 1910.333. (Also refer to ANSI Standard B30.5-2004, 5-3.4.5.) If local rules and laws require more clearance, you must follow those.

**Table 1. Overhead Clearances When Operating the Unit**

<b>Voltage of Electric Line</b>	<b>Minimum Clearance</b>
50,000 or less	10 feet (3 m)
Above 50,000 to 200,000	15 feet (4.6m)
Above 200,000 to 350,000	20 feet (6.1 m)
Above 350,000 to 500,000	25 feet (7.6 m)
Above 500,000 to 750,000	35 feet (10.7 m)
Above 750,000 to 1,000,000	45 feet (13.7 m)

**Table 2. Overhead Clearances When Driving the Unit**

<b>Voltage of Electric Line</b>	<b>Minimum Clearance</b>
750 or less	4 feet (1.2 m)
Above 750 to 50,000	6 feet (1.8 m)
Above 50,000 to 345,000	10 feet (3 m)

**Table 2. Overhead Clearances When Driving the Unit**

Voltage of Electric Line	Minimum Clearance
Above 345,000 to 750,000	16 feet (4.9 m)
Above 750,000 to 1,000,000	20 feet (6.1 m)

## **LOADING REFUSE INTO THE UNIT**

- **YOU MUST BE ATTENTIVE** at all times when you load refuse and be ready to stop or reverse the function in use if necessary.
- **ALL PERSONS MUST STAND CLEAR** when the tailgate is in motion and during the unloading cycle. **MAKE SURE** no one stands under or crosses under a raised tailgate.
- **LOOK UP AND LIVE.** Make sure there is enough clearance between a raised container and overhead power lines. Refer to Tables 1 and 2.

## **UNLOADING**

- **MAKE SURE** the unloading area is clear of all personnel.
- **ALL PERSONS MUST STAND CLEAR** when the tailgate is in motion and during the unloading cycle. **MAKE SURE** no one stands under or crosses under a raised tailgate.

## **TOWING OF ANY EQUIPMENT**

- Heil **DOES NOT** recommend that you tow any kind of equipment with the unit. The unit was **NOT DESIGNED** nor intended for towing.

## DECALS

The following pages show the DANGER, WARNING and CAUTION decals and list the reflective safety materials that are on the vehicle. See the Parts and Service Manual for the location and part numbers of all decals on the unit.

### NOTICE

---

Replace any decal with a new decal if the old decal is lost, destroyed, painted over or cannot be read. When you replace a part that had decals, make sure you install new decals on each new part. Decal part numbers can be found below and in the Parts Manual. You can purchase replacement decals from your **Heil Dealer** or from the **Heil Parts Central, 800-528-5308**.

---

## REFLECTIVE SAFETY MATERIALS

See the Parts and Service Manual for the location and part numbers of the reflective safety materials on the unit.

### NOTICE

---

Replace any safety material with new safety material if the old safety material is lost, destroyed, painted over or cannot be seen. When you replace a part that had safety material on it, make sure you install new safety material on the new replacement part. See the Parts and Service Manual for all part numbers and location of the safety materials.

You can purchase replacement decals from your **Heil Dealer** or from the **Heil Parts Central, 800-528-5308**.

---

# DURAPACK 5000

## DECAL PLACEMENT

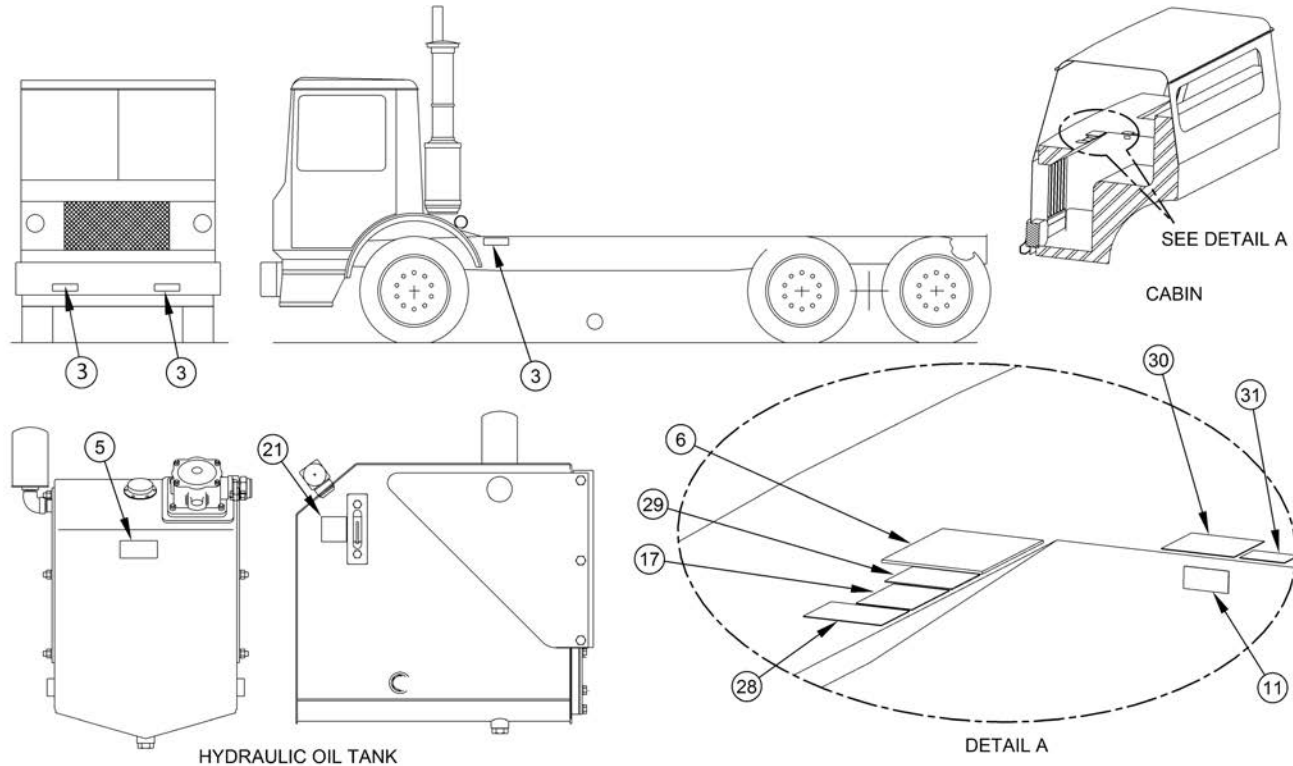

SHEET 1 OF 4

# DURAPACK 5000

## DECAL PLACEMENT (CONTINUED)

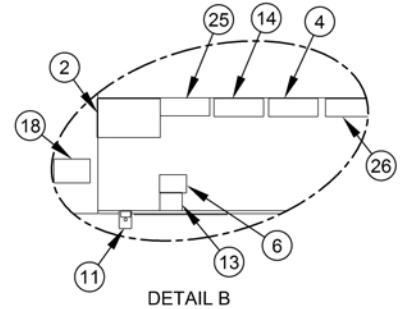
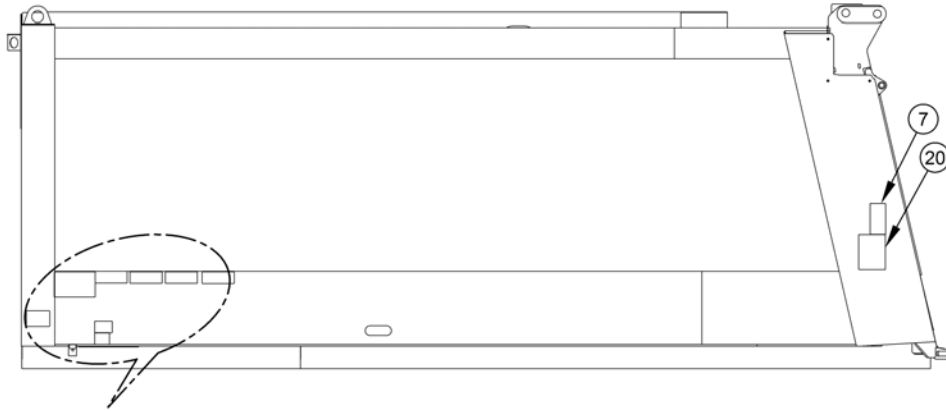
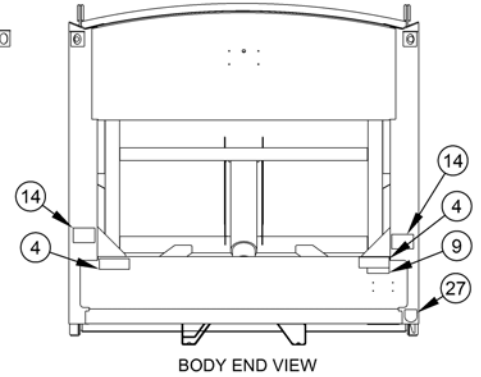
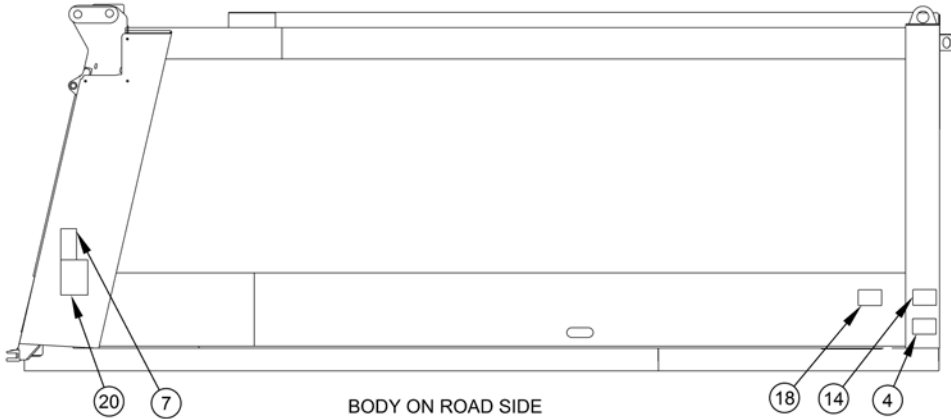

SEE DETAIL B

BODY OFF ROAD SIDE

SHEET 2 OF 4

# DURAPACK 5000

## DECAL PLACEMENT (CONTINUED)

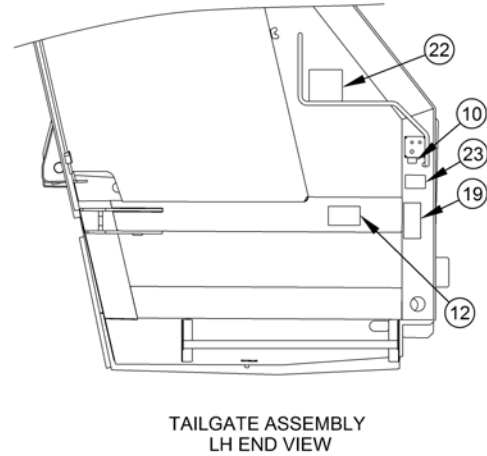
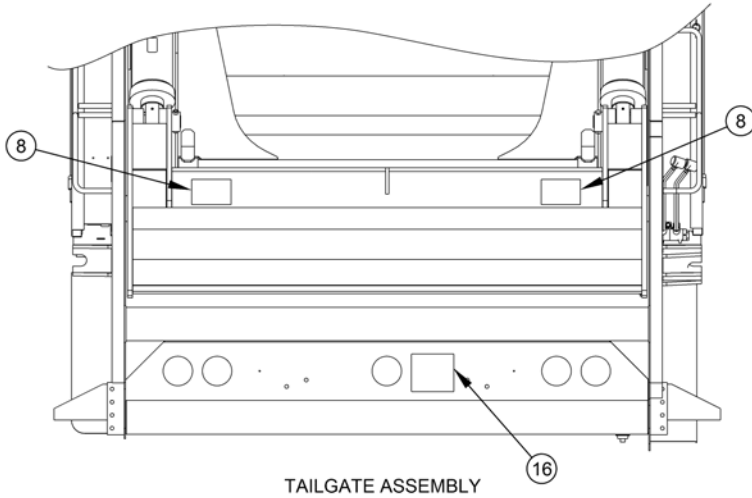

SHEET 3 OF 4

## DECAL PLACEMENT (CONTINUED)

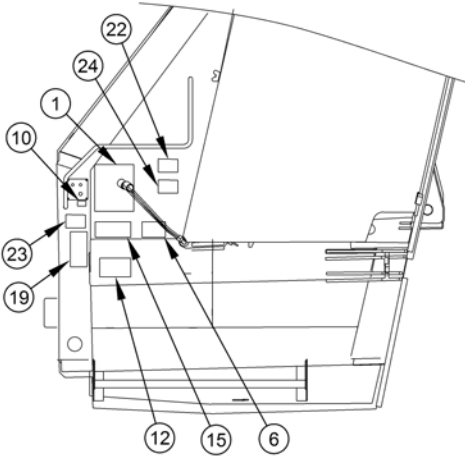

TAILGATE ASSEMBLY  
RH END VIEW

SHEET 4 OF 4

# DURAPACK 5000

## DECAL PLACEMENT (CONTINUED)

ITEM	PART NO.	DESCRIPTION	EFF	QTY
-	212-1579	KIT, Decal, Std. ....	-	REF
1	212-1541	DECAL, Tailgate Controls .....	-	1
2	212-1542	DECAL, Lubrication Guide .....	-	1
3	212-1764	DECAL, Danger, Under Chassis, Stop Engine .....	-	3
4	212-1781	DECAL, Caution, Enter Body, Stop Engine .....	-	3
5	212-1782	DECAL, Hydraulic Oil Only .....	-	1
6	212-1783	DECAL, Warning, Operator's Manual .....	-	1
7	212-1801	DECAL, Danger, Stand Clear When Tailgate Raise .....	-	2
8	212-1802	DECAL, Danger, Stand Clear When sweep Panel in Motion .....	-	2
9	212-1841	DECAL, Safety Requirements, ANSI .....	-	1
10	212-1903	DECAL, Buzzer .....	-	2
11	212-1904	DECAL, Throttle Advance, Accelerator .....	-	1
12	212-1905	DECAL, Caution, Riding Step .....	-	2
13	212-1906	DECAL, Slide panel, Tailgate Ejector .....	-	1
14	212-1911	DECAL, Caution, Stand Clear When Panel in Motion .....	-	2
15	212-1969	DECAL, sweep .....	-	1
16	212-1821	DECAL, Danger, Not Designed for Towing .....	-	1
17	212-1902	DECAL, Caution, Do Not Use Riding Step .....	-	1
18	212-2689	DECAL, Flag, Made in the USA .....	-	2
19	212-2691	DECAL, Cross Behind .....	-	2
20	212-2791	DECAL, Caution, Tailgate Prop Operation .....	-	2
21	212-2275	DECAL, Oil Level .....	-	1
22	212-1899	DECAL, Danger, Stay Clear When Container Off the Ground .....	-	2
23	212-1838	DECAL, Container, Dump .....	-	2
24	212-1839	DECAL, Winch Mechanism .....	-	1
25	212-1907	DECAL, Danger, Access Door Closed .....	-	1
26	212-1780	DECAL, Caution, Side Door .....	-	1
27	212-1915	DECAL, Information-Heil Replacement Parts .....	-	1
28	212-1909	DECAL, Warning, Overall Height .....	-	1
29	212-1918	DECAL, Safety Instructions, Back-Up Alarm .....	-	1

# DURAPACK 5000

30	212-1968	DECAL, Caution, Disengage PTO .....	- .....	1
31	212-1970	DECAL, Tailgate Raise Alarm .....	- .....	1
-32	212-3551	DECAL, Preparing Unit to check Hydraulic Oil Level .....	- .....	1

## DECAL IMAGES

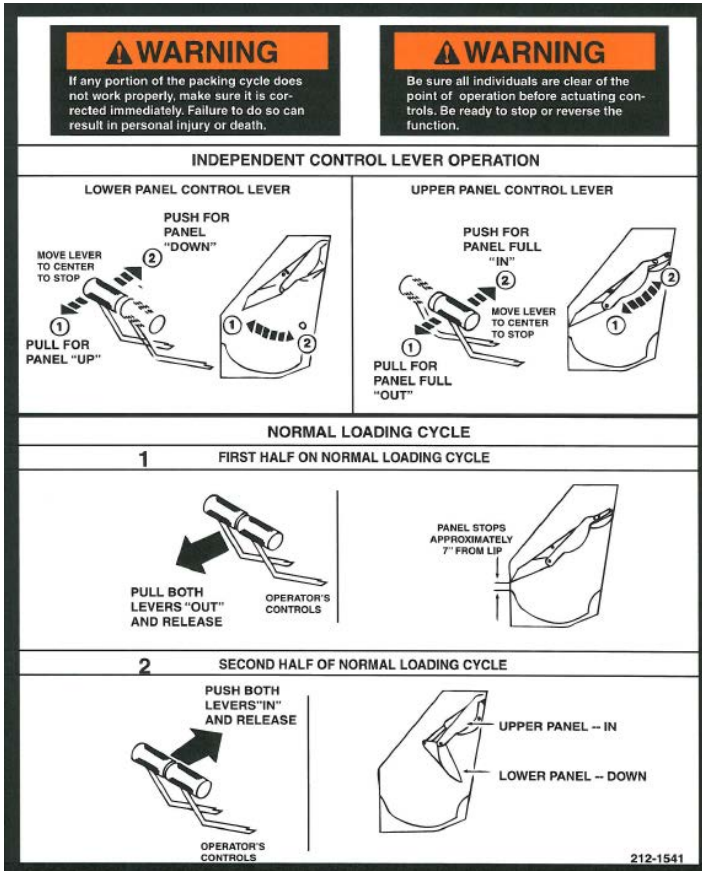

Figure 6. Warning: Control Lever Operation, PN 212-1541



Figure 7. Danger: Stand clear tailgate, PN 212-1801

## DECAL IMAGES (CONTINUED)



Figure 8. Warning: Lock-out / Tag-out, PN 212-1781



Figure 9. Warning: Operations manual, PN 212-1783



Figure 10. Danger: Do not enter under, PN 212-1764



Figure 11. Danger: Stand clear packer, PN 212-1802

## DECAL IMAGES (CONTINUED)

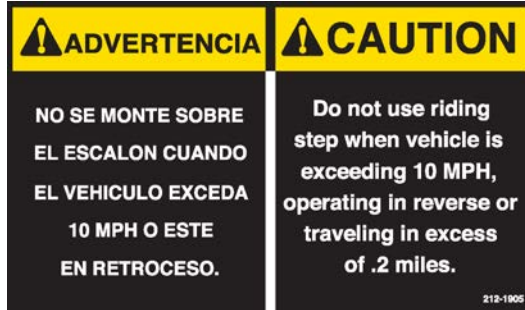

Figure 12. Caution: Riding Step Speed Limit, PN 212-1905



Figure 13. Caution: Stand clear panel, PN 212-1911

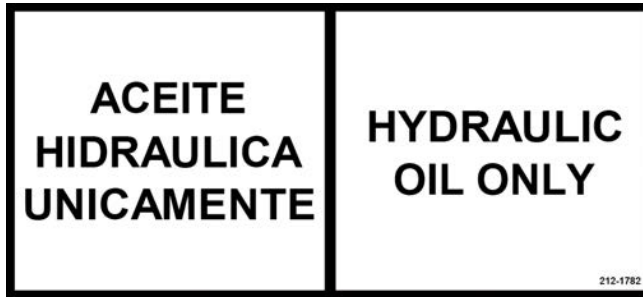

Figure 14. Hydraulic Oil Only, PN 212-1782



Figure 15. Danger: Not for towing, PN 212-1821

## DECAL IMAGES (CONTINUED)



Figure 16. Warning: Do not cross/stand behind, PN 212-2691



Figure 17. Danger: Stay clear container, PN 212-1899

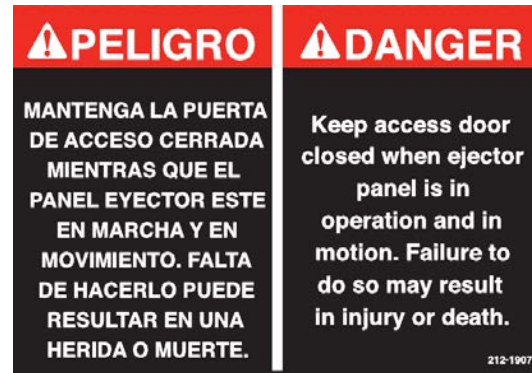

Figure 18. Danger: Keep access door closed, PN 212-1907

## DECAL IMAGES (CONTINUED)

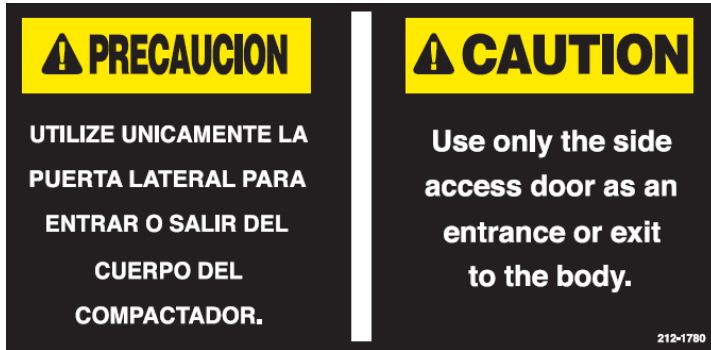

Figure 19. Caution: Side access door only, PN 212-1780



Figure 21. Buzzer, PN 212-1903



Figure 20. Warning: Overall height, PN 212-1909



Figure 22. Caution: Disengage P.T.O., PN 212-1968

## DECAL IMAGES (CONTINUED)



Figure 23. Safety Requirements, ANSI, PN 212-1841



Figure 24. Throttle Advance, ANSI, PN 212-1904

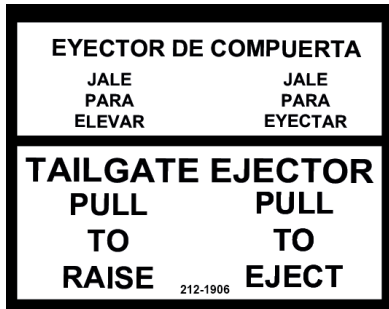

Figure 25. Tailgate/Ejector Operation, PN 212-1906

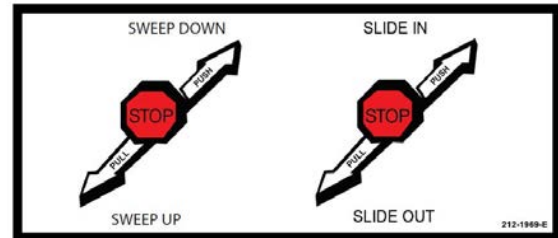

Figure 26. Sweep/Slide Controls, PN 212-1969

## DECAL IMAGES (CONTINUED)



Figure 27. Caution, Riding Step, ANSI, PN 212-1902



Figure 28. Flag, Made in USA, PN 212-2689

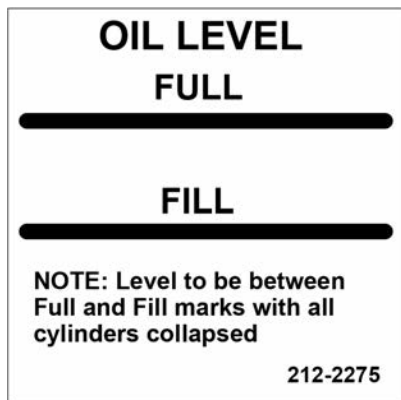

**Figure 29. Oil Level, PN 212-2275**

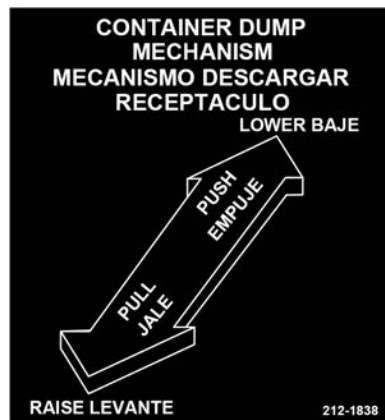

**Figure 30. Container Dump Mechanism Controls, PN 212-1838**

## DECAL IMAGES (CONTINUED)



**Figure 31. Winch Mechanism Controls, PN 212-1839**



**Figure 32. Heil Replacement Parts, PN 212-1915**

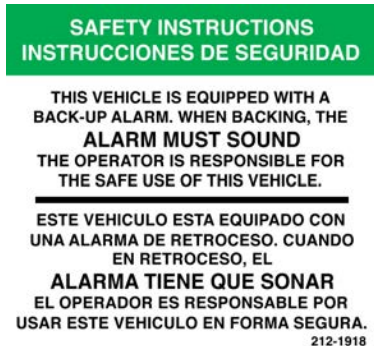
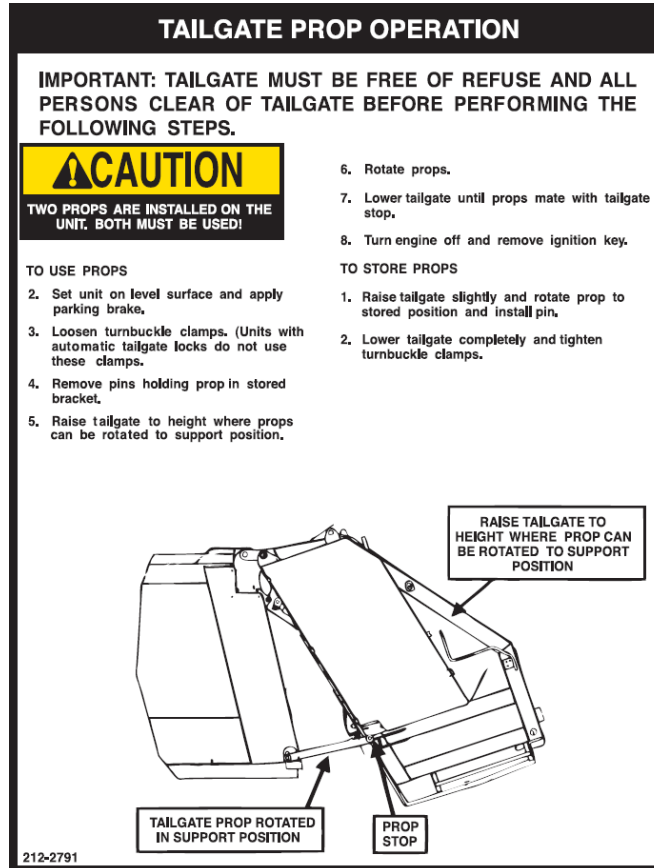

**Figure 33. Safety Instructions, Back-Up Alarm, PN 212-1918**



**Figure 34. Tailgate Raise Alarm, PN 212-1970**

## DECAL IMAGES (CONTINUED)



**Figure 35. Caution: Tailgate Prop Operation, PN 212-2791**

# DURAPACK 5000

## DECAL IMAGES (CONTINUED)

<b>DuraPack® 5000 Lubrication Guide</b>			
<p><b>Note:</b> Clean fittings then pump grease into fittings. Always pump enough grease to flush old grease from fittings. Remove excess grease from fittings.</p> <p><b>Note:</b> Lubricate moveable, mechanical parts with non-detergent motor oil every 60 days.</p>			
REF. NO.	LOCATION	QTY.	INTERVAL
1	Tailgate Hinge	2	Weekly/40 Hours
2	Outside Packing Cylinder (Both Ends)	4	Weekly/40 Hours
3	Tailgate Raise Cylinder (Both Ends)	4	Weekly/40 Hours
4	Lower Link Pivot (Both Ends)	4	Weekly/40 Hours
5	<b>Control Handles/Linkage:</b>		Weekly/40 Hours
	A. Upper Bellcranks	2	
	B. Kick-Out Lever	1	
	C. Lower Yoke Ass'y	2	
	D. Control Handle Pivots	2	
6	Packer Panel Pivot (Bottle Pin to Upper Panel)	4	Weekly/40 Hours
7	Inside Packing Cylinder (Both Ends)	4	Weekly/40 Hours
8	Upper Link Arms	4	Weekly/40 Hours
9	PTO (Pump) Drive Shaft	4	Weekly/40 Hours
	Front Mount Drive Shaft	3	Weekly/40 Hours
10	Tailgate Turnbuckle Clamps	2	Weekly/40 Hours
11	<b>Container Mech. Control:</b>		Weekly/40 Hours
	A. Handle	1	
	B. Upper Pivot	1	Weekly/40 Hours
12	Ejector Cylinder (Not Shown)	2	Weekly/40 Hours

212-1542

Figure 36. Lubrication Guide, PN 212-1542

# DURAPACK 5000

## DECAL IMAGES (CONTINUED)

**HYDRAULIC  
OIL ONLY  
40.6 GAL. FILL  
SYSTEM PRESSURE  
2700 P.S.I.**

Figure 37. Hydraulic Oil Only, PN  
212-2567



Figure 38. City Logo, PN 212-2443

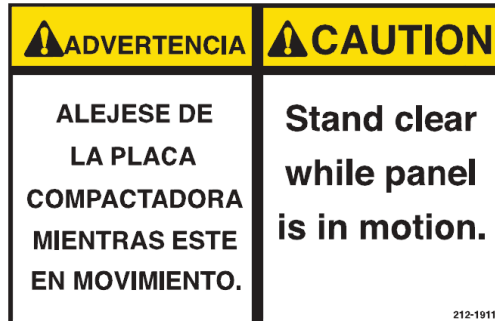

39. Stand Clear, PN 212-1911



40. Sump Door, PN 212-2067

## REFLECTIVE SAFETY MATERIALS

See the Parts and Service Manual for the location and part numbers of the reflective safety materials on the unit.

### NOTICE

---

Replace any safety material with new safety material if the old safety material is lost, destroyed, painted over or cannot be seen. When you replace a part that had safety material on it, make sure you install new safety material on the new replacement part. See the Parts and Service Manual for all part numbers and location of the safety materials.

You can purchase replacement decals from your **Heil Dealer** or from the **Heil Parts Central, 800-528-5308**.

---

## CARE OF DECALS

It is important that the decals are properly cleaned to make sure that they are readable and do not come off the unit. Use the following steps to clean the decals.

### General Instructions

- Wash the decals with a blend of mild car wash detergent and clean water.
- Rinse with clean water.
- Let the vehicle air-dry or dry with a micro-fiber cloth.
- Do not allow fuels to stay in contact with the decal for an extended period of time. Remove the fuel contamination as quickly as possible.
- Do not use carnauba-based wax over the decals.
- Do not use a mechanical brush while washing the decals.

### Pressure Washer Precautions

- Pressure washing can cause damage to decals. It can cause the edges of the decals to lift and peel the decal away from the unit. Over time, the decal can fade, crack or chip away.
- See the following figures for correct and incorrect methods of pressure washing.
- Use pressure washing only when other cleaning methods are not effective. If you use a pressure washer, use the following precautions.
  - Spray nozzle opening: 40° wide pattern
  - Spray angle: 65° from vehicle's body
  - Distance of nozzle to decal: 15" minimum
  - Water pressure:  $\leq 800$  psi
  - Length of time: not more than 30 sec.
  - Do not use sharp angles to clean the decals – this can lift the decals from the unit.
  - NEVER use a “turbo pressure nozzle”.

## PRESSURE WASHER TECHNIQUE

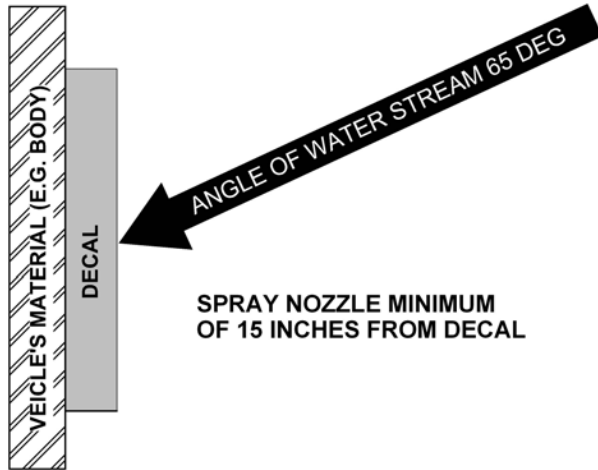

RECOMMENDED TECHNIQUE

Figure 41. Recommended Technique

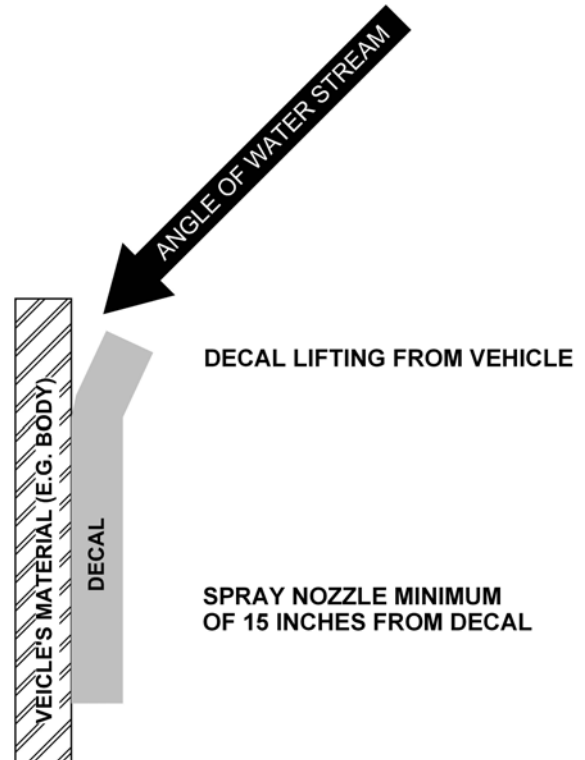

INCORRECT TECHNIQUE

Figure 42. Incorrect Technique

## ALTERNATIVE CLEANING PROCEDURE

When normal cleaning procedures do not remove difficult debris from the decals, try the following:

---

** WARNING**

---

Isopropyl alcohol is flammable and is harmful to eyes and skin. Keep isopropyl alcohol away from heat or open sources of ignition. Flush eyes and skin with water for 15 minutes after contact. Seek immediate medical help.

---

- Spot clean the decal with Isopropyl Alcohol and a micro-fiber cloth (rag).
- If these methods do not work on a problem area, call a Heil Dealer or Heil Customer Service.

**SECTION 3**  
**LOCK-OUT/TAG-OUT PROCEDURE**

## PREVIEW

Read this section to learn about the proper Lockout/Tagout procedures.

You MUST Lockout/Tagout a unit BEFORE:

- You enter the body
- Do any maintenance or repair procedures.

## LOCKOUT/TAGOUT PROCEDURE

### **DANGER**

This procedure **MUST** be followed before entering the units body or performing any maintenance repair or cleaning procedures on the unit.

### **WARNING**

If you do not have functioning Lockout/Tagout gear and/or are not an authorized employee, **STOP** and **DO NOT** initiate any service on the unit. Contact your supervisor immediately.

### **NOTICE**

This Lockout/Tagout procedure represents Heil's minimum recommendation and should be used in conjunction with and should not supersede additional or more stringent safety requirements called out by your company's policy. Please check with your supervisor to determine if your company has a specific Lockout/Tagout procedure. Contact your supervisor, Heil Technical Service, or reference OSHA Regulation 1910.147 if you have any questions about Lockout/Tagout.

Watch the Service Shack Video online at [www.Heil.com/Heil-Service-Shack](http://www.Heil.com/Heil-Service-Shack) by selecting **Lock-Out/Tag-Out**.

#### A. Put the unit in a Lockout/Tagout mode:

- BEFORE you enter the unit's body
- BEFORE you perform ANY maintenance, repair or cleaning procedures on the unit.

#### B. All stored energy must be removed and/or protected against, common sources found on Heil units (Including, but not limited to):

- Hydraulics
- Electrical
- Gravity
- Pneumatics
- Mechanical

#### C. Examples of some basic equipment required, see Figure:

- Multi-hasp
- Single-keyed red lock
- Lockout tag

## LOCKING OUT THE UNIT (CONTINUED)

C. Examples of some basic equipment required, see Figure:

- Multi-hasp
- Single-keyed red lock
- Lockout tag



**Figure 43.**  
**Lock-Out/Tag-Out Tag**  
**(Do Not Operate Tag)**

Follow These Steps:

1. APPLY the brakes. MAKE SURE the brakes do not let the unit move and they work properly.
2. Chock all wheels.
3. SET the tailgate props when the tailgate is raised for any service, maintenance or cleaning.
4. SET the body props when the body is raised for any service, maintenance or cleaning.

1. BEFORE disconnecting main battery power, VERIFY all the following stored energy sources are depleted according to your company policy:
  - a. Hydraulic (Such as forks or grabber arm in stowed position)
  - b. Pneumatic (Such as tag axles).
  - c. Mechanical (Such as springs)
  - d. Gravity (Such as tailgate raised)
6. REMOVE the key from the ignition and store it in your pocket, or another secured location for your safety.
7. Disconnect the battery power by flipping the battery box disconnect switch to OFF.
  - a. VERIFY all electrical stored energy is depleted according to your company procedure.
8. INSERT the multi-hasp into the disconnect switch.
9. ATTACH your red single-keyed Lockout/Tagout lock with your tag exposed and visible to the multi-hasp.
  - a. ALWAYS use individually assigned locks and tags when performing ANY service or maintenance with other authorized employees. Each employee MUST place their personally assigned tag and lock to the multi-hasp connected to the disconnect switch.

## LOCKING OUT THE UNIT (CONTINUED)

10. REMOVE your lock key and put it in your pocket for your safety.
  - a. ONLY the person who placed the lock and tag on the multi-hasps is authorized to remove it.
  - b. NEVER remove another employee's Lockout/Tagout gear without approval from the authorized person responsible.
  - c. Shift or personnel changes: Off-going employees MUST provide all details pertaining to the unit's status to the oncoming employee(s). The oncoming employee(s) MUST perform the Lockout/Tagout procedure to verify all stored energy is removed from the unit BEFORE applying their Lockout/Tagout gear.
11. BEFORE removing your Lockout/Tagout gear to return the unit to service, follow these steps:
  - a. INSPECT the work area to ensure all nonessential items have been removed.
  - b. VERIFY all unit components are operationally intact.
  - c. ENSURE all employees are safely positioned or removed from the area.
  - d. NOTIFY all affected employees that the Lockout/Tagout devices are being removed.

# DURAPACK 5000

**NOTES:**

# **SECTION 4**

# **IN-CAB DISPLAY AND CONTROLS**

## PREVIEW

Read this section to learn about the operation of the in-cab display controls and indicator messages, outside controls, switches and buttons.

### NOTICE

---

The location and appearance of the controls may be different than those shown in this manual. Make sure you know the location of the controls and how you operate the controls on your unit before you use the vehicle.

---

This section explains:

- The unit's features and operation specifications
- The in-cab display, controls, switches and buttons
- The in-cab display messages
- The outside controls and how they work

# DURAPACK 5000

## CONTROLS

The unit's standard controls are located on the In-Cab InSight Diagnostic Display and on the body. The standard controls in the cab enable the hydraulic pump and the throttle advance. The hydraulic controls are installed on the street side of the body (tailgate and ejector panel controls) and on the curb side of the body (upper panel and sweep).

The controls for optional equipment are located on the curb side of the body. These controls include cart tippers, reeving mechanism and winch.

## IN-CAB DISPLAY

The InSight Diagnostic Display shows the Operator important system information including display indicators, status, critical fault messaging and counter information and allows a qualified and authorized Service Technician to see detailed system information and make configuration changes based on option configuration.

### Display Screens

1. Home Screen
2. Display Screen
3. Cab Controller Inputs Screen
4. Body Controller Inputs Screen
5. Tailgate Controller Inputs Screen
6. Chassis Variables (J1939) Screen
7. Cab Controller Outputs Screen
8. Body Controller Outputs Screen
9. Tailgate Controller Outputs Screen
10. Critical Faults Screen
11. System Faults Screen
12. Controller Faults Screen
13. Password Protected Screens
14. Option Config Screen
15. Maintenance Screen

# DURAPACK 5000

## HOME SCREEN

Use the image below to identify the locations of the display indicators, function buttons, directional arrow buttons, "esc" and "ok" buttons, message banner, and status LED.

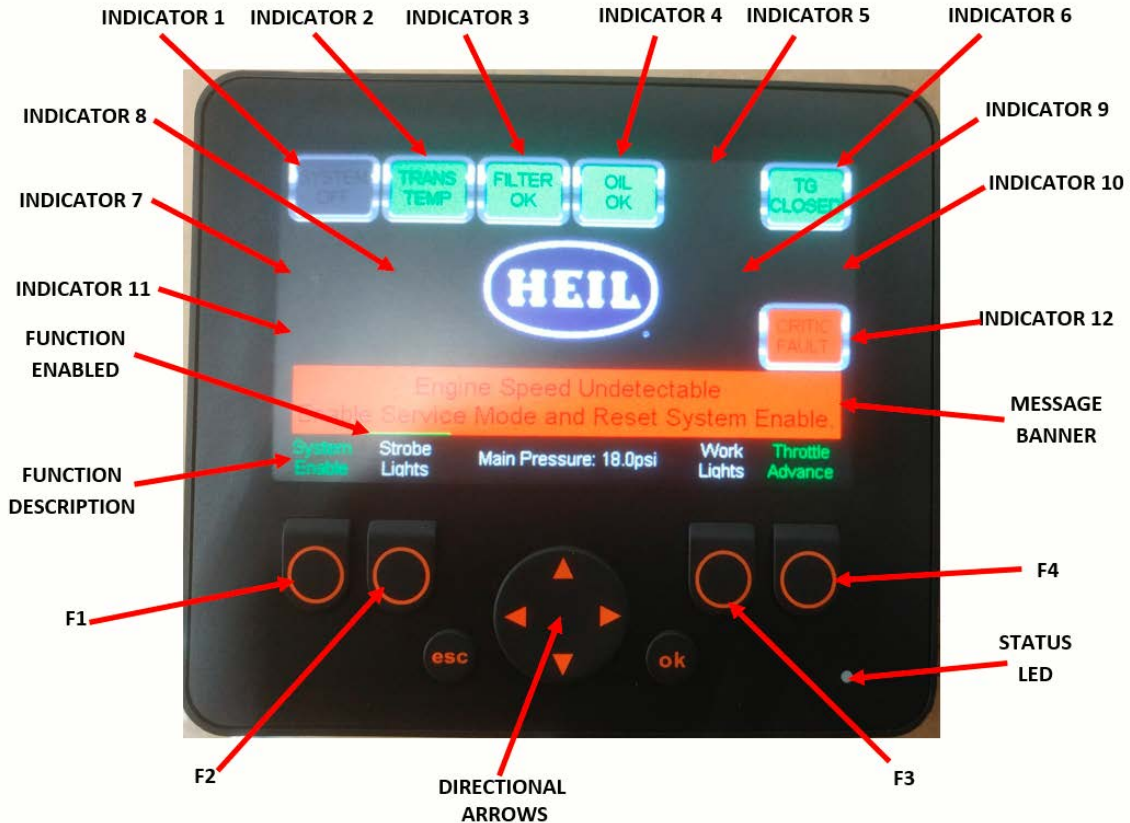

## HOME SCREEN (CONTINUED)

### Function Buttons

Each button is assigned multiple functions which change by scrolling the DOWN directional arrow. Button Functions are listed below. The state of functions assigned to F2, F3 and F4 are retained through a power cycle. Function text will be green when function is enabled, white when not.

Other than System Enable, all other functions that you enable will be saved as a custom setup that will reload even after you cycle the power of the unit.

#### 1. F1 Function Button

- **System Enable** – enables the hydraulic system

#### 2. F2 Function Button

- **Strobe Lights** – turns on all strobes.
- **Auto Strobe** – turns on all strobes with System Enable and Vehicle Speed below 20 MPH.
- **Rear Strobe** – turns on all strobes on the rear of the vehicle.
- **Front Strobe** – turns on all strobes on the front of the vehicle.

#### 3. F3 Function Button

- **Work Lights** – turns on body Work Light #1 and all tailgate Work Lights.
- **Auto Work Lt** – turns on body Work Light #1, tailgate hopper and tailgate side lights with System Enable and Vehicle Speed below 20MPH.

#### 3. F3 Function Button (Continued)

- **Inside Hopper** – turns on tailgate hopper light.
- **Outside Hopper** – turns on tailgate side light.
- **Back-Up Assist** – turns on side body Backup Assist lights.
- **Camera Floods** – turns on tailgate camera lights.

#### 4. F4 Function Button

- **Throttle Advance** – Enables engine throttle advance.
- **Option Switch 1** – turns on Option Output #1 in the Body Controller, must be enabled in Option Screen
- **Option Switch 2** – turns on Option Output #2 in the Body Controller, must be enabled in Option Screen

#### 5. Functions Enabled

- This GREEN line above a Function Description indicates the function assigned to that button is enabled. It is necessary to scroll down through the functions in order to identify the enabled function(s).

## HOME SCREEN (CONTINUED)

### Display Indicators

#### 1. **System/PTO** - Indicates PTO or System Status

On units with a Clutch Shift PTO:

- RED, "ERROR" – PTO output error.
- GREEN, "PTO ON" – PTO output ON and PTO pressure switch is activated
- YELLOW, "PTO ON" – PTO output ON but PTO pressure switch is not activated
- GRAY, "PTO OFF" – PTO output OFF.

On units without a Clutch Shift PTO:

- GREEN, "SYSTEM ON" – Hydraulic System is enabled.
- GRAY, "SYSTEM OFF" – Hydraulic System is disabled.

#### 2. **Trans Temp** - (Optional) Indicates the High Temp Warning is active on the Allison Transmission. Only applies with Clutch shift PTO.

#### 3. **Filter Bypass**

- GREEN, "FILTER OK" — Return Filter is NOT in bypass.
- RED, "FILTER BYPASS" – Return Filter is in bypass.

#### 4. **Low Oil** - (Optional) Included with Hydraulic Tank Monitoring.

- GREEN, "OIL OK" – Oil Level is Good
- RED, "LOW OIL" – Low Hydraulic Oil

#### 5. **Tailgate Lock** - (Optional) Currently Not Used

- GREEN, "TG LOCKED"
- RED, "TG UNLOCKED"

#### 6. **Tailgate Open**

- GREEN, "TG CLOSED"
- RED, "TG OPEN"

#### 7. **Pump #1** - (Optional) Included with manifold controlled hydraulic pump.

- GREEN, "PUMP ON" – Pump output ON
- GRAY, "PUMP OFF" – Pump output OFF
- YELLOW, "ERROR" – Pump output error, short or open circuit

#### 8. **Unused** - Unused Indicators will be blank.

## HOME SCREEN (CONTINUED)

### Display Indicators (Continued)

9. **Side Door** - (Optional) Included with Side Door Pump Shutdown interlock, indicates Side Door Closed or Open.
  - GREEN, "SIDE DOOR CLOSED"
  - RED, "SIDE DOOR OPEN"
10. **Unused** - Unused Indicators will be blank.
11. **Pump #2** - (Optional) Included with OAI hydraulic pump.
  - GREEN, "PUMP ON" – Pump output ON
  - GRAY, "PUMP OFF" – Pump output OFF
  - YELLOW, "ERROR" – Pump output error, short or open circuit
12. **Fault Indicator**
  - RED, "CRITIC FAULT" – Critical Fault
  - RED, "CTRL. FAULT" – Controller Fault
  - RED, "SYS. FAULT" – System Fault

### Status LED

The Status LED on the bottom-right corner of the display indicates status of the display as described below.

- GREEN, 2Hz Flash – Application Running
- GREEN, 5Hz Flash – No Run time system loaded
- GREEN, Continuous – Application Stopped or No Application Loaded
- RED, 5Hz Flash – Application Stopped due to Low Voltage
- RED, 10Hz Flash – Application Stopped with error application is stopped
- RED, Continuous – Application Stopped with Fatal Error

## HOME SCREEN (CONTINUED)

### Message Banner

The Message Banner displays important information about the system status. Below are the potential messages that can be displayed.

#### A. Critical Faults – result in disabled functions, allowing limited to no operation. (RED BANNER)

Refer to the Heil DuraPack 5000 Service Manual for a full list of possible faults along with each cause, effect, and method of reset.

1. “Engine Speed Undetectable, Enable Service Mode and Reset System Enable.” J1939 Communication with the Engine have been lost or, the Alternator R stator connection lost. To override and continue operation, enter Service Mode.
2. “Side Door Interlock. Close Side Door Reset System Enable.” To override and continue operation, enter Service Mode.
3. “Hydraulic Temp Shutdown. Oil Temp Exceeds 200° F Reset System Enable.” Allow system to cool and reset by cycling system enable switch. To override and continue operation, enter Service Mode.
4. “Transmission Temp High w/Clutch Shift PTO engaged, Reset System Enable. “ Allow system to cool and reset by cycling system enable switch. To override and continue operation, enter Service Mode.

#### A. Critical Faults (Continued)

5. “Pump Shutdown Pressed, Reset Street side Switch, Restart System Enable.” Optional Pump Shutdown System. To override and continue operation, enter Service Mode.
6. “Pump Shutdown Pressed, Reset Curbside Switch Restart System Enable.” Optional Pump Shutdown System. To override and continue operation, enter Service Mode.
7. “Low Hydraulic Oil. Fill hydraulic tank to proper level, Reset System Enable” To override and continue operation, enter Service Mode.

#### B. Operator Warnings – hazardous operating conditions. (RED BANNER)

1. “Vehicle in motion with TG open. Close and secure TG”
2. “Hydraulic Temp Warning Oil Temp Exceeds 180° F.”
3. “Vehicle in motion with Throttle Advanced. Verify Transmission Neutral.” MPH exceeded zero with throttle advance engaged. Throttle Advance is temporarily disabled. Indication of potential issue with the chassis Neutral signal.

## HOME SCREEN (CONTINUED)

### Message Banner (Continued)

C. Communication Failure – either intermittent or ongoing, between one or more controllers. Press ESC button to acknowledge. (RED BANNER)

1. “Comms Lost, Multiple Controllers, Restore Comms and, press escape to clear.”
2. “Cab Controller Communication Lost, Restore Comms and, press escape to clear.”
3. “Body Controller Communication Lost, Restore Comms and, press escape to clear”
4. “Tailgate Controller Communication Lost, Restore Comms and, press escape to clear.”

### D. Miscellaneous

1. Service Mode – system has been placed in service mode (RED BANNER)  
“SERVICE MODE!!!”
2. Tailgate Buzzer – visual indication that the Tailgate Buzzer switch is pressed (BLUE BANNER)  
“OPERATOR ALERT”
3. Hydraulic Filter Life – remaining filter life is below 5%. (BLACK BANNER)  
“Hyd. Oil Filter Life @: ##%”  
Hydraulic filter should be changed every 1000 pump hours.

### D. Miscellaneous (Continued)

4. Hydraulic Oil Life – remaining oil life is below 5% (BLACK BANNER)  
“Hyd. Oil Life @: ##%”  
Hydraulic oil should be changed every 2000 pump hours.
5. Hydraulic Oil/Ambient Temp – (Optional) displayed as default message (BLACK BANNER)  
“Hyd. Oil Temp.: ##° F”  
“Ambient Temp.: ##° F”
6. System OFF – Hydraulic System is turned off (GRAY BANNER)  
“System OFF”

## COUNTER SCREEN



### A. Cycle Counts

1. Total Cycles are non-resettable counts, retained throughout the life of the unit controller.
2. Daily Cycles can be reset. Choose the count to be reset by scrolling down using the directional arrow.
3. TG Packer count is achieved by monitoring the tailgate Slide Active proximity switch. To account for the split pack cycle, the Slide Active must engage two separate instances for a minimum of 7 seconds. Tipper counts are achieved by monitoring the Tipper #1 and Tipper #2 inputs. To achieve a count the input must remain on for 2 seconds.

### B. Hour Counts

1. Maintenance Hours count the hours the hydraulic pump/PTO is enabled.
2. Hyd. Filter Life displays remaining life if the hydraulic filter based upon 1000 hours of pump operation.
3. Hyd. Oil Life displays remaining life if the hydraulic oil based upon 2000 hours of pump operation.

### C. Other

1. Oil Temp High records the highest hydraulic oil temperature since reset.

## DIAGNOSTIC, MAINTENANCE, AND OPTION CONFIGURATION SCREENS

Additional screens allow a qualified and authorized Service Technician to see detailed system information and make configuration changes based on option configuration.

Refer to the Heil DuraPack 5000 Service Manual for more information on these screens.

1. Display Screen
2. Cab Controller Inputs Screen
3. Body Controller Inputs Screen
4. Tailgate Controller Inputs Screen
5. Chassis Variables (J1939) Screen
6. Cab Controller Outputs Screen
7. Body Controller Outputs Screen
8. Tailgate Controller Outputs Screen
9. Critical Faults Screen
10. System Faults Screen
11. Controller Faults Screen
12. Password Protected Screens
13. Option Config Screen
14. Maintenance Screen

## NOTES:

## STANDARD OUTSIDE CONTROLS

The standard outside controls for the unit are located on the front street side of the body and on the curb side of the tailgate near the hopper.

The upper panel and packer blade levers have detents. Once you push or pull the lever past the detent (fully push or pull the lever), the selected operation continues and you can release the lever. The lever will self-center at the end of the commanded operation by way of internal hydraulic pressure. You can reverse the direction of a function at any time when you push or pull the lever past the detent in the opposite direction.

You must move the tailgate and ejector levers in the direction of travel you want and hold the lever at that position until the tailgate or ejector reaches the desired position then release the lever. You can stop an operation at any time by releasing the lever.

### **DANGER**

Your body or clothing can become caught by the blade while it moves. Serious injury or death may occur if a person is in or near the hopper when the blade and upper panel move. Clear the area near the hopper of all unnecessary people before you move the blade and upper panel and keep all parts of your body away from the blade.

#### A. PACKER BLADE Lever

This lever is on the curb side of the tailgate next to the UPPER PANEL lever. It is the lever closest to the end of the tailgate. See the figures on the next two pages.

1. PUSH the lever to the FULL DOWN position and RELEASE it to MOVE the blade UP.
2. PULL the lever to the FULL UP position and RELEASE it to MOVE the blade DOWN.
3. MOVE the lever in the opposite direction to stop an UP or DOWN operation at any time.
4. You usually operate this lever at the same time you operate the UPPER PANEL lever to:
  - a. OPEN the hopper to load refuse
  - b. CLOSE the hopper for the in-transit position
  - c. MOVE and COMPACT the refuse in the hopper to the body.

#### B. UPPER PANEL Lever

This lever is on the curb side of the tailgate next to the BLADE lever. See the figures on the next two pages.

1. PULL the lever to the UP position and RELEASE it to MOVE the upper panel IN.
2. PUSH the lever to the DOWN position and RELEASE it to MOVE the upper panel OUT.
3. MOVE the lever in the opposite direction to stop an IN or OUT operation at any time.
4. You usually operate this lever at the same time you operate the BLADE lever to:
  - a. OPEN the hopper to load refuse
  - b. CLOSE the hopper for the in-transit position
  - c. MOVE and COMPACT the refuse in the hopper to the body.

## STANDARD OUTSIDE CONTROLS (CONTINUED)

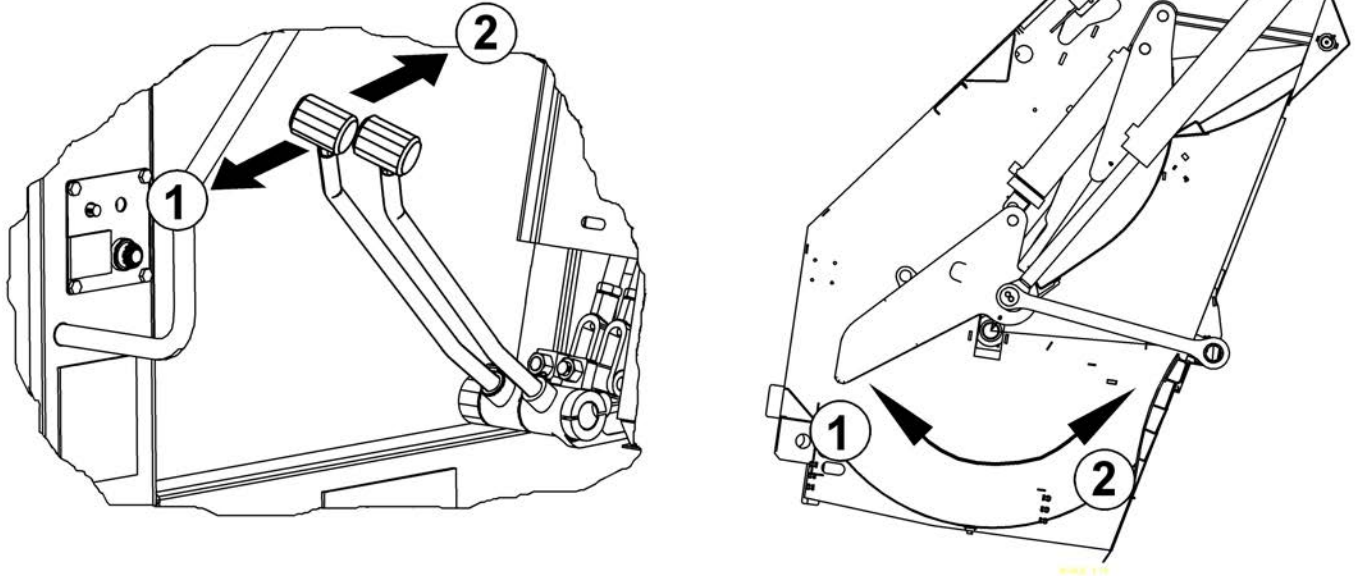

Figure 44. Sweep Control Lever

## STANDARD OUTSIDE CONTROLS (CONTINUED)

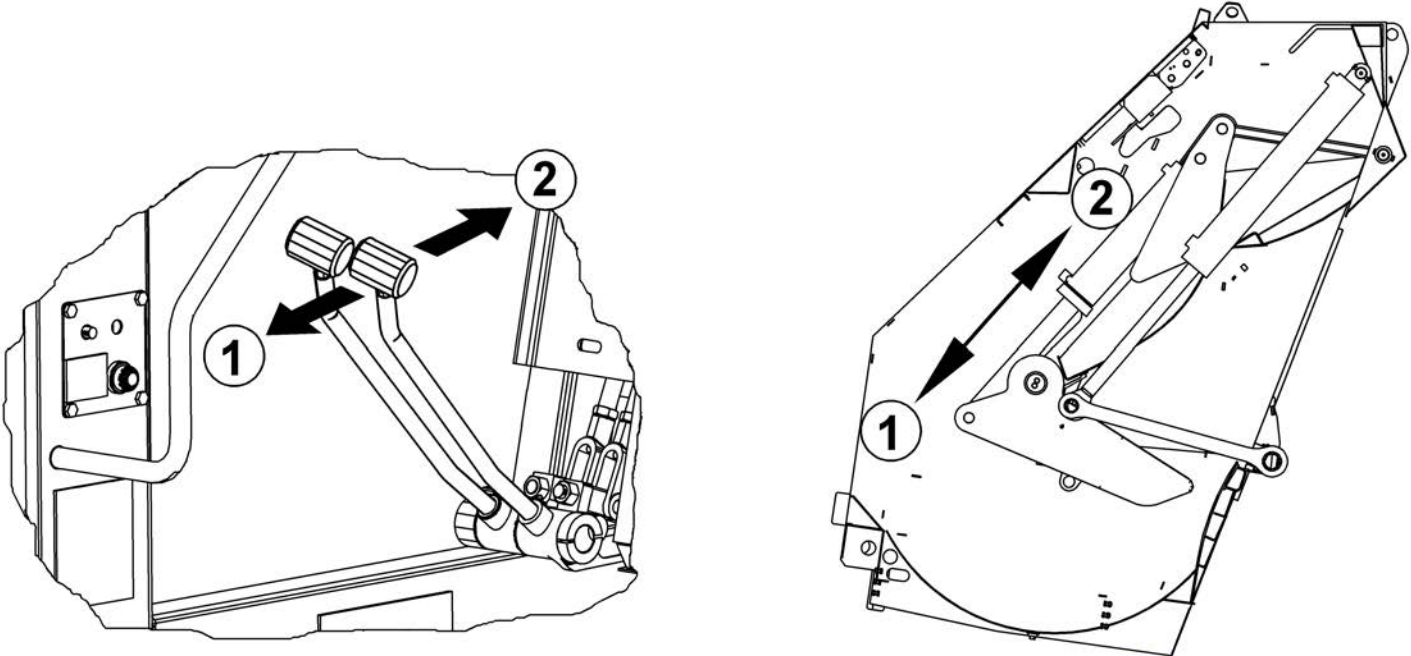
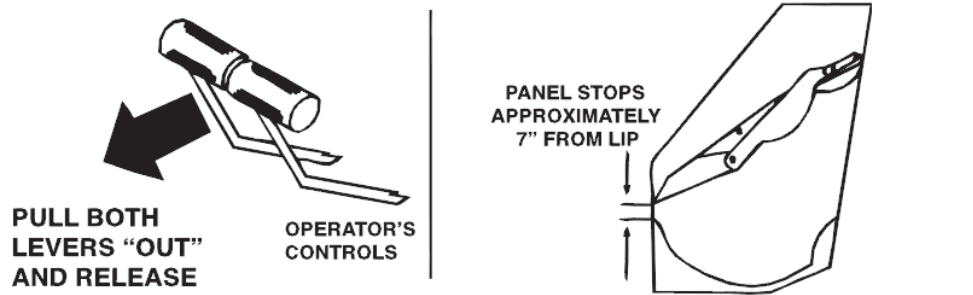

Figure 45. Sweep Panel Control Lever

## STANDARD OUTSIDE CONTROLS (CONTINUED)

### NORMAL LOADING CYCLE

#### 1 FIRST HALF ON NORMAL LOADING CYCLE



#### 2 SECOND HALF OF NORMAL LOADING CYCLE

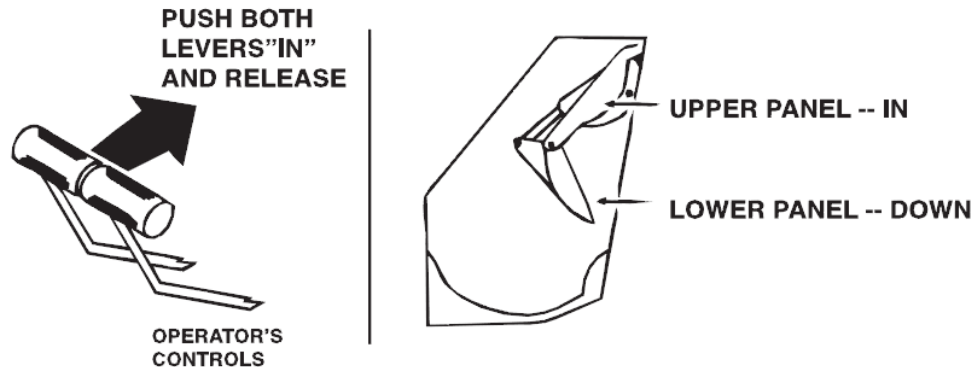

Figure 46. Normal Loading Cycle

## STANDARD OUTSIDE CONTROLS (CONTINUED)

### **DANGER**

A tailgate in motion is dangerous. Serious injury or death may occur if a person is struck by a moving tailgate or becomes trapped between the tailgate and the body. Clear the area near the tailgate of all unnecessary people before you lower the tailgate.

### C. TAILGATE Lever

This lever is on the front, street side of the body and controls the raising and lowering of the tailgate. See the figure on the next page.

1. PULL the lever to the UP position and HOLD it there to raise the tailgate.
2. PUSH the lever to the DOWN position and HOLD it there to lower the tailgate.
3. RELEASE the lever to stop an UP or DOWN operation at any time or when the tailgate is fully raised or lowered.
4. The TAILGATE OPEN indicator light on the in-cab display is RED (TG OPEN) when the tailgate is NOT FULLY CLOSED and turns GREEN (TG CLOSED) when it is fully CLOSED.
- 4.

### **DANGER**

Stand clear when the ejector panel is in motion. Keep side access door closed when ejector panel is in motion. Failure to obey may result in severe injury or death.

### **NOTICE**

Do not use the ejector panel to pack refuse against a closed tailgate (backpack). Packing refuse against a closed tailgate may result in damage to body or ejector cylinder.

### D. EJECTOR Lever

This lever is on the front, street side of the body and is next to the TAILGATE lever. This lever controls the EXTEND and RETRACT functions of the ejector panel. You EXTEND the ejector panel when you want to push refuse out of the body and you RETRACT the ejector panel after body is empty of refuse. You also set the position of the ejector panel at the start of a route before you load any refuse. See the figure on the next page.

1. PULL the lever to the UP position and HOLD it there to EXTEND the ejector panel and push refuse out of the body.
2. PUSH the lever to the DOWN position and HOLD it there to RETRACT the ejector panel after it pushes the refuse from the body.
3. RELEASE the lever to stop an EXTEND or a RETRACT operation at any time or when the ejector panel is fully EXTENDED or RETRACTED.

## STANDARD OUTSIDE CONTROLS (CONTINUED)

### E. THROTTLE ADVANCE Switch

Use this switch to increase engine RPMs and the flow of hydraulic fluid when you use the ejector panel to push refuse out of the body. You must enable this switch by MOVING the in-cab THROTTLE ADVANCE enable switch to ON. See the figure below.

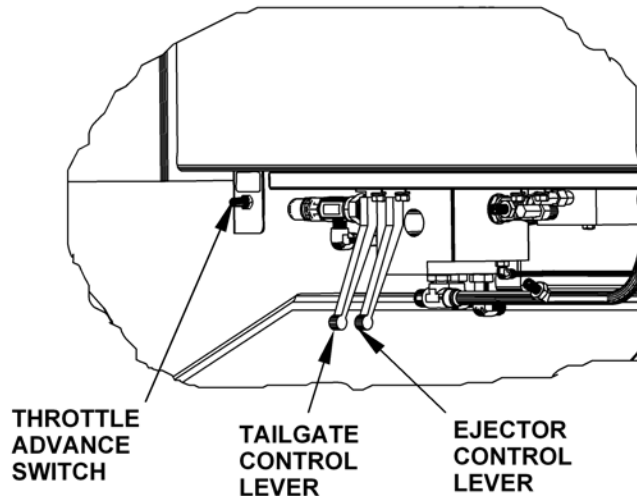

Figure 47. Front Street Side Controls

### F. BUZZER Switch

Without any options, this switch is located on curb side of the tailgate near the grab handle. This switch may be located in different areas depending on optional container lifting devices. See the figure below.

1. PUSH the switch IN to activate the buzzer in the cab when the helper is on the riding step and ready for the unit to move to the next pickup location.
2. RELEASE the switch to stop the buzzer in the cab.
3. MAKE SURE you (the helper) are ready for the unit to move. This means that you observe the safety message for using the riding step.

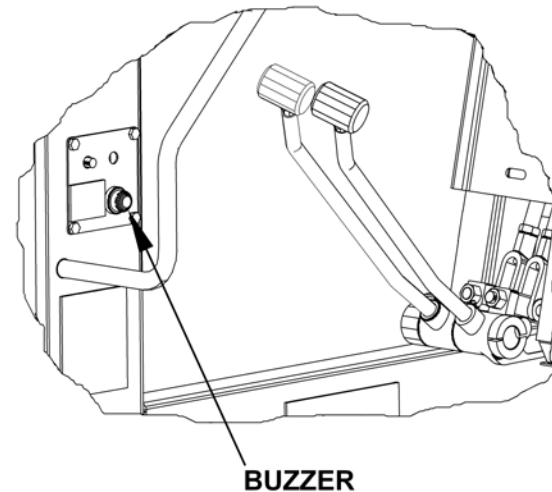

Figure 48. Buzzer Switch Location

## STANDARD OUTSIDE CONTROLS (CONTINUED)

### G.HOPPER LIGHT Switch (Option)

If equipped, use this switch to turn on the Hopper Light.  
See the figure to the right.



**Figure 49. Buzzer and Hopper Light Switch Location**

## OPTIONAL OUTSIDE CONTROLS

The optional outside controls include levers to operate the optional hydraulic equipments such as:

- Reeving mechanism
- Winch
- Arm mechanism
- Roll bar
- Cart tipper

There are several combinations of optional equipment. The controls for optional equipment are usually located on the curb side of the unit, but may also be located on the street side of the unit. You must become familiar with the optional equipment and their controls that are on your unit. See the figure to the right.

You must secure the refuse bin with the latch bar before you lift the refuse bin with any of the optional container lift equipment except the arm mechanism and the cart tipper.

An additional throttle advance toggle switch is installed when there is at least one optional lifting equipment. The switch is a momentary switch which means that you must PRESS and HOLD the switch to increase the engine RPMs. It is located on the same plate as the buzzer. The engine RPMs decrease as soon as you stop pressing the switch. You use the switch to increase the RPMs of the engine which increases the hydraulic oil flow. The increased flow of hydraulic oil increases the speed of the optional lifting equipment.

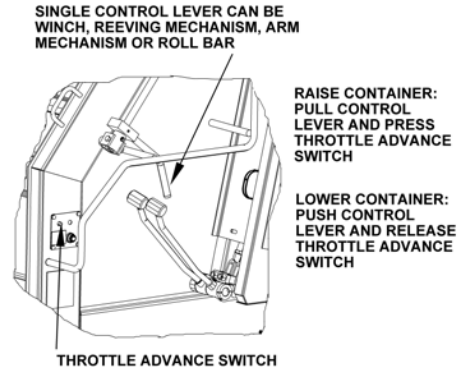

CONTROL LEVER FOR SINGLE OPTION  
**Figure 50. Optional Container Lift Controls (1 of 2)**

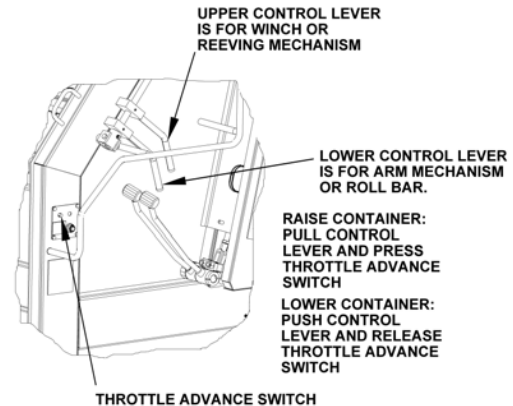

CONTROL LEVERS FOR TWO OPTIONS  
**Figure 51. Optional Container Lift Controls (2 of 2)**

## OPTIONAL OUTSIDE CONTROLS (CONTINUED)

### **DANGER**

Container lifting equipment in motion is dangerous. Serious injury or death may occur if a person is struck by a refuse container or the lifting equipment. Clear the area near the tailgate of all unnecessary people before you use the container lifting equipment.

### **WARNING**

A refuse container that is not in good condition with retaining washers in place may not be secured with the latch bar and can suddenly move. Death or serious injury can occur when a person is struck by a moving container that is not properly secured. Make sure the refuse container is properly secured to the latch bar before you raise or lower the container.

## A. REEVING MECHANISM

An optional reeving mechanism (a cylinder with an attached cable and hook) will be located along the center line of the roof with its hook end at the top of the tailgate. When not in use, you secure its hook in the eye provided on either side of the tailgate. You use the reeving mechanism and its hook to secure a commercial refuse bin, pull it to the hopper, tip the bin to empty the refuse into the hopper and lower the bin to the ground.

1. PUSH the lever to the LOWER position and HOLD it there to MOVE the cylinder OUT (EXTEND).
2. PULL the lever to the RAISE position and HOLD it there to MOVE the cylinder IN (RETRACT).
3. RELEASE the lever to stop a RAISE or LOWER operation at any time or when the cable hook is at the position you want.
4. Attach the latch bar to the refuse bin **BEFORE** you attach the hook to the refuse container.
5. PULL/PUSH the lever to RAISE the container over the hopper lip, dump the refuse from the container and lower the container to the ground.

## B. WINCH

An optional winch will be mounted at the top, center of the tailgate. You use the winch and its hook to secure a commercial refuse bin, pull it to the hopper, tip the bin to empty the refuse into the hopper and lower the bin to the ground. The lever controls the RAISE and LOWER operations of the winch.

1. PUSH the lever to the LOWER position and HOLD it there to UNWIND the cable.
2. PULL the lever to the RAISE position and HOLD it there to the WIND the cable.
3. RELEASE the lever to stop at LOWER or RAISE operation at any time or when the cable hook is at the position you want.

## OPTIONAL OUTSIDE CONTROLS (CONTINUED)

4. Attach the latch bar to the refuse bin **BEFORE** you attach the hook to the refuse container.
5. PULL/PUSH the lever to RAISE the container over the hopper lip, dump the refuse from the container and lower the container to the ground.

### C. ARM MECHANISM

The optional arm mechanism consists of a lift arm on each side of the tailgate connected by a cross tube. Each lift arm hooks onto a trunnion bar on the refuse container. Each arm is raised and lowered by a cylinder. The two cylinders are controlled by a single lever.

1. PUSH the lever to the LOWER position and HOLD it there to LOWER the roll bar.
2. PULL the lever to the RAISE position and HOLD it there to RAISE the roll bar.
3. RELEASE the lever to stop an LOWER or RAISE operation at any time or when the roll bar is at the position you want.
4. MAKE SURE the refuse container is SECURED by the arm mechanism **BEFORE** you RAISE or LOWER the refuse container.
5. PULL/PUSH the lever to RAISE the container over the hopper lip, dump the refuse from the container and lower the container to the ground.

### D. ROLL BAR

The optional roll bar mechanism consists of a lift arm on each side of the tailgate connected by a tube. You raise and lower each arm with two cylinders. A single lever controls the two cylinders.

1. PUSH the lever to the LOWER position and HOLD it there to LOWER the roll bar.
2. PULL the lever to the RAISE position and HOLD it there to RAISE the roll bar.
3. RELEASE the lever to stop an LOWER or RAISE operation at any time or when the roll bar is at the position you want.
4. Attach the latch bar to the refuse bin **BEFORE** you RAISE the refuse container.
5. MAKE SURE the refuse container is SECURED by the latch bar **BEFORE** you LOWER the refuse container.
6. PULL/PUSH the lever to RAISE the container over the hopper lip, dump the refuse from the container and lower the container to the ground.

## OPTIONAL OUTSIDE CONTROLS (CONTINUED)

### E. CART TIPPER

One or two optional cart tipper can be installed on the unit. The control lever for a single cart tipper will be located on the curb side of the tailgate as shown in the figure to the right.

1. Bring the refuse container to the cart tipper and secure the container to the cart tipper with the cart tipper lock.
2. PULL and HOLD the lever to RAISE the cart tipper. The cart tipper will RAISE and (by continuing to PULL the lever) tip the container, thereby dumping the refuse in the hopper.
3. MAKE SURE the container latch bar is over the cart tipper saddle **BEFORE** you RAISE the container.
4. MAKE SURE the cart tipper slider latch EXTENDS and LOCKS the container when you RAISE the container.
5. If the latch does not extend, LOWER the container, make sure the container latch bar is over the cart tipper saddle and RAISE the container again. DO NOT continue to RAISE a refuse container when the slider latch does not extend and lock the container.
6. When the refuse container is empty, PUSH and RELEASE the lever to LOWER the cart tipper. At the end of the LOWER cycle, the cart tipper will stop lowering.

7. RELEASE the refuse container from the cart tipper's lock.

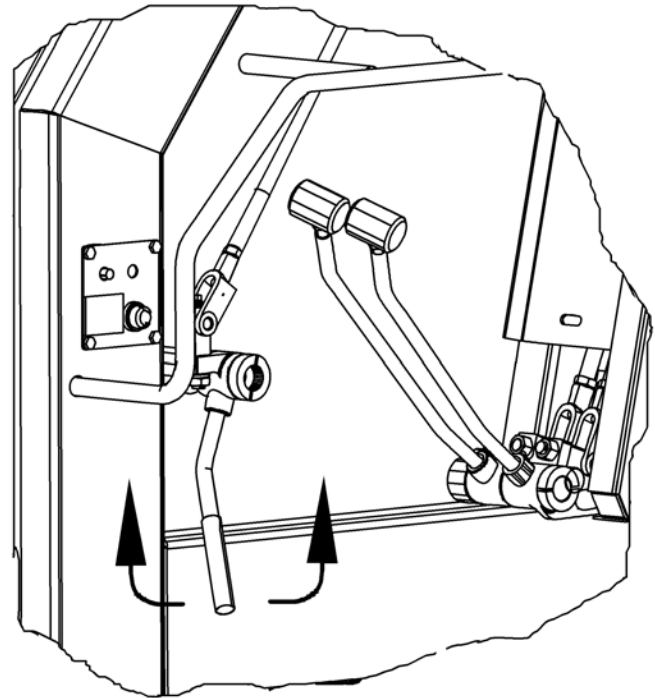

Figure 52. Cart Tipper Control Lever

## OPTIONAL OUTSIDE CONTROLS (CONTINUED)

### F. LATCH BAR ASSEMBLY

You use the latch bar assembly to secure a refuse container BEFORE you raise or lower the container with a reeving mechanism, winch or roll bar. Refer to the figure on the right.

1. You ROTATE the latch assemblies UP which RELEASES the latch bars and they can ROTATE DOWN.
2. You move the refuse container to the tailgate into position for latching its trunnion bar.
3. You ROTATE the latch bars UP and ROTATE the latch bar assemblies DOWN over the latch bars. This locks container's trunnion bar in the latch bar assembly.
4. A "bash bar" prevents the container from over-rotating into the hopper.

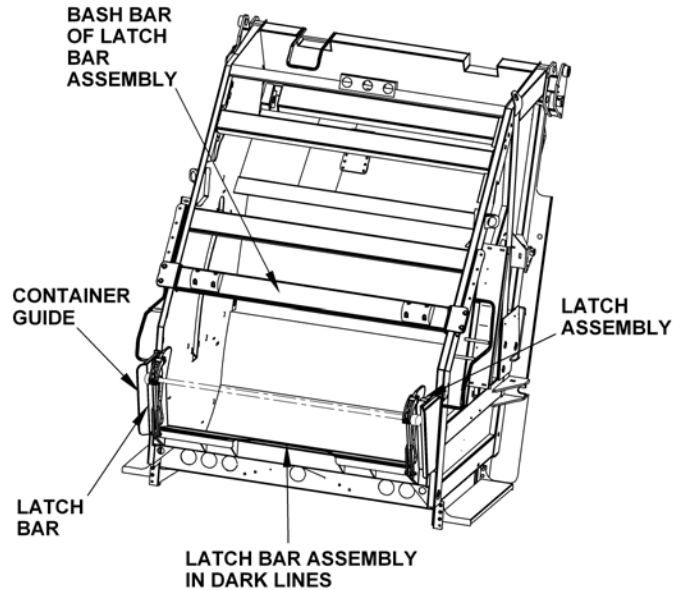

**Figure 53. Latch Bar Assembly**

# DURAPACK 5000

NOTES:

**SECTION 5**  
**BODY AND TAILGATE PROPS**

## PREVIEW

Read this section to learn about:

- Using the body props
- Using the tailgate props

## PROPPING THE BODY

There are no body props as you cannot raise the body of the unit since the unit is an eject model and not a dump model.

## PROPPING THE TAILGATE

**YOU MUST** prop the tailgate when you open it for service or maintenance. Use the instructions that follow and prop the tailgate with the factory-installed tailgate props.

Observe and obey the following DANGER and WARNING notices while you prop the tailgate with the factory tailgate props.

### **DANGER**

A tailgate is dangerous while you raise or lower it. A prop may fail and cause the tailgate to close suddenly which can result in serious injury or death if you become trapped between the tailgate and the body. Do not walk under or go between the body and the tailgate when the tailgate is in motion, while you prop the tailgate or while the tailgate is propped.

### Factory Tailgate Props

**YOU MUST USE BOTH** of the two support props at the rear of each unit whenever you open the tailgate for service or maintenance.

**MAKE SURE** the unit is on flat, stable ground and apply the parking brake and chock the wheels. There is a tailgate clamp (turnbuckle) on each side of the tailgate where the tailgate meets the body. See the figure below. Loosen the tailgate clamps (turnbuckles) enough to swing the clamps clear of the tailgate. Then follow the instructions on the Tailgate Prop Operation Decal on the unit (also shown on the next page).

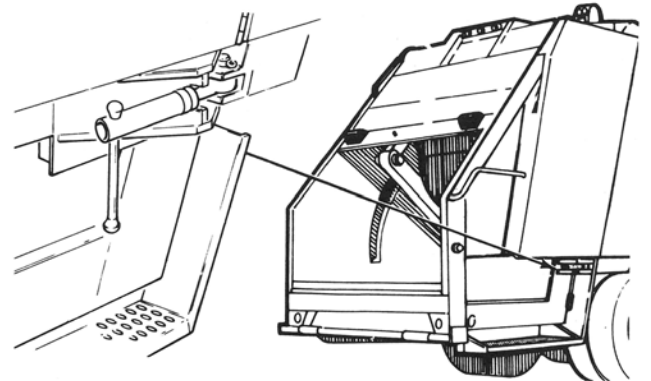

**Figure 54. Tailgate Clamps (Turnbuckles)**

## TAILGATE PROP OPERATION

**IMPORTANT: TAILGATE MUST BE FREE OF REFUSE AND ALL PERSONS CLEAR OF TAILGATE BEFORE PERFORMING THE FOLLOWING STEPS.**

**CAUTION**

**TWO PROPS ARE INSTALLED ON THE UNIT. BOTH MUST BE USED!**

### TO USE PROPS

2. Set unit on level surface and apply parking brake.
3. Loosen turnbuckle clamps. (Units with automatic tailgate locks do not use these clamps.)
4. Remove pins holding prop in stored bracket.
5. Raise tailgate to height where props can be rotated to support position.

6. Rotate props.
7. Lower tailgate until props mate with tailgate stop.
8. Turn engine off and remove ignition key.

### TO STORE PROPS

1. Raise tailgate slightly and rotate prop to stored position and install pin.
2. Lower tailgate completely and tighten turnbuckle clamps.

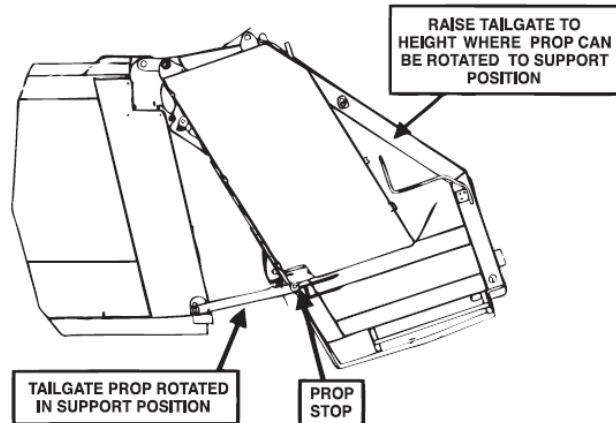

212-2791

**SECTION 6**  
**DAILY CHECKLIST**

# DURAPACK 5000

## DAILY CHECKLIST

Make sure you perform a daily check of the unit. Make copies of the **Refuse Vehicle Daily Inspection** <sup>961</sup> on the next several pages to have the Operator mark completed items before each route. Many checks in the Daily Checklist are maintenance related, such as checking tire pressures and hoses for wear and damage.

Refer to the **Daily Checklist Maintenance Items Chart** below for items to check and the required action.

DAILY CHECKLIST MAINTENANCE ITEMS	
Item	Required Action
Low air pressure in tires	Inflate the tire to the correct air pressure given on the tire
Worn tire	Replace when the wear is greater than allowed by law or before the tread is no longer visible
Damaged tire	Replace immediately BEFORE going on route.
Hydraulic pump leaks	Determine the cause of the leak and repair immediately.
Damaged hydraulic pump	Repair or replace IMMEDIATELY
Loose or missing hardware for the hydraulic pump	Tighten loose hardware Replace missing hardware immediately
Damaged decal or decal not readable	Replace decal immediately
Low level of hydraulic oil	Fill the hydraulic oil tank immediately
Worn or damaged hoses	Replace immediately
Leaks at cylinders, hoses or fittings.	Tighten loose connection
Loose or missing hardware	Tighten loose connections Replace missing hardware
Worn fiber guards	Replace hoses/fittings as necessary Install new fiber guard on new hoses
Worn or damaged tailgate lock components	Replace worn or damaged components
Loose or missing tailgate lock hardware	Tighten loose hardware Replace missing hardware

# DURAPACK 5000

<b>DAILY CHECKLIST MAINTENANCE ITEMS</b>	
<b>Item</b>	<b>Required Action</b>
Damaged tailgate seal	Replace seal
Body structure has loose or missing hardware	Tighten loose hardware Replace missing hardware
Body structure has cracked weld joints	Repair immediately
Body mounting brackets have loose hardware, damaged hardware or cracked welds	Tighten loose hardware Replace missing hardware Repair cracked welds
Air regulator (typically located at front of body)	90 PSI

# DURAPACK 5000



**REFUSE VEHICLE  
DAILY INSPECTION**

DATE: \_\_\_\_\_ / \_\_\_\_\_ / \_\_\_\_\_

UNIT NO. \_\_\_\_\_

Enter one of the following codes in the Inspection Results Code column:

Use a **√** to indicate inspected and no repair, service or adjustment is necessary.

Use an **R** to indicate repair, service or adjustment is necessary.

Use an **N** to indicate vehicle not equipped.

---

## **FOLLOW ALL APPLICABLE LOCK-OUT / TAG-OUT PROCEDURES**

Printed Name of Operator:

\_\_\_\_\_

I certify with the signature that follows that I performed a complete inspection in accordance with the following check list on the date given above.

Signature of Operator:

\_\_\_\_\_

Refer to **Preventative Maintenance Chart** <sup>159</sup> and **Lubrication Guide** <sup>163</sup> for additional information and requirements.

# DURAPACK 5000

CHECKS AND INSPECTIONS	INSPECTION RESULTS CODE (√/R/N)
<i>INSPECT PER APPLICABLE MANUFACTURER MANUAL</i>	
<b>Cab/Drive</b>	
<b>Wheels and Tires</b>	
<b>Tractor and Chassis Electrical</b>	
<b>Chassis</b>	
<b>Engine &amp; Transmission &amp; Fluid Levels</b>	
<b>Chassis Lubrication</b>	
<i>REFUSE COLLECTION SYSTEMS AND COMPONENTS</i>	
<b>CAB OUTSIDE AREA</b>	
Check air pressure of tires. Add air to any tire with air pressure lower than recommended before going on route.	
Check wear of tire tread. Replace tire worn below tire manufacturer's recommendation or state requirement before going on route.	
Check tires for damage. Replace any damaged tire before going on route.	
Inspect pump for leaks.	
Inspect pump for damage or loose hardware.	
Inspect all decals on cab for damage and readability.	
Inspect unit for refuse on or about the engine or exhaust components. <b>Remove all refuse to prevent a fire.</b>	
<b>BODY AND CHASSIS CURB SIDE INSPECTION</b>	

# DURAPACK 5000

<h2>CHECKS AND INSPECTIONS</h2>	<b>INSPECTION RESULTS CODE (√/R/N)</b>
Inspect level of hydraulic oil if tank is mounted on curb side. It must be full. <b>Add recommended oil as necessary.</b>	
Inspect body structure for damage, loose or missing nuts and bolts and for cracked welds and metal.	
Inspect body mounting brackets for cracked welds, missing bolts or nuts or movement.	
Inspect decals on curb side body for damage and readability.	
Inspect decals on body prop for damage and readability.	
Check air pressure of tires. Add air to any tire with air pressure lower than recommended before going on route.	
Check wear of tire treads. Replace any tire worn below tire manufacturer's recommendation or state requirement before going on route.	
Check tires for damage. Replace any damaged tire before going on route.	
Inspect tailgate raise components.	
Cylinder, hoses and fittings for leaks	
Hoses for wear and damage	
Cylinder for damage	
Loose or missing mounting hardware	
Inspect tailgate lock components	
Clamp components for wear and damage	
Loose or missing mounting hardware	
Make sure tailgate is locked	

# DURAPACK 5000

<b>CHECKS AND INSPECTIONS</b>	<b>INSPECTION RESULTS CODE (√/R/N)</b>
Right hand tailgate access cover is secured with quick disconnect pin AND wing screw	
<b>TAILGATE</b>	
Inspect decals on tailgate and underride bumper for damage and readability	
Inspect tailgate seal does not have visible damage	
Inspect underride bumper for damage and loose components.	
Inspect slide assembly	
Cylinders, hoses and fittings for leaks	
Hoses for wear and damage	
Cylinder for damage	
Loose or missing mounting hardware for hydraulics	
Loose or missing hardware for slide assembly	
Inspect packer panel	
Cylinders, hoses and fittings for leaks	
Hoses for wear and damage	
Cylinder for damage	
Loose or missing mounting hardware for hydraulics	
Loose or missing hardware for packer panel	
<b>BODY AND CHASSIS STREET SIDE INSPECTION</b>	

# DURAPACK 5000

100

<h2>CHECKS AND INSPECTIONS</h2>	<b>INSPECTION RESULTS CODE (√/R/N)</b>
Left hand tailgate door is secured with quick disconnect pin AND wing screw	
Make sure tailgate is locked.	
Inspect tailgate lock components.	
Clamp components for wear and damage	
Loose or missing mounting hardware	
Inspect tailgate raise components.	
Cylinder, hoses and fittings for leaks	
Hoses for wear and damage	
Cylinder for damage	
Loose or missing mounting hardware	
Check air pressure of tires. Add air to any tire with air pressure lower than recommended before going on route.	
Check wear of tire treads. Replace any tire worn below tire manufacturer's recommendation or state requirements before going on route.	
Check tires for damage. Replace any damaged tire before going on route	
Inspect all decals on street side body for damage and readability.	
Inspect body structure for damage, loose or missing nuts and bolts and for cracked welds.	
Inspect body mounting brackets for cracked weld, missing bolts or nuts or movement.	
Inspect level of hydraulic oil if tank is mounted on street side. It must be full. <b>Add recommended oil as necessary.</b>	

# DURAPACK 5000

<h2>CHECKS AND INSPECTIONS</h2>	<b>INSPECTION RESULTS CODE (√/R/N)</b>
Battery disconnect switch is turned to OFF then:	
Check wiring and battery cables from the battery box to the engine starter for wear and other damage. <b>IMMEDIATELY REPLACE WORN OR DAMAGED WIRING</b>	
Check wiring and cables for loose connections. <b>IMMEDIATELY TIGHTEN LOOSE CONNECTIONS</b>	
<b>OPERATION OF UNIT - <i>Skip this section if the unit will not be operated today</i></b>	
Make sure the air tank drain valve is closed.	
Turn battery disconnect to ON.	
Apply parking brake.	
Make sure the starter interlock operates – make sure unit will not start in gear.	
Start the engine.	
Indicator lights and gauges show normal operation of engine.	
Make sure the parking brake does not allow the vehicle to move forward or reverse at idle.	
Make sure the throttle advance (if equipped) operates only in neutral.	
Check all cab, body and tailgate lights for proper operation.	
Make sure the backup alarm and light operate.	
Make sure all people not necessary and any hazards are clear of the area and then:	
Operate the in-cab controls and make sure:	
If equipped, engage the PTO	

# DURAPACK 5000

<b>CHECKS AND INSPECTIONS</b>	<b>INSPECTION RESULTS CODE</b> (√/R/N)
PRESS the System Enable button – the button turns green and the PUMP is ON	
PRESS the System Enable button – the button turns gray and the PUMP is OFF	
PRESS the System Enable button – the button turns green and the PUMP is ON	
If equipped, The FILTER BYPASSED light is OFF. If not, and the filter was not changed before starting the unit, report this to your supervisor immediately. DO NOT go on route until the unit is repaired if the filter was not changed	
Operate all optional equipment switches and make sure the option operates correctly, such as a light	
Check the operation of all optional lights. Report any light that is ON and should be OFF or is OFF and should be ON	
Operate the standard outside controls located at the tailgate:	
At the same time, PUSH the SLIDE and SWEEP levers	
The SWEEP should move DOWN	
The slide should move IN	
At the same time, PULL the SLIDE and SWEEP levers	
The sweep should move UP	
The slide should move OUT	
Operate each installed optional outside control located at the tailgate:	
Reeving Mechanism	
Release the cable hook from it storage eye and hold the hook	

# DURAPACK 5000

103

<b>CHECKS AND INSPECTIONS</b>	<b>INSPECTION RESULTS CODE (√/R/N)</b>
PUSH the control lever – the cylinder should OUT (EXTEND)	
PULL the control lever – the cylinder should move IN (RETRACT)	
Attach the cable hook to its storage eye	
Winch	
Release the cable hook from its storage eye and hold the hook	
PUSH the control lever – the winch spool should UNWIND the cable from the spool	
PULL the control lever – the winch spool should WIND the cable on the spool	
Attach the cable hook to its storage eye	
Arm Mechanism	
PULL the control lever – the lift arms should RAISE	
PUSH the control lever – the lift arm should LOWER	
Make sure the arm mechanism is at the full LOWER position	
Roll Bar	
PULL the control lever – the roll bar should RAISE	
PUSH the control lever – the roll bar should LOWER	
Make sure the roll bar is at the full LOWER position	
Cart Tipper	
PULL the control lever – the cart tipper should RAISE	

# DURAPACK 5000

104

<b>CHECKS AND INSPECTIONS</b>	<b>INSPECTION RESULTS CODE (√/R/N)</b>
PUSH the control lever – the cart tipper should LOWER	
Make sure the cart tipper is at the full LOWER position	
PRESS the Buzzer – the in-cab alarm should sound	
Operate the standard outside controls located at the front, street side of body:	
If the body has refuse, do not operate the controls:	
If the body does not have refuse:	
PULL the tailgate lever and RAISE the tailgate sufficiently to set the tailgate props	
The RED TAILGATE OPEN (TG OPEN) light and alarm are ON	
Set the tailgate props	
Inspect the tailgate seal for damage	
Inspect the floor, ejector rails and ejector shoes	
Store the tailgate props and RAISE the tailgate completely	
PULL the ejector lever and FULLY EXTEND the ejector panel	
PUSH the ejector lever and FULLY RETRACT the ejector panel	
CLOSE the tailgate	
RED TAILGATE OPEN (TG OPEN) in-cab display indicator is OFF and the alarm is OFF; GREEN TAILGATE CLOSED (TG CLOSED) display indicator is ON	
Keep the engine running and continue the inspection	

# DURAPACK 5000

105

<b>CHECKS AND INSPECTIONS</b>	<b>INSPECTION RESULTS CODE (√/R/N)</b>
<b>IN-CAB INSPECTION</b>	
Inspect all in-cab decals for damage and readability.	
Make sure the following lights are OFF:	
RED TAILGATE OPEN (TG OPEN) in-cab display indicator is OFF and the alarm is OFF; GREEN TAILGATE CLOSED (TG CLOSED) display indicator is ON	
System Enable button is OFF – if it is ON, PRESS the System Enable button to turn OFF	
FILTER BYPASSED – if it is ON, REPLACE the filter BEFORE you go on route	
All other optional lights	
If equipped, check the operation of each camera.	
<b>FINAL INSPECTION</b>	
While you walk completely around the vehicle, look for:	
Fluid Leaks	
Cracked or damaged welds and metal	
Loose or missing bolts, nuts and clamps	

# DURAPACK 5000

NOTES:

**SECTION 7**  
**BEFORE GOING ON ROUTE**

## PREVIEW

Read this section to learn proper procedures for:

- Checking the unit each day
- Starting the unit in cold weather
- Setting the unit up for the route
- Removing power to the unit during periods of not using the unit

## BATTERY DISCONNECT SWITCH

The battery box is typically located on the streetside of the chassis frame near the front of the body, however it can be mounted at a different location on different chassis. Become familiar with the location of the battery box and battery disconnect switch on your unit.

1. You must turn the battery disconnect switch to the OFF position whenever the unit is shut off for any length of time – especially when the unit will be left unattended.
2. You must turn the battery disconnect switch to the ON position whenever you will use the unit.
3. You must check the position of the battery disconnect switch as part of the daily inspection.

### NOTICE

Battery cables must be securely anchored and not rubbing other equipment. Cable insulation must be free of damage and abrasion. Inspect weekly.

### NOTICE

Always disconnect the battery before welding on the chassis or body.

## DAILY CHECKLIST

See the **Daily Check section** <sup>93</sup> for the daily checks and procedures checklist. Make a copy of the check list.

### WARNING

A unit that needs service or repair can malfunction and create a dangerous condition. A part failure during operation can cause serious injury or death to a person or damage to the unit. Repair or replace any failed or defective part immediately.

## BEFORE STARTING A ROUTE

Before you start a route, do the following:

- Perform an inspection of the unit with the **Daily Checklist**<sup>93</sup>.
- Check the **Hydraulic Oil Level**.
- Cycle all **Hydraulic Functions**.
- If equipped, close the **Side Access Door**.
- Check the **“In-transit” Settings**<sup>114</sup>.

### Use the Daily Checklist to Inspect the Unit

It is the operator's responsibility to do a visual inspection of the unit and make sure the unit is in good operating condition before you start a route.

The requirements for the daily checks are given in the **Daily Checklist section**<sup>93</sup>. Make sure you complete the inspections on the checklist and you make all entries, including your signature.

## COLD WEATHER WARMUP PROCEDURE

When ambient air temperature is cold (below 0 degrees F), it is necessary to warm up the unit's hydraulic oil before you start your daily route operation or to check the oil level. The hydraulic oil is sufficiently warmed when the temperature is between 120° and 160°F.

### **WARNING**

Moving parts on the unit are dangerous. Serious injury or death can occur if a person is struck by the equipment. Clear all people from the area before you operate the unit

Follow the steps below to warm up the hydraulic oil.

1. START the TRUCK and let the engine idle.
2. APPLY the PARKING BRAKE and make sure it holds.
3. ENGAGE the HYDRAULIC PUMP for approximately five minutes.
4. MAKE SURE the AREA IS CLEAR of all unnecessary people BEFORE you operate the controls.
5. OPERATE the PACKER EXTEND and PACKER RETRACT functions through ten (10) cycles while the engine idles.
6. Make sure the oil temperature on the site gauge is between 120° and 160°F. If not, repeat step 5.
7. Check for fluid leaks. Repair if necessary.

## PREPARING THE UNIT TO CHECK THE HYDRAULIC OIL LEVEL

Before checking the oil level or adding oil, make sure the oil is warmed up and the unit is in the following position with all cylinders collapsed:

- Truck – on level ground
- Tailgate and Body – fully down and locked
- Ejector Panel – at the front of the body
- Packer Panel – in the in-transit position with all cylinders retracted

## CHECK HYDRAULIC OIL LEVEL

Check the hydraulic oil level (after warming up the oil) daily or every eight (8) hours, whichever comes first. Fill as necessary.

### Cycle All Hydraulic Functions

#### Follow These Steps:

1. Operate the packing panel, and body and tailgate functions two or three times each. See **Section 4**  for proper operation of controls.
2. Put the unit back in the position described above and check the oil level again.

3. Add oil if necessary. Refer to the Service Manual for instructions for filling the oil tank.

Current Heil standard hydraulic oil is **Shell Tellus S2 VX 32**. Please see product TDS and MSDS for more detail information about it. We strongly recommend to use it on Heil products to get best system performance and oil service life. Refer to the Service Manual for other approved hydraulic oils.

### NOTICE

Cold weather operation requires special oil considerations. Viscosity should not exceed 7500 SSU at lowest startup temperature. Continuous operation should range between 40–1000 SSU for all temperature ranges.

### NOTICE

Contamination is a hydraulic system's worst enemy. DO NOT let dirt enter the system. Use a clean rag and remove dirt or other contamination around any system component before you disconnect or remove it. While you fill the reservoir, filter the oil through a 200 mesh (or finer) screen. NEVER use a cloth to filter the oil.

# DURAPACK 5000

## HYDRAULIC OIL TANK WITH SIGHT GAUGE

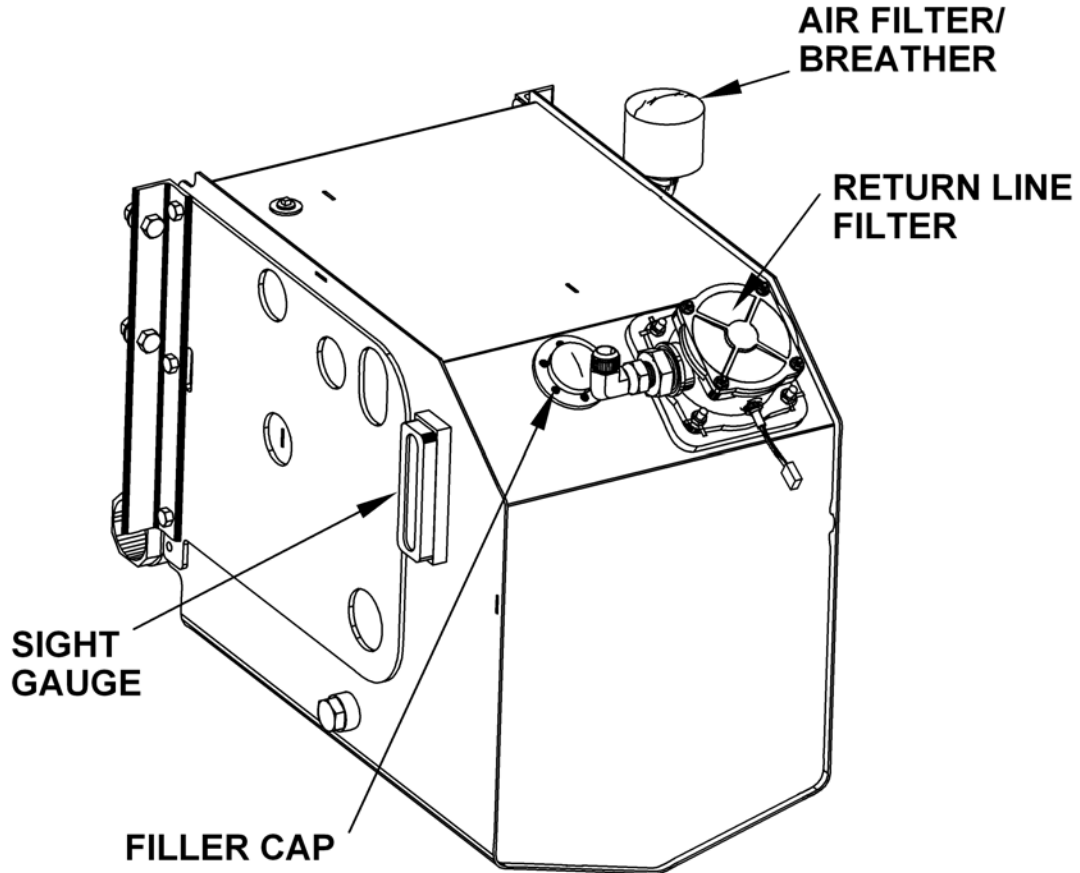

Figure 55. Hydraulic Oil Tank with Sight Gauge

## CYCLE ALL HYDRAULIC FUNCTIONS

Check the operation of all hydraulic controls on the unit. See **Section 4** for proper operation of controls.

### **WARNING**

Moving equipment can be dangerous to bystanders. Serious injury or death can occur if a person is in the wrong area or is not attentive to the operations. Clear the area of all unnecessary people before you operate the controls.

### **Perform These Steps:**

### **DANGER**

Your body or clothing can become caught by the packer blade while it moves. Serious injury or death may occur if a person is in or near the hopper when the packer blade and upper panel move. Clear the area near the hopper of all unnecessary people before you move the packer blade and upper panel and keep all parts of your body away from the packer blade.

#### 1. Upper Panel/Sweep Panel

Use the controls and **MOVE** the Upper Panel/Blade through at least one cycle of the start, sweep and pack positions.

### **DANGER**

A tailgate in motion is dangerous. Serious injury or death may occur if a person is struck by a moving tailgate or becomes trapped between the tailgate and the body. Clear the area near the tailgate of all unnecessary people before you lower the tailgate.

#### 2. Tailgate Raise Cycle

If the body is empty, do a tailgate **RAISE** and **LOWER** cycle. **DO NOT** raise the tailgate with refuse in the body or in the hopper.

### **DANGER**

Stand clear when the ejector panel is in motion. Keep side access door closed when ejector panel is in motion. Failure to obey may result in severe injury or death.

### **NOTICE**

Do not use the ejector panel to pack refuse against a closed tailgate (backpack). Packing refuse against a closed tailgate may result in damage to body or ejector cylinder.

#### 3. Ejector Panel

Do not operate the ejector panel if the body has refuse. When the body does not have refuse, **UNLOCK** and **RAISE** the tailgate, then do at least one **EJECTOR PANEL** cycle, which includes a full **EXTEND** cycle and a full **RETRACT** cycle.

## CHECK THE TRAVELING OR “IN-TRANSIT” POSITION

### NOTICE

BEFORE you drive any distance greater than one (1) mile or BEFORE you park a unit, you must make sure that the upper panel (slide) and sweep blade control levers are in the NEUTRAL position. If the control levers are not in the NEUTRAL position, heat may build up in the body hydraulics that could potentially cause damage to the unit.

When you travel to and from the landfill or transfer station, make sure the unit is in the in-transit mode as follows (see the figure to the right):

- The tailgate is fully LOWERED and CLOSED. Check the TAILGATE OPEN display indicator on the in-cab display. It must be GREEN (TG CLOSED).
- The tailgate clamps (turnbuckles) are tight and secure the tailgate.
- If equipped with a winch or reeving mechanism, the cable hook is secured in the eye on the tailgate.
- The left and right hand access doors are both closed and secured. For each door:
  - The quick release pin is secured in the barrel.
  - The wing screw is securely tightened against the door.

- For a unit with refuse, the blade is up tight against refuse. For a unit with no refuse, the blade is at the START POSITION.
- The ejector panel is at the front of the body.
- If equipped, the PTO is DISENGAGED.
- The System Enable button is OFF.
- You properly ADJUST and CLEAN the mirrors.
- All outside lights turn ON and OFF.
- If equipped, the side access door is CLOSED and LOCKED.

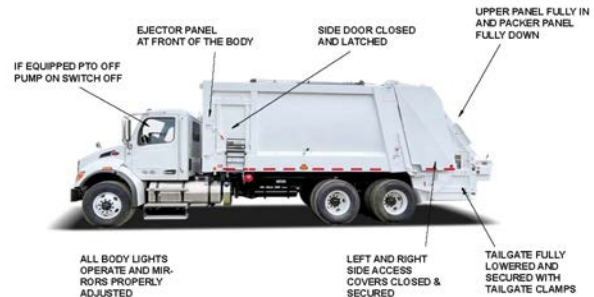

**Figure 56. In-Transit Position**

## CHECK THE TRAVELING OR “IN-TRANSIT” POSITION (CONTINUED)

## NOTES:

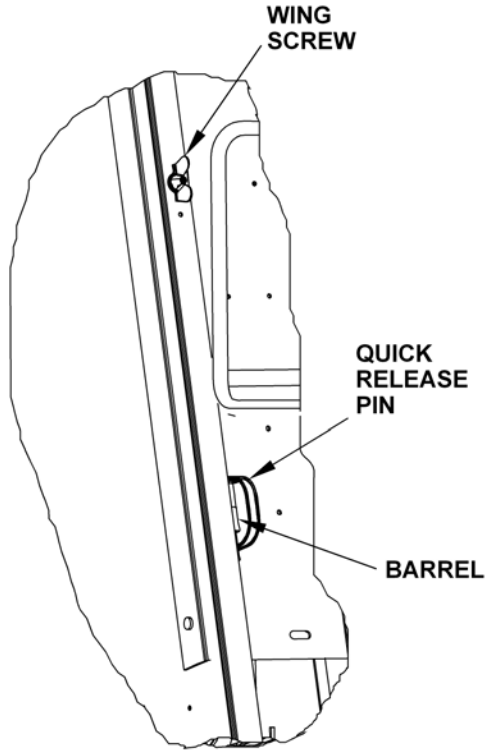

## DOOR DETAILS

Figure 57. In-Transit Position (Door  
Details)

# DURAPACK 5000

**NOTES:**

# **SECTION 8**

# **ON-ROUTE OPERATION PROCEDURES**

## PREVIEW

Read this section to learn about:

- Setting up the unit for a route
- Loading refuse
- Packing the load
- Packing on-the-move
- Washout system
- Setting up the unit for the landfill or transfer station

## DRIVING TO PICK-UP LOCATIONS

### NOTICE

BEFORE you drive any distance greater than one (1) mile or BEFORE you park a unit, you must make sure that the upper panel (slide) and sweep blade control levers are in the NEUTRAL position. If the control levers are not in the NEUTRAL position, heat may build up in the body hydraulics that could potentially cause damage to the unit.

Whenever you drive the unit to and from a route or to the landfill, make sure the refuse body is set up as follows:

- The tailgate is fully LOWERED and CLOSED. Check the TAILGATE OPEN display indicator on the in-cab display. It must be GREEN (TG CLOSED).
- The tailgate clamps (turnbuckles) are tight and secure the tailgate. Hydraulic tailgate locks (if equipped) are in the locked position and safety pins are in place.
- If equipped with a winch or reeving mechanism, the cable hook is secured in the eye on the tailgate.

- 
- The left and right hand service access doors are both closed and secured. For each door:
  - The quick release pin is secured in the barrel.
  - The wing screw is securely tightened against the door.
- For a unit with refuse, the blade is up tight against refuse. For a unit with no refuse, the blade is at the START POSITION.
- The ejector panel is at the front of the body.
- If equipped, the PTO is DISENGAGED.
- The System Enable button is OFF.
- You properly ADJUST and CLEAN the mirrors.
- All outside work lights turn OFF.
- If equipped, the body side access door is CLOSED and LATCHED.

### Use of Curb Side Drive

If equipped, drive from the curb-side driver position **ONLY** on the collection route. **DO NOT** use this station during travel to or from a route, landfill or transfer station.

## BEFORE LOADING

Before you start to load refuse, make sure the packing mechanism is in the correct position.

1. If equipped, the PTO is engaged. The System Enable button is ON.

## NOTICE

The ejector panel should never be used to “backpack” (operating the ejector extend function with the tailgate closed against trash in a fully or partially loaded unit). This can possibly result in damage to the unit including structural components and cylinder failure. The resulting damage will NOT be covered by warranty.

## DANGER

Stand clear when the ejector panel is in motion. Keep side access door closed when ejector panel is in motion. Failure to obey may result in severe injury or death.

2. The ejector panel should be:
  - a. For normal route pickup, about three (3) feet from the tailgate.
  - b. If starting with bulk refuse, the ejector panel should be about six (6) feet from the tailgate.
3. The packing mechanism should be in the START POSITION with the upper panel fully IN and the blade fully DOWN. See the figure 58.

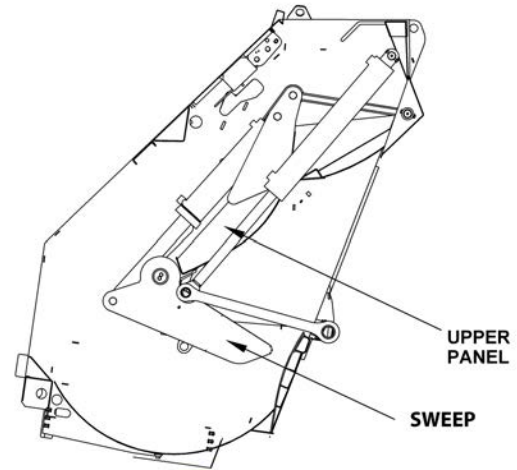

**Figure 58. Packer Blade Starting Position**

## LOADING REFUSE MANUALLY

Use the following procedures at each stop along the route to manually load refuse into the unit with the lift arm. Observe the DANGER and WARNING notices.

### DANGER

Your body or clothing can become caught by the sweep while it moves. Serious injury or death may occur if a person is in or near the hopper when the sweep and upper panel move. Clear the area near the hopper of all unnecessary people before you move the sweep and upper panel and keep all parts of your body away from the sweep.

1. Move the upper panel and sweep into the START position. See the figure to the left.
  - a. PUSH the upper panel and sweep levers at the same time and RELEASE the levers. The levers will self-center at the end of the commanded position by way of valve internal hydraulic pressure.
  - b. The upper panel will move IN and the sweep will move DOWN.
  - c. The hopper is now ready to receive refuse.
2. Load the refuse from a container into the hopper and then move the container to the pick-up location.

## Packing Refuse into the Body

### DANGER

The upper panel in/out and sweep up/down operations can push refuse out of the hopper or break objects. Refuse broken by the sweep can cause severe injury or death. Stand clear of the packer panel and to the side of the hopper when operating packing mechanism.

3. The In-Cab Packer Switch should be ON.
4. Make sure the tailgate is LOCKED.
5. Sweep the refuse from the hopper and pack it into the body.
  - a. PULL the upper panel and sweep levers at the same time and RELEASE the levers. The levers will self-center at the end of the commanded position by way of valve internal hydraulic pressure. See the figure below.

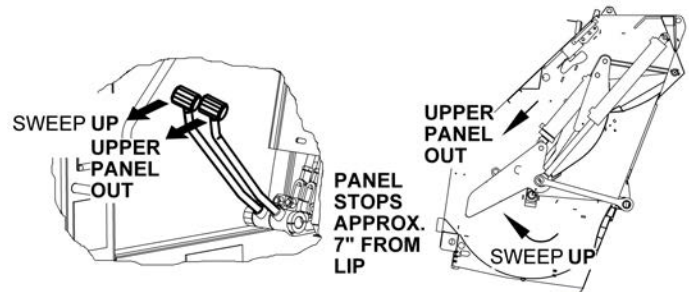
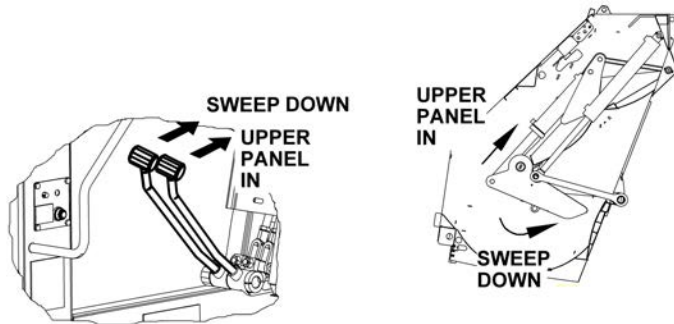

Figure 59. Loading Refuse

# DURAPACK 5000

## LOADING REFUSE MANUALLY (CONTINUED)

- b. The upper panel will move OUT and the blade will move UP. STOP the blade UP operation when the blade is at the pinch point with the hopper sill.
- c. Watch for refuse that is pushed out of the hopper.
- d. PUSH the upper panel and blade levers at the same time and RELEASE the levers. The levers will self-center at the end of the commanded position by way of valve internal hydraulic pressure. See the figure below.
- e. The upper panel and blade move and compact the refuse into the body.



**Figure 60. Packing the Refuse**

6. Repeat Steps 1 and 5 as necessary to compact the refuse.
7. Leave the blade against the refuse.
8. Move the refuse container to its pick-up location.

### **⚠ DANGER**

Do not use riding step when vehicle speed is more than 10 MPH or to travel more than 2 tenths (0.2) of a mile. Do not use riding step when vehicle operates in reverse. Always face vehicle when using riding step.

### **⚠ DANGER**

Do not ride on or in the hopper opening. Use riding step and obey all safety messages.

9. Each helper must PRESS the buzzer on their side of the tailgate and let the driver know each helper is ready to move to the next location.
10. Go to the next stop on the route.

### **⚠ WARNING**

Moving equipment can be dangerous. Serious injury or death may occur if a person is in the wrong area or is not attentive to the operations. Clear the area of all unnecessary people before you operate the controls.

## LOADING REFUSE WITH A REEVING MECHANISM

An option for Rear End Loaders (REs), a reeving mechanism is a cylinder assembly that is located on the centerline of the roof with which an operator can raise and dump a commercial refuse container.

The reeving mechanism hook and cable are not intended for any other purpose than dumping a Type T container into the hopper. The hook and cable should not be used for lifting, dragging, or manipulating containers, appliances, or other large items toward or into the hopper.

Use the instructions that follow to load refuse from a commercial refuse container into the hopper with a reeving mechanism.

Observe the DANGER and WARNING notices.

### DANGER

Your body or clothing can become caught by the blade while it moves. Serious injury or death may occur if a person is in or near the hopper when the blade and upper panel move. Clear the area near the hopper of all unnecessary people before you move the blade and upper panel and keep all parts of your body away from the blade.

### DANGER

Crush or Pinch Hazard.

Lifting or dragging uncontrolled items with hook and cable may cause items to move in a way that can pinch or crush the operator.

Cables from winches and reeving mechanisms are not designed to pull containers from mud or to move the container in any manner whatsoever.

Use winch or reeving cylinder hook and cable for dumping properly restrained ANSI Type T containers only. BOTH of the container trunnion bars must be fully engaged with the tailgate and securely latched into place.

Never use hook and cable for any other purpose.

Failure to comply may injure or kill.

### DANGER

The upper panel in/out and blade up/down operations can push refuse out of the hopper or break objects. Refuse broken by the blade can cause severe injury or death. Stand clear of the packer panel and to the side of the hopper when operating packing mechanism.

1. Move the upper panel and blade into the START POSITION. See **Figure 54** 
- a. PUSH the upper panel and blade levers at the same time and RELEASE the levers. The levers will self-center at the end of the commanded position by way of valve internal hydraulic pressure.

## LOADING REFUSE WITH A REEVING MECHANISM (CONTINUED)

- b. The upper panel will move IN and the blade will move DOWN.
  - c. The hopper is now ready to receive refuse.
2. Load the refuse from a container into the hopper. See **Figure 57**<sup>[122]</sup> and **Figure 58**<sup>[122]</sup>.
- a. Remove the reeving mechanism's cable hook from the eye on the tailgate.
  - b. PUSH the control lever for the reeving mechanism until you have sufficient cable to connect to the refuse bin.

### DANGER

A refuse container that is not in good condition with retaining washers in place may not be secured with the latch bar and can suddenly move. Death or serious injury can occur when a person is struck by a moving container that is not properly secured. Make sure the refuse container is properly secured to the latch bar before you raise or lower the container.

- c. Make sure the latch bar secures the container BEFORE you raise the container. See **Using a Latch Bar**<sup>[143]</sup>.

- d. PULL the control lever for the reeving mechanism until the reeving mechanism lifts the refuse container over the hopper sill and the refuse empties into the hopper. RELEASE the control lever. (If necessary, you can PRESS the Throttle Advance Switch during loading.)

When the refuse container's cover is not closed because it is overfilled with refuse:

- (1) Raise the container enough to empty part of the refuse from container into the hopper.
  - (2) Lower the container to the ground.
  - (3) Perform **Step 3**<sup>[126]</sup> (sweep the refuse and compact it into the hopper).
  - (4) Raise the container and finish emptying the container.
- e. After the refuse container is empty of refuse, PUSH the control lever for the reeving mechanism until the refuse bin rests firmly on the ground and there is enough slack in the cable to remove the cable hook from the refuse container.
  - f. Remove the cable hook and attach it to the eye on the tailgate.
  - g. PULL the control lever for the reeving mechanism until the cable tightens and secures the hook in the eye on the tailgate.

## LOADING REFUSE WITH A REEVING MECHANISM (CONTINUED)

- h. RELEASE the container's trunnion bar from the latch bar. See **Using a Latch Bar** <sup>143</sup>.
- i. MOVE the container to its pick-up location.

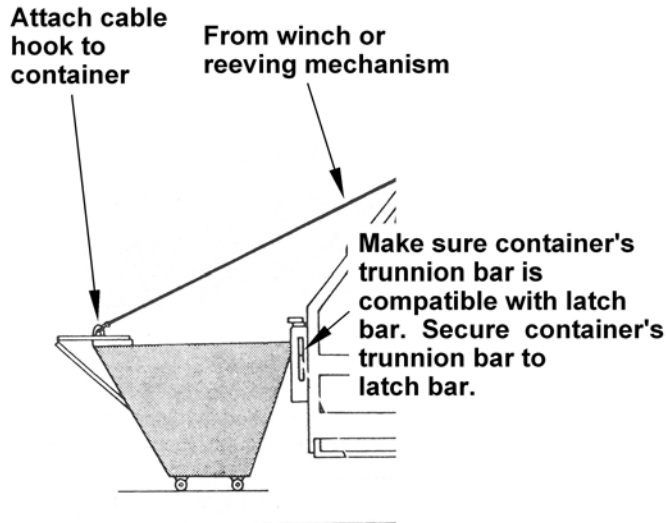
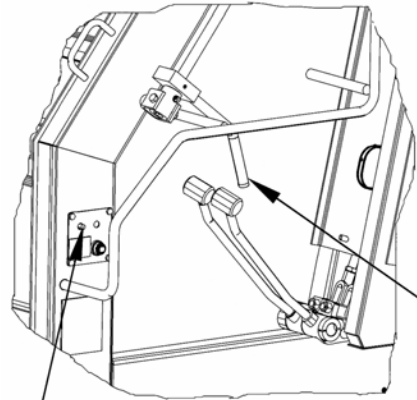
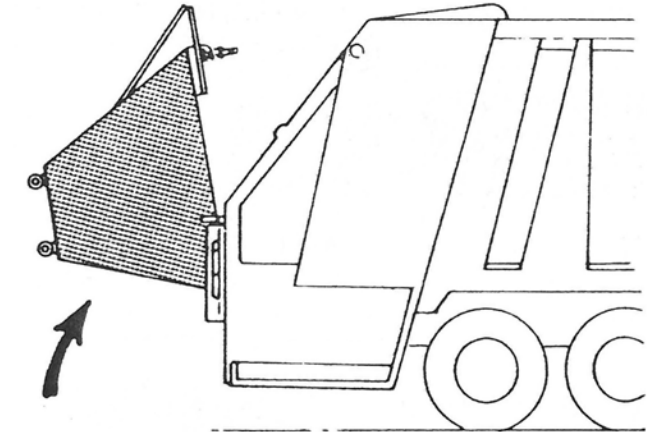

Figure 61. Reeving Mechanism or Winch Setup



THROTTLE ADVANCE SWITCH

PULL WINCH OR REEVING MECHANISM CONTROL LEVER AND PRESS THROTTLE ADVANCE SWITCH

Figure 62. Loading Refuse with Reeving Mechanism or Winch

# DURAPACK 5000

## LOADING REFUSE WITH A REEVING MECHANISM (CONTINUED)

### DANGER

Your body or clothing can become caught by the blade while it moves. Serious injury or death may occur if a person is in or near the hopper when the blade and upper panel move. Clear the area near the hopper of all unnecessary people before you move the blade and upper panel and keep all parts of your body away from the blade.

### DANGER

The upper panel in/out and blade up/down operations can push refuse out of the hopper or break objects. Refuse broken by the blade can cause severe injury or death. Stand clear of the packer panel and to the side of the hopper when operating packing mechanism.

3. Sweep the refuse from the hopper and pack it into the body.
  - a. PULL the upper panel and blade levers at the same time and RELEASE the levers. The levers will self-center at the end of the commanded position by way of valve internal hydraulic pressure. See **Figure 55** .
  - b. The upper panel will move OUT and the blade will move UP. STOP the blade UP operation when the blade is at the pinch point with the hopper sill.
  - c. Watch for refuse that is pushed out of the hopper.

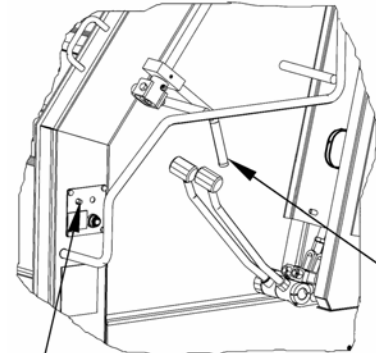
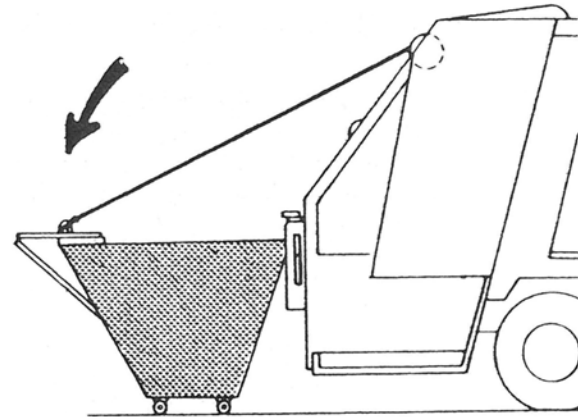

**THROTTLE ADVANCE SWITCH**

**PUSH WINCH OR REEVING MECHANISM CONTROL LEVER AND RELEASE THROTTLE ADVANCE SWITCH**

**Figure 63. Loading Refuse with Reeving Mechanism or Winch**

## LOADING REFUSE WITH A REEVING MECHANISM (CONTINUED)

- d. PUSH the upper panel and blade levers at the same time and RELEASE the levers. The levers will self-center at the end of the commanded position by way of valve internal hydraulic pressure. See **Figure 45** .
- e. The upper panel and blade move and compact the refuse into the body.
4. Repeat Steps 1 and 3 as necessary to compact the refuse.
5. Leave the blade against the refuse.

### **DANGER**

Do not use riding step when vehicle speed is more than 10 MPH or to travel more than 2 tenths (0.2) of a mile. Do not use riding step when vehicle operates in reverse. Always face vehicle when using riding step.

### **DANGER**

Do not ride on or in the hopper opening. Use riding step and obey all safety messages.

6. Each helper must PRESS the buzzer on their side of the tailgate and let the driver know each helper is ready to move to the next location.
7. Go to the next stop on the route.

# DURAPACK 5000

## LOADING REFUSE WITH A WINCH

An option for Rear End Loaders (REs), a winch is a mechanism with a hook and cable that an operator uses to raise, dump and lower a commercial refuse container

The winch hook and cable are not intended for any other purpose than dumping a Type T container into the hopper. The hook and cable should not be used for lifting, dragging, or manipulating containers, appliances, or other large items toward or into the hopper.

Use the instructions that follow to load refuse from a commercial refuse container into the hopper with a winch.

Observe the DANGER and WARNING notices.

### DANGER

Your body or clothing can become caught by the blade while it moves. Serious injury or death may occur if a person is in or near the hopper when the blade and upper panel move. Clear the area near the hopper of all unnecessary people before you move the blade and upper panel and keep all parts of your body away from the blade.

### DANGER

Crush or Pinch Hazard.

Lifting or dragging uncontrolled items with hook and cable may cause items to move in a way that can pinch or crush the operator.

Cables from winches and reeving mechanisms are not designed to pull containers from mud or to move the container in any manner whatsoever.

Use winch or reeving cylinder hook and cable for dumping properly restrained ANSI Type T containers only. BOTH of the container trunnion bars must be fully engaged with the tailgate and securely latched into place.

Never use hook and cable for any other purpose.

Failure to comply may injure or kill.

### DANGER

The upper panel in/out and blade up/down operations can push refuse out of the hopper or break objects. Refuse broken by the blade can cause severe injury or death. Stand clear of the packer panel and to the side of the hopper when operating packing mechanism.

## LOADING REFUSE WITH A WINCH (CONTINUED)

1. Move the upper panel and blade into the START POSITION. See **Figure 54**<sup>120</sup>.
  - a. PUSH the upper panel and blade levers at the same time and RELEASE the levers. The levers will self-center at the end of the commanded position by way of valve internal hydraulic pressure.
  - b. The upper panel will move IN and the blade will move DOWN.
  - c. The hopper is now ready to receive refuse.
2. Load the refuse from a container into the hopper. See **Figure 57**<sup>122</sup> and **Figure 58**<sup>122</sup>.
  - a. Remove the winch's cable hook from the eye on the tailgate.
  - b. PUSH the control lever for the winch until you have sufficient cable to connect to the refuse bin.

### **WARNING**

A refuse container that is not in good condition with retaining washers in place may not be secured with the latch bar and can suddenly move. Death or serious injury can occur when a person is struck by a moving container that is not properly secured. Make sure the refuse container is properly secured to the latch bar before you raise or lower the container.

- c. Make sure the latch bar secures the container **BEFORE** you raise the container. See **Using a Latch Bar**<sup>143</sup>.
- d. PULL the control lever for the winch until the refuse container lifts over the hopper sill and the refuse empties into the hopper. RELEASE the control lever. If necessary, you can PRESS the Throttle Advance Switch during loading.

When the refuse container's cover is not closed because it is overfilled with refuse:

- (1) Raise the container enough to empty part of the refuse from container into the hopper
- (2) Lower the container to the ground
- (3) Perform **Step 3**<sup>130</sup> (sweep the refuse and compact it into the hopper)
- (4) Raise the container and finish emptying the container.

## LOADING REFUSE WITH A WINCH (CONTINUED)

- e. After the refuse container is empty of refuse, PUSH the control lever for the winch until the refuse bin rests firmly on the ground and there is enough slack in the cable to remove the cable hook from the refuse container.
  - f. Remove the cable hook and attach it to the eye on the tailgate.
  - g. PULL the control lever for the winch mechanism until the cable tightens and secures the hook in the eye on the tailgate.
  - h. RELEASE the container's trunnion bar from the latch bar. See **Using a Latch Bar**<sup>[143]</sup>.
  - i. MOVE the container to its pick-up location.
  - j. Sweep the refuse from the hopper and pack it into the body.
3. Sweep the refuse from the hopper and pack it into the body.
    - a. PULL the upper panel and blade levers at the same time and RELEASE the levers. The levers will self-center at the end of the commanded position by way of valve internal hydraulic pressure. See **Figure 44**<sup>[122]</sup>.
    - b. The upper panel will move OUT and the blade will move UP. STOP the blade UP operation when the blade is at the pinch point with the hopper sill.
    - c. Watch for refuse that is pushed out of the hopper.
    - d. PUSH the upper panel and blade levers at the same time and RELEASE the levers. The levers will self-center at the end of the commanded position by way of valve internal hydraulic pressure. See **Loading Refuse Manually (Continued)**<sup>[122]</sup>.
  4. The upper panel and blade move and compact the refuse into the body.
  5. Repeat Steps 1 and 3 as necessary to compact the refuse.
  6. Leave the blade against the refuse.

## LOADING REFUSE WITH A WINCH (CONTINUED)

---

** DANGER**

---

Do not use riding step when vehicle speed is more than 10 MPH or to travel more than 2 tenths (0.2) of a mile. Do not use riding step when vehicle operates in reverse. Always face vehicle when using riding step.

---

** DANGER**

---

Do not ride on or in the hopper opening. Use riding step and obey all safety messages.

---

7. Each helper must PRESS the buzzer on their side of the tailgate and let the driver know each helper is ready to move to the next location.
8. Go to the next stop on the route.

## NOTES:

## LOADING REFUSE WITH AN ARM MECHANISM

An option for Rear End Loaders (RELs), an arm mechanism is an assembly that uses arms that mate with a refuse container's slots to lift, dump and lower a refuse container.

Use the instructions that follow to load refuse from a commercial refuse container into the hopper with an arm mechanism.

Observe the DANGER and WARNING notices.

### DANGER

Your body or clothing can become caught by the blade while it moves. Serious injury or death may occur if a person is in or near the hopper when the blade and upper panel move. Clear the area near the hopper of all unnecessary people before you move the blade and upper panel and keep all parts of your body away from the blade.

1. Move the upper panel and blade into the START position. See **Figure 43**<sup>120</sup>.
  - a. PUSH the upper panel and blade levers at the same time and RELEASE the levers. The levers will self-center at the end of the commanded position by way of valve internal hydraulic pressure.
  - b. The upper panel will move IN and the blade will move DOWN.
  - c. The hopper is now ready to receive refuse.

### CAUTION

A refuse container that is not in good condition may not be secured by the arm mechanism and can suddenly move. Minor or moderate injury can occur when a person is struck by a moving container that is not properly secured. Make sure the refuse container is properly secured to the arm mechanism before you raise or lower the container.

2. Load the refuse from a container into the hopper. See **Figure 44**<sup>122</sup> and **Figure 45**<sup>122</sup>.
  - a. Secure the refuse container to the arm mechanism.
  - b. PULL the control lever for the arm mechanism until the arm mechanism lifts the refuse container over the hopper sill and the refuse empties into the hopper. RELEASE the control lever. (If necessary, you can PRESS the Throttle Advance Switch during loading.)

When the refuse container's cover is not closed because it is overfilled with refuse:

- (1) Raise the container enough to empty part of the refuse from container into the hopper.
- (2) Lower the container to the ground.
- (3) Perform **Step 3**<sup>134</sup> (sweep the refuse and compact it into the hopper).
- (4) RAISE the container and finish emptying the container.

## LOADING REFUSE WITH AN ARM MECHANISM (CONTINUED)

- c. After the refuse container is empty of refuse, PUSH the control lever for the arm mechanism until the refuse bin rests firmly on the ground. (RELEASE the Throttle Advance Switch if you pressed it during loading.)
- d. RELEASE the container from the arm mechanism.
- e. PULL the control lever for the arm mechanism until the arms are fully up and folded.
- f. MOVE the container to its pick-up location.

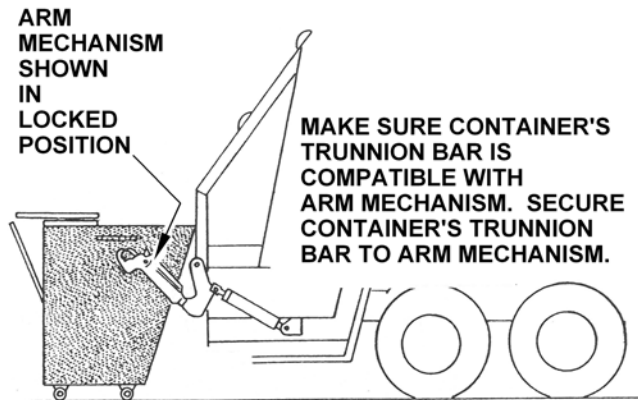

Figure 64. Arm Mechanism Setup

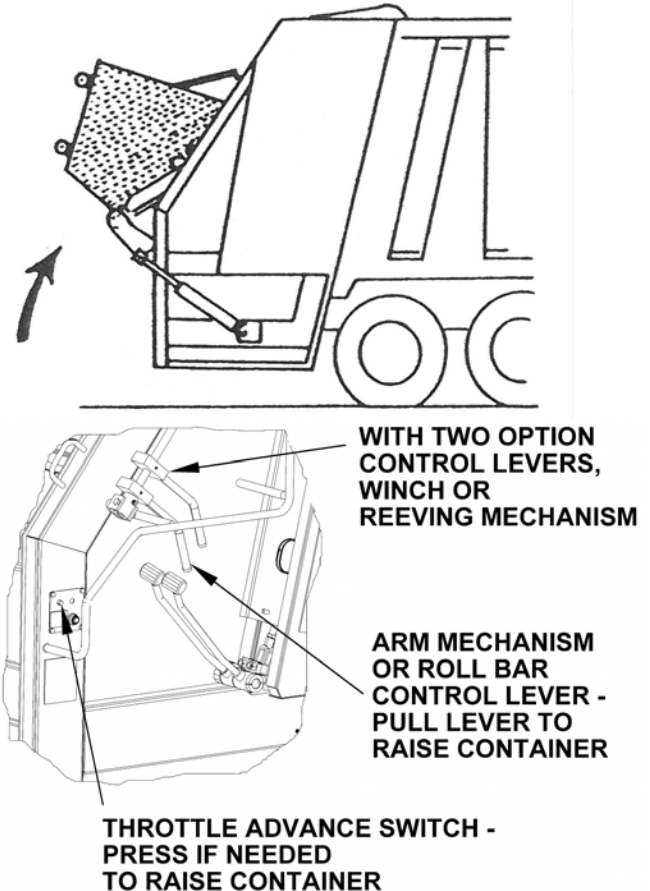

Figure 65. Loading Refuse with Arm Mechanism

## LOADING REFUSE WITH AN ARM MECHANISM (CONTINUED)

### **⚠ DANGER**

Your body or clothing can become caught by the blade while it moves. Serious injury or death may occur if a person is in or near the hopper when the blade and upper panel move. Clear the area near the hopper of all unnecessary people before you move the blade and upper panel and keep all parts of your body away from the blade.

### **⚠ DANGER**

The upper panel in/out and blade up/down operations can push refuse out of the hopper or break objects. Refuse broken by the blade can cause severe injury or death. Stand clear of the packer panel and to the side of the hopper when operating packing mechanism.

3. Sweep the refuse from the hopper and pack it into the body.
  - a. PULL the upper panel and blade levers at the same time and RELEASE the levers. The levers will self-center at the end of the commanded position by way of valve internal hydraulic pressure. See **Loading Refuse Manually (Continued)** <sup>122</sup>.
  - b. The upper panel will move OUT and the blade will move UP. STOP the blade UP operation when the blade is at the pinch point with the hopper sill.

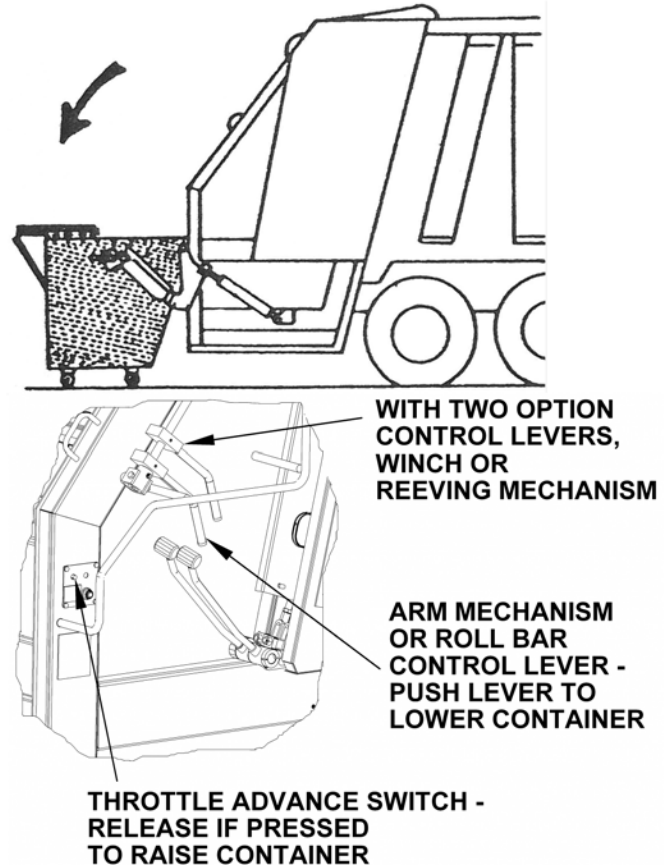

Figure 66. Loading Refuse with Arm Mechanism

## LOADING REFUSE WITH AN ARM MECHANISM (CONTINUED)

- c. Watch for refuse that is pushed out of the hopper.
  - d. PUSH the upper panel and blade levers at the same time and RELEASE the levers. The levers will self-center at the end of the commanded position by way of valve internal hydraulic pressure. See **Figure 45**<sup>122</sup>.
  - e. The upper panel and blade move and compact the refuse into the body.
4. Repeat Steps 1 and 3 as necessary to compact the refuse.
  5. Leave the blade against the refuse.

### DANGER

Do not use riding step when vehicle speed is more than 10 MPH or to travel more than 2 tenths (0.2) of a mile. Do not use riding step when vehicle operates in reverse. Always face vehicle when using riding step.

### DANGER

Do not use an arm mechanism or roll bar as a riding step. Obey safety messages and use the riding step for when traveling on the unit. Serious injury or death may occur.

### DANGER

Do not ride on or in the hopper opening. Use riding step and obey all safety messages.

6. Each helper must PRESS the buzzer on their side of the tailgate and let the driver know each helper is ready to move to the next location.
7. Go to the next stop on the route.

## LOADING REFUSE WITH A ROLL BAR MECHANISM

An option for Rear End Loaders (RELs), a Roll Bar Mechanism is an assembly that uses a bar to lift, dump and lower a residential refuse bin.

Use the instructions that follow to load refuse from a commercial refuse container into the hopper with a roll bar mechanism.

Observe the DANGER and WARNING notices.

### DANGER

Your body or clothing can become caught by the blade while it moves. Serious injury or death may occur if a person is in or near the hopper when the blade and upper panel move. Clear the area near the hopper of all unnecessary people before you move the blade and upper panel and keep all parts of your body away from the blade.

1. Move the upper panel and blade into the START position. See **Figure 43**<sup>120</sup>.
  - a. PUSH the upper panel and blade levers at the same time and RELEASE the levers. The levers will self-center at the end of the commanded position by way of valve internal hydraulic pressure.
  - b. The upper panel will move IN and the blade will move DOWN.
  - c. The hopper is now ready to receive refuse.

2. Load the refuse from a container into the hopper. See **Figure 44**<sup>122</sup> and **Figure 45**<sup>122</sup>.
  - a. Set the refuse container in front of the roll bar until the container touches or nearly touches the roll bar.

### CAUTION

A refuse container that is not in good condition with retaining washers in place may not be secured with the latch bar and can suddenly move. Minor or moderate injury can occur when a person is struck by a moving container that is not properly secured. Make sure the refuse container is properly secured to the latch bar before you raise or lower the container.

- b. Make sure the latch bar secures the container BEFORE you raise the container. See **Using a Latch Bar**<sup>143</sup>.
- c. PULL the control lever for the roll bar mechanism until the roll bar lifts the refuse container lifts over the hopper sill and the refuse empties into the hopper. RELEASE the control lever.

### WARNING

Do not use roll bar to bounce refuse container in order to empty the container. Bouncing the container with the roll bar may disengage or break the container's trunnion bar. Death or serious injury can occur when a person is struck by a moving container that is not properly secured. Make sure the refuse container is properly secured to the latch bar before you raise or lower the container.

## LOADING REFUSE WITH A ROLL BAR MECHANISM (CONTINUED)

- d. When the refuse container's cover is not closed because it is overfilled with refuse:
  - o Raise the container enough to empty part of the refuse from container into the hopper.
  - o Lower the container to the ground.

### **DANGER**

The upper panel in/out and blade up/down operations can push refuse out of the hopper or break objects. Refuse broken by the blade can cause severe injury or death. Stand clear of the packer panel and to the side of the hopper when operating packing mechanism.

- o Perform Step 3 (sweep the refuse and compact it into the hopper).
- o RAISE the container and finish emptying the container.
- e. After the refuse container is empty of refuse, PUSH the control lever for the roll bar mechanism until the refuse bin rests firmly on the ground and you can release the latch bar.
- f. RELEASE the container's trunnion bar from the latch bar. See **Using a Latch Bar**<sup>143</sup>.
- g. RELEASE the container from the roll bar mechanism.

- h. MOVE the container to its pick-up location.
3. Sweep the refuse from the hopper and pack it into the body.
  - a. PULL the upper panel and blade levers at the same time and RELEASE the levers. The levers will self-center at the end of the commanded position by way of valve internal hydraulic pressure. See **Loading Refuse Manually (Continued)**<sup>122</sup>.
  - b. The upper panel will move OUT and the blade will move UP. STOP the blade UP operation when the blade is at the pinch point with the hopper sill.
  - c. Watch for refuse that is pushed out of the hopper.
  - d. PUSH the upper panel and blade levers at the same time and RELEASE the levers. The levers will self-center at the end of the commanded position by way of valve internal hydraulic pressure. See **Loading Refuse Manually (Continued)**<sup>122</sup>.
  - e. The upper panel and blade move and compact the refuse into the body.
4. Repeat Steps 1 and 3 as necessary to compact the refuse.

## LOADING REFUSE WITH A ROLL BAR MECHANISM (CONTINUED)

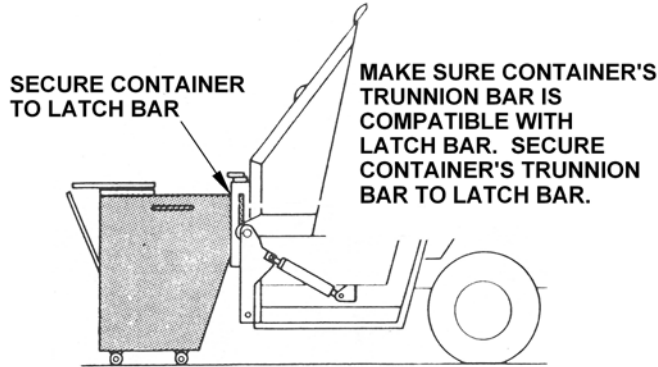

Figure 67. Roll Bar Setup

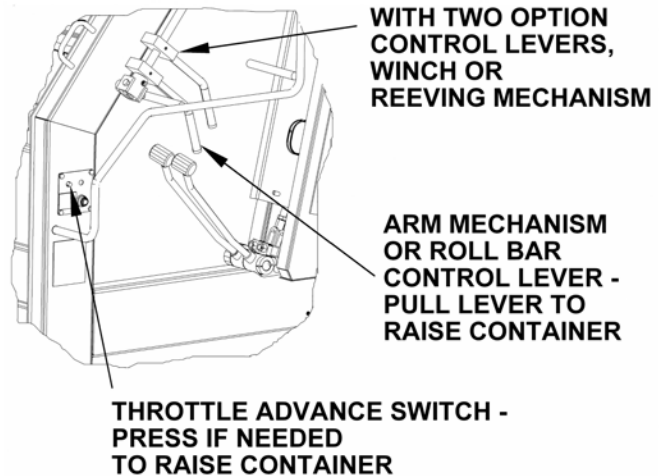
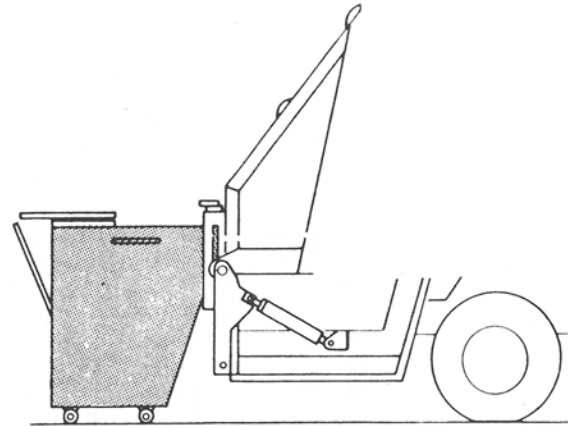

Figure 68. Loading Refuse with Roll Bar

## LOADING REFUSE WITH A ROLL BAR MECHANISM (CONTINUED)

5. Leave the blade against the refuse.

### DANGER

Do not use riding step when vehicle speed is more than 10 MPH or to travel more than 2 tenths (0.2) of a mile. Do not use riding step when vehicle operates in reverse. Always face vehicle when using riding step.

### DANGER

Do not use an arm mechanism or roll bar as a riding step. Obey safety messages and use the riding step for when traveling on the unit. Serious injury or death may occur.

### DANGER

Do not ride on or in the hopper opening. Use riding step and obey all safety messages.

6. Each helper must PRESS the buzzer on their side of the tailgate and let the driver know each helper is ready to move to the next location.
7. Go to the next stop on the route.

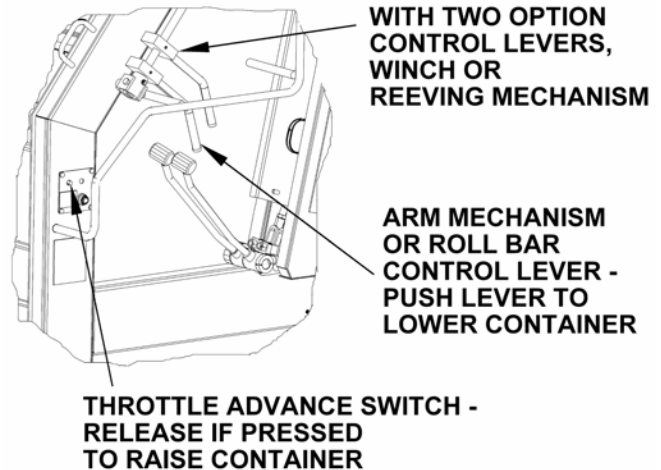
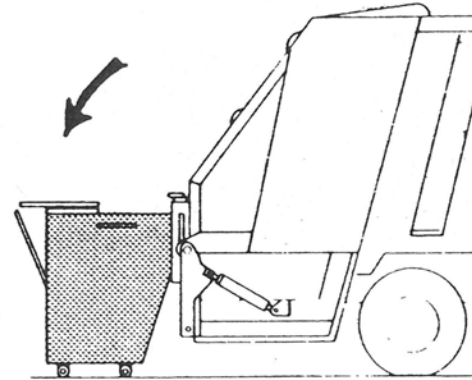

Figure 69. Loading Refuse with a Roll Bar

## LOADING REFUSE WITH A CART TIPPER

A cart tipper is a Rear End Loader (REL) option attached to the tailgate that allows an operator to secure a residential refuse container and unload its contents into the hopper.

Use the instruction that follow to load refuse from a commercial refuse container into the hopper with a cart tipper. See the figure to the right for the location of the cart tipper control lever.

Observe the DANGER and WARNING notices.

### DANGER

Your body or clothing can become caught by the sweep while it moves. Serious injury or death may occur if a person is in or near the hopper when the sweep and upper panel move. Clear the area near the hopper of all unnecessary people before you move the sweep and upper panel and keep all parts of your body away from the sweep.

1. Move the upper panel and sweep into the START position. See **Figure 43**<sup>[120]</sup>.
  - a. PUSH the upper panel and sweep levers at the same time and RELEASE the levers. The levers will self-center at the end of the commanded position by way of valve internal hydraulic pressure.
  - b. The upper panel will move IN and the sweep will move DOWN.
  - c. The hopper is now ready to receive refuse.

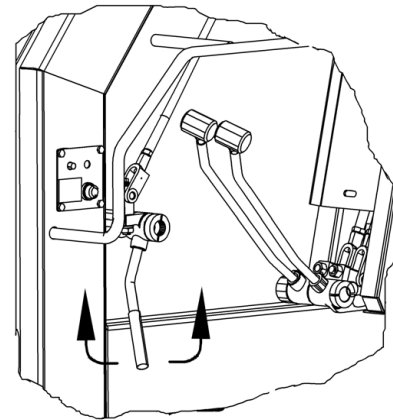

**Figure 70. Cart Tipper Control Lever**

2. Load the refuse from a container into the hopper. See **Figure 44**<sup>[122]</sup> and **Figure 45**<sup>[122]</sup>. Set the refuse container in front of the cart tipper until the container latch bar is over the cart tipper saddle.

### CAUTION

A refuse container that is not in good condition may not be secured by the cart tipper's latch and can suddenly move. Minor or moderate injury can occur when a person is struck by a moving container that is not properly secured. Make sure the refuse container is properly secured to the cart tipper before you raise or lower the container.

## LOADING REFUSE WITH A CART TIPPER (CONTINUED)

- a. PULL the control lever for the cart tipper until the refuse container lifts over the hopper sill and the refuse empties into the hopper. RELEASE the control lever.

When the refuse container's cover is not closed because it is overfilled with refuse:

- Raise the container enough to empty part of the refuse from container into the hopper.
- MAKE SURE the cart tipper upper panel latch extends and LOCKS the container when you RAISE the container.
- If the latch does not extend, lower the container, make sure the container latch bar is over the cart tipper saddle and RAISE the container again. DO NOT continue to RAISE a refuse container when the upper panel latch does not extend and lock the container.
- Lower the container to the ground.

### DANGER

Your body or clothing can become caught by the sweep while it moves. Serious injury or death may occur if a person is in or near the hopper when the sweep and upper panel move. Clear the area near the hopper of all unnecessary people before you move the sweep and upper panel and keep all parts of your body away from the sweep.

### DANGER

The upper panel in/out and sweep up/down operations can push refuse out of the hopper or break objects. Refuse broken by the sweep can cause severe injury or death. Stand clear of the packer panel and to the side of the hopper when operating packing mechanism.

- Perform **Step 3**  (sweep the refuse and compact it into the hopper).
  - Raise the container and finish emptying the container.
- b. After the refuse container is empty of refuse, PUSH and RELEASE the control lever for the cart tipper. The cart tipper will LOWER the refuse bin to the ground.
  - c. If the cart tipper does not operate at the speed given on the tipper or in the cart tipper Operator's Manual, refer to the tipper's Service Manual or call the manufacturer.
  - d. Release the refuse container from the cart tipper.
  - e. Move the container to its pick-up location.

## LOADING REFUSE WITH A CART TIPPER (CONTINUED)

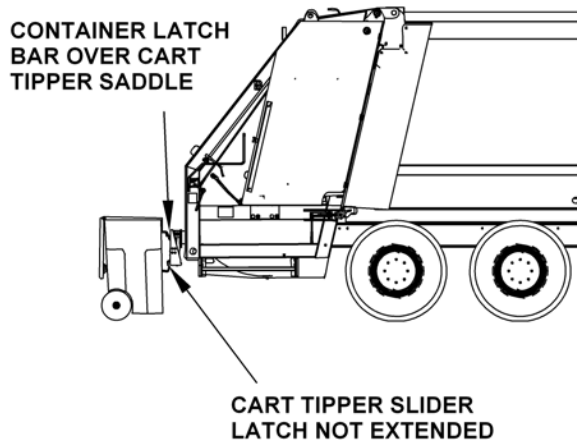

**Figure 71. Cart Tipper Setup**

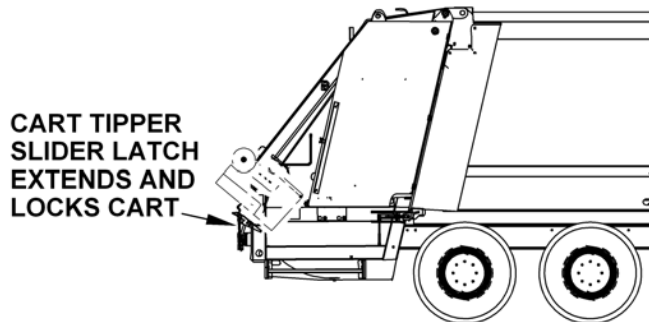

**Figure 72. Loading Refuse with Cart Tipper**

### **⚠ DANGER**

Your body or clothing can become caught by the sweep while it moves. Serious injury or death may occur if a person is in or near the hopper when the sweep and upper panel move. Clear the area near the hopper of all unnecessary people before you move the sweep and upper panel and keep all parts of your body away from the sweep.

### **⚠ DANGER**

The upper panel in/out and sweep up/down operations can push refuse out of the hopper or break objects. Refuse broken by the sweep can cause severe injury or death. Stand clear of the packer panel and to the side of the hopper when operating packing mechanism.

3. Sweep the refuse from the hopper and pack it into the body.
  - a. PULL the upper panel and sweep levers at the same time and RELEASE the levers. The levers return to their center position. See **Figure 44**<sup>122</sup>.
  - b. The upper panel will move OUT and the sweep will move UP. STOP the sweep UP operation when the sweep is at the pinch point with the hopper sill.
  - c. Watch for refuse that is pushed out of the hopper.

## LOADING REFUSE WITH A CART TIPPER (CONTINUED)

- d. PUSH the upper panel and sweep levers at the same time and RELEASE the levers. The levers will self-center at the end of the commanded position by way of valve internal hydraulic pressure. See **Figure 45**<sup>[122]</sup>.
  - e. The upper panel and sweep move and compact the refuse into the body.
4. Repeat Steps 1 and 3 as necessary.
  5. Leave the sweep against the refuse.

### DANGER

Do not use riding step when vehicle speed is more than 10 MPH or to travel more than 2 tenths (0.2) of a mile. Do not use riding step when vehicle operates in reverse. Always face vehicle when using riding step.

### DANGER

Do not ride on or in the hopper opening. Use riding step and obey all safety messages.

6. Each helper must PRESS the buzzer on their side of the tailgate and let the driver know each helper is ready to move to the next location.
7. Go to the next stop on the route.

## USING A LATCH BAR

The latch bar is an assembly and its major components are two latch assemblies, two latch bars, two container guides and a bash bar. **Figure 58**<sup>[144]</sup> shows the latch bar's components rotated down, that is ready to accept a refuse container. **Figure 59**<sup>[144]</sup> shows the latch bar's components rotated up when it locks a container.

### WARNING

Do not use a refuse container that does not have a compatible trunnion bar. If the trunnion bar is not compatible with the latch bar, the refuse container may not lock properly with the latch bar assembly. Cables should only be used when BOTH of the container trunnion bars are fully engaged with the tailgate and securely latched into place. Death or serious injury may occur when the latch bar cannot properly lock a container's trunnion bar.

1. Before you move the refuse container, ROTATE the latch assemblies UP which releases the latch bars. See **Figure 58**<sup>[122]</sup>.
2. Move the container so that the ends of its trunnion bar are on the outside of the two latch bars. The container guides will help you with this alignment. The container guides are angled away from the tailgate.
3. ROTATE the latch bars UP and ROTATE the latch bar assemblies DOWN over the two latch bars. This locks the container's trunnion bar for lifting and lowering operations. See **Figure 59**<sup>[122]</sup>.
4. The bash bar prevents the container from over-rotating into the hopper.

## USING A LATCH BAR (CONTINUED)

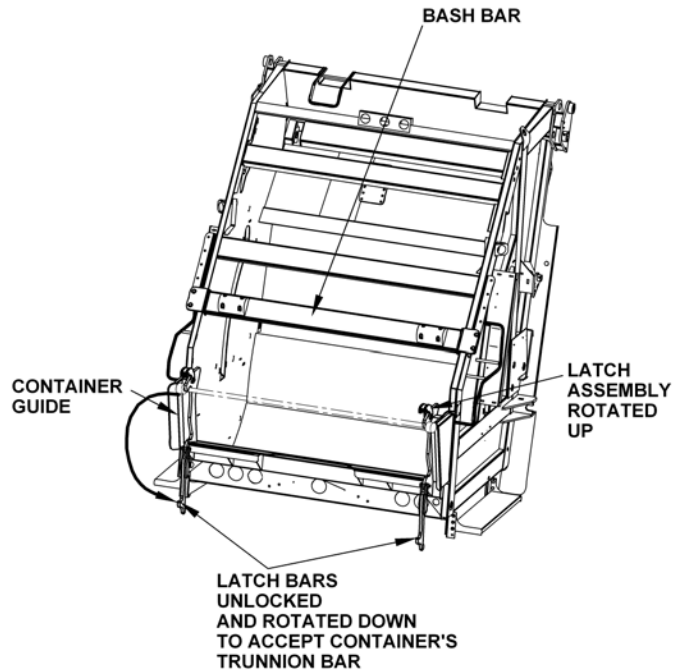

**Figure 73. Latch Bars Rotated Down**

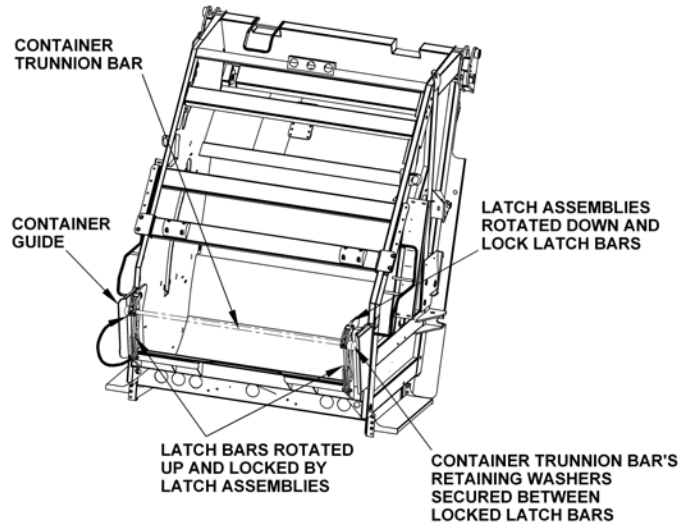

**Figure 74. Latch Bars Rotated Up**

# DURAPACK 5000

## PACKING ON-THE-MOVE

Heil DuraPack 5000 units can pack on-the move. The operator does this manually while on the riding step (if equipped) between stops. Some units will not do this because of transmission options or customer-specified configurations. Contact Customer Support at 866-275-4345 for more information about these units.

### **DANGER**

Use only the riding step provided to travel on the outside of the unit during collection activities. Use hand holds provided and maintain at least 3 points of contact. Failure to obey these instructions can result in serious injury or death.

### **DANGER**

Do not use riding step when vehicle speed is more than 10 MPH or to travel more than 2 tenths (0.2) of a mile. Do not use riding step when vehicle operates in reverse. Always face vehicle when using riding step.

## ACHIEVING PAYLOADS

Read this section for advice and tips on how to pack the most efficient loads with your unit.

Payloads in any refuse/waste handling vehicle will vary greatly, depending on the type of material loaded. Dry bulk cardboard and reconstruction/building materials, Styrofoam, foam packing materials, loose plastic, etc. cannot be compressed and packed as effectively as wet, soft, garbage type materials. If dry materials can be mixed with some wet material, more effective payloads can be achieved.

Follow these techniques to attain greater efficiency in packing the load in your unit:

1. After you empty the first few bins, the body begins to fill and material can begin to “fall back” into the hopper
2. If the route allows, mix some wet bins in with dry bins. This helps compact the dry material more. Wet material also helps lubricate the body, which results in better packing.

## LEAVING THE ROUTE FOR THE LANDFILL/ TRANSFER STATION

At the end of the route, or when the unit has a full load, prepare the unit to go to the landfill. See **Driving to Pick-up Locations** <sup>119</sup> and make sure the unit is properly set up for travel.

- The tailgate is fully LOWERED and CLOSED. Check the TAILGATE OPEN display indicator on the in-cab display. It must be GREEN (TG CLOSED).
- The tailgate clamps (tumbuckles) are tight and secure the tailgate.
- If equipped with a winch or reeving mechanism, the cable hook is secured in the eye on the tailgate.
- The left and right hand access doors are both closed and secured. For each door:
  - The quick release pin is secured in the barrel.
  - The wing screw is securely tightened against the door.

- For a unit with refuse, the blade is up tight against refuse. For a unit with no refuse, the blade is at the START POSITION.
- The ejector panel is at the front of the body.
- If equipped, the PTO is DISENGAGED.
- The System Enable button is OFF.
- You properly ADJUST and CLEAN the mirrors.
- All outside lights turn ON and OFF.
- If equipped, the side access door is CLOSED and LOCKED.

**SECTION 9  
LANDFILL/TRANSFER STATION/  
RECYCLE CENTER PROCEDURES**

## PREVIEW

Read this section to learn about:

- Setup conditions to dump the refuse
- Unloading the refuse
- Using the sump and (optional) washout system
- Preparing the unit to return to route.

## OVERVIEW OF LANDFILL/TRANSFER STATION/RECYCLE CENTER PROCEDURES

Use the following information as an overview of the steps to follow when you unload a load of refuse at the landfill.

For each step in this overview, read and follow the detailed instructions that follow the overview:

1. Set the unit in position for unloading.
2. Unlock and fully RAISE the tailgate.
3. Fully EXTEND the EJECTOR panel.
4. Fully LOWER and secure the tailgate.
5. Prepare the unit to return to the route.

### NOTICE

The location of the controls on your unit may be different than those shown in this manual. Make sure you know your unit's control pattern before you operate the the unit.

## SETTING UP THE UNIT FOR UNLOADING

After you position the unit on firm ground for unloading at the landfill, set it up properly before dumping the refuse.

### Follow These Steps:

1. Some suspensions allow more movement in the chassis than others. Always stop the unit on the most stable, hard, dry and level surface you can find before you empty the refuse.

2. Shift the transmission to NEUTRAL.
3. Apply work brake so the pump engages
4. MOVE the in-cab switch to activate pump.
5. If there is refuse in the hopper, cycle the blade until the hopper is clear of refuse.

## UNLOADING REFUSE

### A. Unlocking and Raising the Tailgate

#### DANGER

A tailgate in motion is dangerous. Serious injury or death may occur if a person is struck by a moving tailgate or becomes trapped between the tailgate and the body. Clear the area near the tailgate of all unnecessary people before you lower the tailgate.

1. REMOVE TAILGATE safety pins.
2. PULL the TAILGATE lever UP and HOLD.
3. Apply work brake so the pump engages
4. MOVE the in-cab switch to activate pump.

## UNLOADING REFUSE (CONTINUED)

### A. Unlocking and Raising the Tailgate (Continued)

3. HOLD the lever until the tailgate is COMPLETELY raised.
4. RELEASE the TAILGATE LEVER and the THROTTLE ADVANCE switch.

### NOTICE

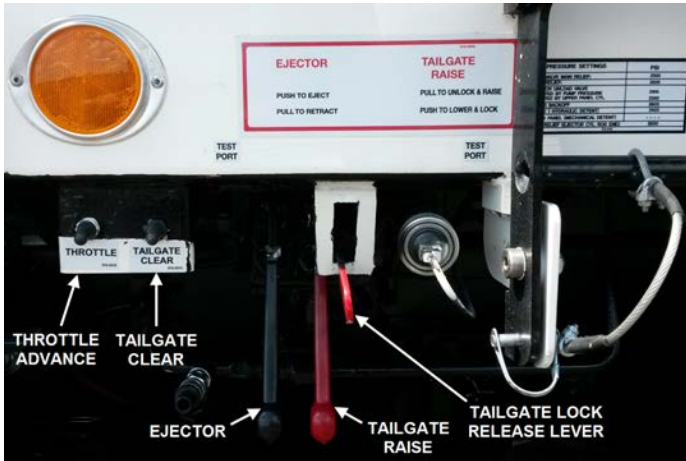

Figure 75. Tailgate Controls

### ⚠ CAUTION

Do not drive the unit for an extended distance. The unit may become unstable and you may cause damage to the tailgate cylinders.

### B. Ejecting Refuse

1. Extend the Ejector Panel
  - a. PRESS and HOLD the pump switch while you PULL the EJECT lever UP and HOLD until the ejector panel fully EXTENDS and comes to a complete stop.
  - b. The refuse is now unloaded from the unit.
  - c. RELEASE the EJECT lever and the THROTTLE ADVANCE switch.
2. Retract the Ejector Panel
  - a. Activate the pump activation switch until the ejector panel is fully RETRACTED and at the front of the body.
  - b. RELEASE the eject lever.

## UNLOADING REFUSE (CONTINUED)

### B. Ejecting Refuse (Continued)

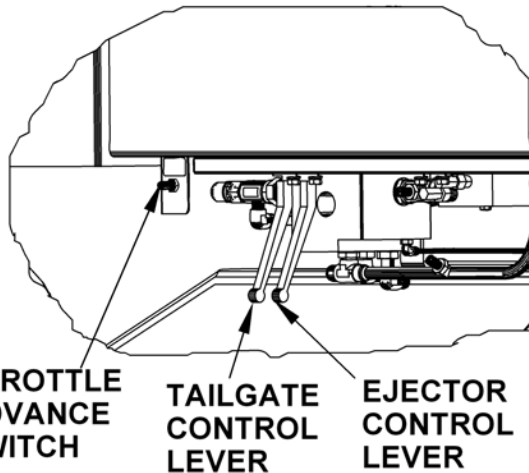
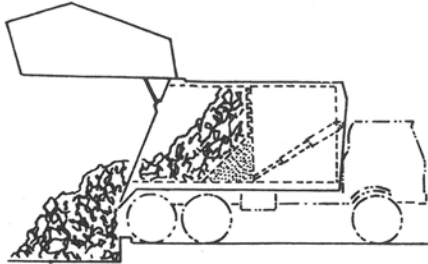

Figure 76. Unloading Refuse

### C. Clean and Inspect the Tailgate

#### **⚠ DANGER**

Always prop the tailgate when you leave it raised for maintenance, service or cleaning procedures. Any part of your body between the unit's body and the tailgate while you prop the tailgate or when the tailgate is propped is dangerous. Serious injury or death may occur if any part of your body is between the tailgate and the body if the tailgate suddenly closes.

- **BEFORE** you lower the tailgate, **MAKE SURE** the area where the tailgate seal mates with the body is **CLEAN AND FREE** of any refuse and debris.
- **DO NOT** drive the unit for an extended distance if you must move the vehicle to another area to clean and inspect the tailgate seal.
- **DO NOT** go under the tailgate to clear refuse, instead, use a broom or pole to clean the tailgate seal.
- Inspect the seal for possible wear or damage and replace if necessary.

## UNLOADING REFUSE (CONTINUED)

### D. Lowering the Tailgate

#### **⚠ DANGER**

A tailgate in motion is dangerous. Serious injury or death may occur if a person is struck by a moving tailgate or becomes trapped between the tailgate and the body. Clear the area near the tailgate of all unnecessary people before you lower the tailgate.

1. Activate throttle advance/pump switch to LOWER the tailgate.
2. HOLD the TAILGATE lever until the tailgate is COMPLETELY down and locked then RELEASE the switch.
3. Replace safety pins.

#### **NOTICE**

The TAILGATE OPEN warning light will go OFF and the alarm will stop when TAILGATE is FULLY locked.

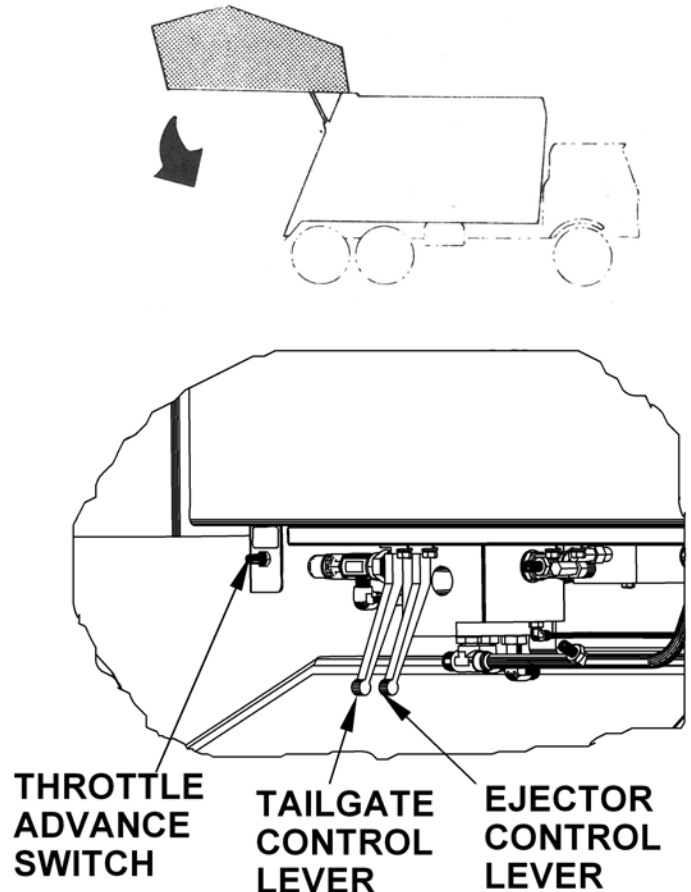

Figure 77. Lowering the Tailgate

## UNLOADING REFUSE (CONTINUED)

### E. Locking the Tailgate

1. HOLD the TAILGATE lever until the tailgate is COMPLETELY down and locked then RELEASE the switch.
2. Replace tailgate pins.

### F. Clean and Inspect the Hopper and Packer Panel

1. Put the unit in the Lock-Out/Tag-Out mode, turn the engine OFF and REMOVE the ignition keys.
2. Remove any remaining refuse in the hopper.
3. INSPECT the packer panel and hopper floor for excessive wear or possible damage. If there is excessive wear or other damage, get the damage repaired or parts replaced as soon as possible.
4. Take the unit out of Lock-Out/Tag-Out, then use the ignition keys and start the unit.
5. MOVE the packer on/off and work brake .
6. Use the blade and upper panel controls and do at least one cycle of the blade and upper panel: STARTING POSITION, OPEN and PACK. If the blade and upper panel do not operate correctly, report the problem to your supervisor for maintenance action.

### G. Remove Refuse from the Engine and Exhaust Areas

IMPORTANT! Inspect unit for refuse on or about the engine or exhaust components. Remove all refuse to prevent a fire.

### H. Sump Doors and Washout System

The DuraPack 5000 unit does not have sump doors.

If equipped, use the optional washout system to clean out the body and hopper at the end of a work day.

## UNLOADING REFUSE (CONTINUED)

### I. Preparing to Return to Route

See **Driving to Pick-up Locations**<sup>(119)</sup> and make sure the unit is properly set up for travel.

- The tailgate is fully LOWERED and CLOSED. Check the TAILGATE OPEN display indicator on the in-cab display. It must be GREEN (TG CLOSED).
- The tailgate clamps (turnbuckles) are tight and secure the tailgate.
- The left and right hand doors are both secured. For each door:
  - The quick release pin is secured in the barrel.
  - The wing screw is securely tightened against the door.
- For a unit with refuse, the sweep is up tight against refuse. For a unit with no refuse, the sweep is at the START POSITION.
- The System Enable button is OFF.
- You properly ADJUST and CLEAN the mirrors.
- All outside lights turn ON and OFF.
- If equipped, the side access door is CLOSED and LOCKED.

**SECTION 10**  
**END OF DAY PROCEDURES**

## PREVIEW

Read this section to learn about:

- Parking the Unit
- Final Inspection
- Report to Employer/Supervisor
- Ignition Keys

## END OF DAY PROCEDURES

### Parking the Unit

1. Park the unit in the space designated by your employer/supervisor.
2. Set the parking brake.

### Final Inspection

Perform a final inspection of the unit:

1. Clear the area of all people.
2. Start the engine if it is not running.
3. Make sure all lights and in-cab controls operate correctly.
4. Put the transmission in reverse while you press the service brake. The backup alarm should sound in the cab. If the alarm does not sound in the cab, report this to your employer/supervisor immediately.
5. Check the unit for fluid leaks from the hoses, cylinders, valves, pump and fittings. Report any leaks to your employer/supervisor.

6. Make sure all cylinders (except tailgate lock cylinders) are in their retracted position and make sure that the upper panel (slide) and sweep blade control levers are in the NEUTRAL position..
7. APPLY the parking brake.
8. Put the transmission in neutral and turn the engine OFF.
9. Put the unit in the **Lock-Out/Tag-Out mode** .
10. Open the air tank drain valve.
11. Turn the battery disconnect switch to OFF.
12. Follow the company policy for locking the cab doors.

### Reports to Employer/Supervisor

Complete any reports required by your employer/supervisor. If you found any problems during the final inspection, prepare the necessary report for the employer/supervisor.

### Ignition Keys

Put the ignition keys in a secure storage area designated by your employer/supervisor.

# DURAPACK 5000

NOTES:

**SECTION 11**  
**PREVENTIVE MAINTENANCE CHART**

# DURAPACK 5000

## BODY PREVENTIVE MAINTENANCE CHART

Preventive maintenance must be performed to ensure the safe and reliable operation of your unit. Use the chart below as a guideline for when essential items should be checked and serviced.

*HOURS OF OPERATION						
COMPONENT/SYSTEM	8	40	200	1000	2000	CHECK/SERVICE
Hydraulic System	☑					Check oil level – add if necessary
		☑				Check cylinders, pump, hoses, tubes, fittings, and adapters for leaks. Check hoses for cracks, crushes, and cover blisters. Repair or replace if necessary with genuine Heil parts. Any replacement hose should be the same size and pressure rating as listed on the original OEM hose.
		☑				Check Control valve seals for leaks. Repair or replace if necessary.
				☑		Replace filter after first 30 days of operation, then every 6 months or 1000 hours of operation OR when filter bypass light is ON.
				☑		Replace tank breather filter every time you replace filter element.
					☑	Drain, flush, and refill. Change filter element.
Electrical, Battery Cables	☑					Check for proper operation.
		☑				Check battery cables from battery to starter for loose cables, rubbing or damage and abrasions to cables. Replace if necessary.

# DURAPACK 5000

*HOURS OF OPERATION						
COMPONENT/SYSTEM	8	40	200	1000	2000	CHECK/SERVICE
Operator Controls	<input checked="" type="checkbox"/>					
Front Mount Pump or Power Take-Off (PTO)		<input checked="" type="checkbox"/>				Check seals for leaks and operation. Replace if necessary
		<input checked="" type="checkbox"/>				Check drive line for smooth operation. Replace as necessary.
		<input checked="" type="checkbox"/>				Check set screws for tightness. Tighten as necessary.
		<input checked="" type="checkbox"/>				Make sure keys are in place. Replace if necessary.
			<input checked="" type="checkbox"/>			For greaseable PTOs (non-wet spline), remove the pump's bolt flange about 2 inches from the PTO and apply grease to female pilot of PTO pump flange. Failure to lubricate female pilot of PTO as given may cause damage to the pump shaft. Greasing is NOT required on wet spline PTOs such as the Chelsea 890/897 series.
Grease Fittings		<input checked="" type="checkbox"/>				Lubricate as shown on Body Lube Chart.
Body Undercoating					<input checked="" type="checkbox"/>	Inspect body undercoating and repair as necessary.
Tailgate Seal Integrity	<input checked="" type="checkbox"/>					
Packer/Ejector Cylinder Preventive Maintenance	<input checked="" type="checkbox"/>	<input checked="" type="checkbox"/>	<input checked="" type="checkbox"/>			See <b>Packer/Ejector Cylinder Preventive Maintenance</b> in Service Manual.
* Daily = 8 hrs. Weekly = 40 hrs. Monthly = 200 hrs. 6 Months = 1000 hrs. Yearly = 2000 hrs.						

# DURAPACK 5000

NOTES:

**SECTION 12  
LUBRICATION GUIDE**

# DURAPACK 5000

## LUBRICATION GUIDE

Clean fittings before applying grease and always pump enough grease into joint to remove the old grease. Wipe off excess grease. Lubricate movable mechanical parts without fittings every 60 days with non-detergent engine oil.

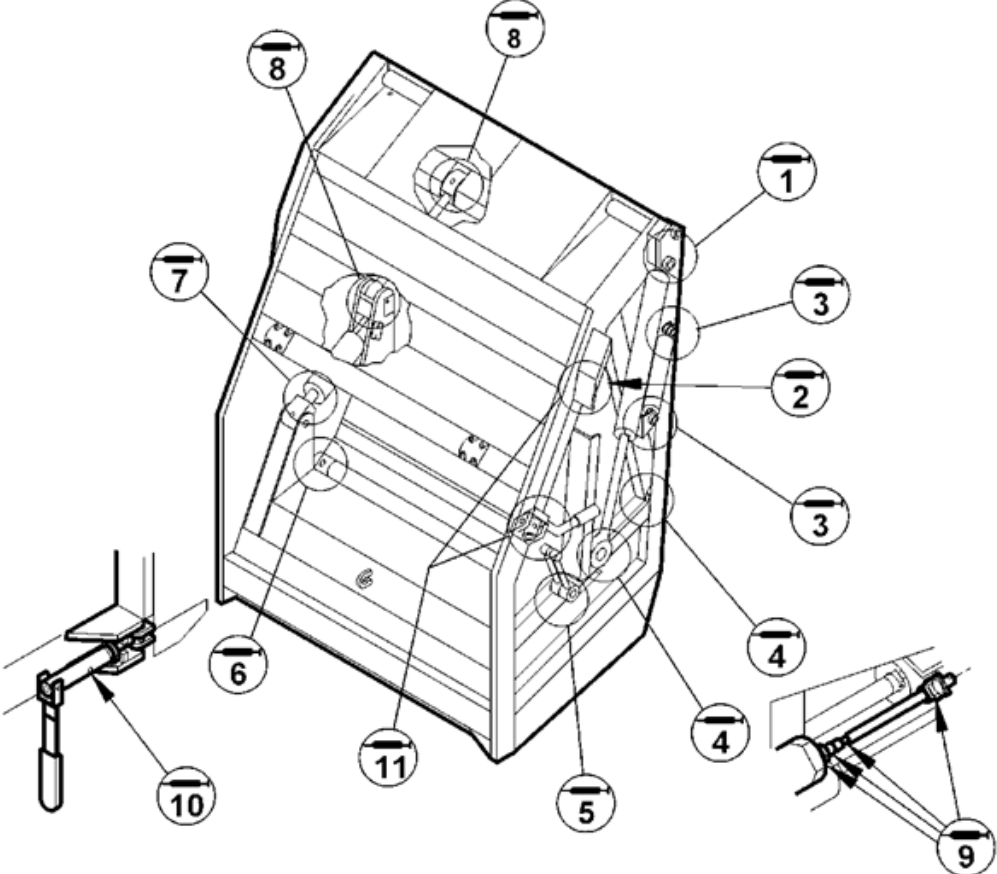

# DURAPACK 5000

## LUBRICATION GUIDE (CONTINUED)

REF. NO.	LOCATION	QTY.	INTERVAL
1	Tailgate Hinge	2	Weekly/40 Hours
2	Outside Packing Cylinder (Both Ends)	4	Weekly/40 Hours
3	Tailgate Raise Cylinder (Both Ends)	4	Weekly/40 Hours
4	Lower Link Pivot (Both Ends)	4	Weekly/40 Hours
5	Control Handles/Linkage:		Weekly/40 Hours
	A. Upper Bellcranks	2	
	B. Kick-Out Lever	1	
	C. Lower Yoke Assembly	2	
	D. Control Handle Pivots	2	
6	Packer Panel Pivot (Bottle Pin to Upper Panel)	4	Weekly/40 Hours
7	Inside Packing Cylinder (Both Ends)	4	Weekly/40 Hours
8	Upper Link Arms	4	Weekly/40 Hours
9	PTO (Pump) Drive Shaft	4	Weekly/40 Hours
	Front Mount Drive Shaft	3	Weekly/40 Hours
10	Tailgate Turnbuckle Clamps	2	Weekly/40 Hours
11	Container Mech. Control:		
	A. Handle	1	Weekly/40 Hours
	B. Upper Pivot	1	Weekly/40 Hours
12	Ejector Cylinder (Not Shown)	2	Weekly/40 Hours
13	Access Door Hinges (Not Shown)		Every 60 Days

# DURAPACK 5000

NOTES:

**SECTION 13  
COMPRESSED NATURAL GAS (CNG)  
OPTION**

## IMPORTANT SAFETY INFORMATION

### **WARNING**

THIS IS A COMPRESSED NATURAL GAS VEHICLE. CNG units are powered by compressed natural gas, which operates under significant pressures. Only those properly trained, certified, and qualified on CNG vehicle applications should perform service. All users must be aware of the risks associated with electric vehicles. IF YOU ARE NOT SURE IF YOU ARE QUALIFIED, CONSULT YOUR ORGANIZATION'S EHS FUNCTION BEFORE USE OR PERFORMING ANY WORK. Please note that various procedures are different from other Heil bodies due to the CNG system – please read this Manual and related documents in full. This Manual does not substitute for proper training and certification.

### **NOTICE**

A qualified person performing installation, repair, and maintenance work or system inspection on a CNG unit shall be properly trained in such functions. Where required, the training and licensing shall comply with local requirements.

Note: Local requirements can consist of provincial regulations or other requirements of the AHJ.



**Figure 78.**

## IMPORTANT SAFETY INFORMATION (CONTINUED)

### A. Safety Notices

Throughout this manual, safety notices are included to warn operators and maintenance technicians of the dangers associated with the described equipment operations and maintenance. Improper operation or maintenance procedures may cause serious injury or death. Safety notices accompany potentially hazardous situations throughout this manual. Please read and follow instructions carefully.

For supplemental information, refer to the following codes:

- United States: NFPA 52, State and Local Regulations, FMVSS 304
- Canada: CSA B109

---

### **DANGER**

The CNG Fuel System contains some lines that are under continuous high pressure. DO NOT attempt to loosen or disconnect those lines.

---

### **DANGER**

Natural Gas is Flammable and Explosive. Never use an open flame (match, lighter, or other) to light a work area near the CNG fuel storage system.

---

### **DANGER**

Keep work area well ventilated.

---

### **WARNING**

Do not start the engine if a natural gas leak is detected.

---

## IMPORTANT SAFETY INFORMATION (CONTINUED)

### **WARNING**

---

Never open system components while the system is under pressure. Treat all cylinders as full until defueling has been completed.

---

### **WARNING**

---

Never weld or perform any type of "hot work" on any part of a compressed natural gas vehicle unless the compressed natural gas fuel system has been purged with inert gas. This includes but is not limited to refraining from using sandblasters, unshielded power tools, grinders, or spark-producing hand tools without completely purging the natural gas fuel system in accordance with the instructions provided herein.

---

### **WARNING**

---

Avoid open flames and sparks near a compressed natural gas vehicle.

---

### **WARNING**

---

Do not smoke cigarettes, cigars, or use any other lit or sparking items within 30 feet of a compressed natural gas vehicle or a dispensing/filling station. Do not use a cell phone or other electronic device within 30 feet of a compressed natural gas vehicle or a dispensing/filling station.

---

### **WARNING**

---

When replacing CNG components, replace with equal or higher pressure rated components.

---

## PROPERTIES OF NATURAL GAS

CNG is a naturally occurring hydrocarbon gas mixture which consists primarily of methane. This gas is lighter than air, which means if gas were to leak, it would float upwards and quickly dissipate into the atmosphere.

CNG will burn only when in an air-to-gas mixture of approximately 5-15% so its range of flammability is limited compared to other fuels. The gas also has an ignition temperature of 1076°F which is significantly higher than diesel. As a fuel, CNG is less expensive and burns cleaner than diesel fuel, producing low emissions. These characteristics make CNG an efficient, safe choice for fueling vehicles.

It is:

- Colorless
- Non-corrosive
- Non-toxic

It has an:

- Auto Ignition Point: 900 - 1170° F (482 - 632°C)
- Lower Explosive Limit (%): 3.8 – 6.5
- Upper Explosive Limit (%): 13 – 17

## SIGNS OF A FUEL LEAK

An odorant which smells like rotten eggs is added to compressed natural gas to aid in detection of a leak. If you notice this kind of lingering odor coming from your vehicle, you may have a leak in the CNG fuel system.

NOTE: It is normal to detect this slight odor when the fueling nozzle is being connected or disconnected during the refueling process. The odor should quickly dissipate when fueling has been completed.

If you notice any of the following, you may have a leak in the CNG fuel system:

- Frosting at suspected leak point
- Bubbling in wet area
- Blowing or hissing sound
- Flames, if a leak has ignited

If a fuel leak is suspected, the system should be shut down immediately. Refer to **Fuel System Shut Down Procedure** <sup>176</sup>. Have the unit inspected for leaks by a qualified service technician using a methane detector or an approved liquid leak detector. Do not use any other method or products to find leaks.

## CNG FUEL SYSTEM COMPONENTS

The following pages detail a typical CNG system configuration. Your CNG fuel system configuration may vary.

### A. Fuel Management Module (FMM) Functions

The CNG Fuel Management Module serves multiple functions within a natural gas vehicle (NGV) fuel system. These functions include:

- Storage tank refueling
- Transfer fueling (defueling)
- Pressure display of high pressure side of system
- Pressure display of low pressure side of system
- Manual and ignition controlled fuel shut-off
- Pressure reduction from storage tanks to engine supply
- Fuel system filtration
- Liquid removal from fuel system

### B. Fuel Management Module (FMM) Components

#### 1. Manual Shut-Off Valve

The FMM Manual Shut-Off Valve isolates the fuel storage system from the engine. The manual shut-off valve handle is RED and is located on the left front of the fuel control module. Rotate the handle clockwise so arrow points right to the 'OFF' position to prohibit fuel flow from the tanks to the vehicle's engine.

Rotate the handle counterclockwise so arrow points up to the 'ON' position to allow fuel flow from the tanks to the vehicle's engine.

#### 2. High Pressure Gauge

Refer to the manufacturer's manual for information.

#### 3. Low Pressure Gauge

Refer to the manufacturer's manual for information.

#### 4. Fill Receptacles

Fill receptacles are used to fill the CNG storage cylinders with fuel. There are two sizes: standard NGV1 (slow) or HD bus transit (fast) fill. The receptacles are equipped with built-in check valves to prevent fuel from escaping when the fuel fill nozzle is connected and disconnected.

## CNG FUEL SYSTEM COMPONENTS (CONTINUED)

### **WARNING**

Fill receptacles shall only be replaced with receptacles that are equal pressure rating.

### **WARNING**

Prevent hoists or jacks from coming into direct contact with containers.

## B. Fuel Management Module Components (Continued)

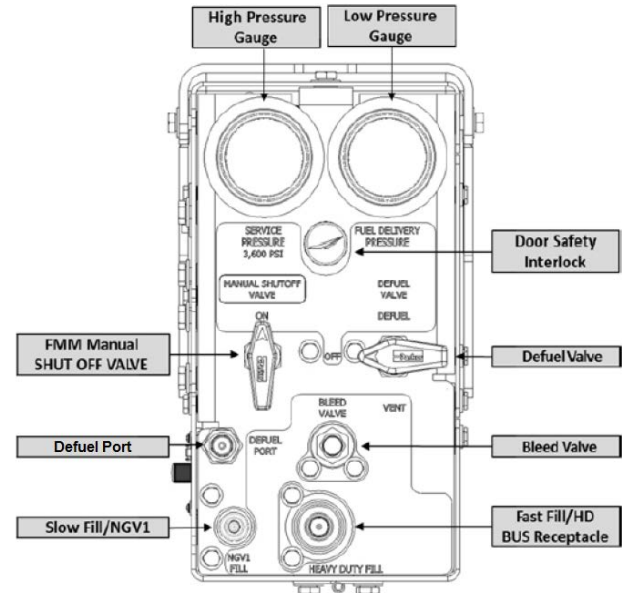

**Figure 79. Manual Shut-Off Valve (Typical arrangement; models may vary slightly in component positioning.)**

# DURAPACK 5000

## CNG FUEL SYSTEM COMPONENTS (CONTINUED)

### **WARNING**

Prohibit personnel from walking on containers unless permitted by the container manufacturer.

### C. CNG Fuel System Components

#### 1. Fuel Cylinder(s)

The fuel cylinder(s) stores CNG fuel at a service pressure of 3,600 psi. The fuel cylinders used on CNrG Tailgate vehicles are type-4 composite containers, manufactured to meet FMVSS 304 and NGV2-2019 specifications. The fuel cylinders used on Top of Body and Back of Cab CNG vehicles with the Agility FMM varies, as those are supplied by the customer. In accordance with applicable regulations, the cylinders must display permanent labels which provide information necessary for inspection.

#### 2. Cylinder Manual Shut-Off Valve

The cylinder Manual Shut-Off Valve attached to each cylinder controls the flow of gas in and out of the cylinder. Each valve is located under a valve access cover labeled "MANUAL SHUTOFF VALVE" that is adjacent to the cylinder. Turn the valve handle FULLY clockwise to close the valve or FULLY counter-clockwise to open it.

#### 3. Check Valve

The 1-way check valve, located in the FMM box, is used to prevent fuel from backing up during the fuel filling process.

#### 4. High Pressure Filter

This filter is in the FMM box. Refer to the manufacturer's manual for information.

#### 5. Pressure Regulator

Refer to the manufacturer's manual for information.

#### 6. Solenoid Valve

Refer to the manufacturer's manual for information.

#### 7. Pressure Relief Devices

The Pressure Relief Devices (PRD) are thermally-activated valves that open at a temperature of approximately 230°F. In the event of a fire, they are designed to release the fuel stored in the cylinders a safe distance from the vehicle to prevent over-pressurizing the fuel cylinders. When activated, the PRD cannot be closed and will vent all gas.

## CNG FUEL SYSTEM COMPONENTS (CONTINUED)

### **WARNING**

The Bleed Valve shall not be used to defuel the system. The system must be defueled before using the bleed valve. See **Transfer Fueling (Defueling) section.**  187

### C.CNG Fuel System Components (Continued)

#### 8. High Pressure Lines

These are stainless steel lines carrying high pressure CNG gas in them. They are routed between FMM box and CNG tanks located on the truck to connect various CNG components to each other as needed to function correctly. They are also located from any of the auxiliary fill locations you may have as an option on your truck going to FMM box. These lines are high pressure lines that can be isolated from the CNG tanks by closing the shutoff valve on individual tanks for service.

#### 9. High Pressure Live Lines

These are stainless steel lines carrying high pressure CNG gas in them. They are routed between CNG tank valve port to the PRD (pressure relief device) for each tank. These lines are high pressure lines that CANNOT be isolated from the CNG tanks by closing the shutoff valve on individual tanks for service and the tank has to be completely defueled and purged before any maintenance work is done on these lines.

#### 10. Vent Lines

These are stainless steel lines connecting the outlet of PRD (pressure relief device) port and venting the gas to atmosphere at top of the vehicle when the PRD activates. In normal operation, they do not carry any pressure in them and are isolated from the high pressure system as long as the PRD does not activate or is not uninstalled.

### **WARNING**

1. Only qualified personnel shall be permitted to service pressure relief devices.
2. No pressure relief valve that has been in service shall be repaired or reworked without the written authorization of the pressure relief device manufacturer, valve manufacturer, fuel container manufacturer, or vehicle manufacturer. Any device that has been activated shall not be reworked or reused and shall be removed from service.
3. No pressure relief device that has been in service shall be reinstalled on another fuel cylinder.

### **NOTES:**

## FUEL SYSTEM SHUT DOWN PROCEDURE

1. Turn OFF the Fuel Management Module (FMM) Manual Shut-Off Valve.
2. Turn OFF the Fuel Cylinder Manual Shut-Off Valve on EACH tank.

## CNG VEHICLE OPERATOR EMERGENCY RESPONSE

### **WARNING**

During an emergency situation, never jeopardize safety to shut down the system. If it becomes evident that the steps cannot be safely completed, move to a safe distance, call 9-1-1 and alert emergency personnel of the situation, informing them of the presence of a CNG system and that it is not properly shut down.

### Emergency Response for Gas Leaks

If the vehicle has sustained damage or a gas leak is detected:

1. Do not approach the vehicle if any sources of ignition may exist such as fire, sparks, electrostatic charges, lights or electronic devices.
2. If the vehicle is indoors, move the vehicle outside and away from any ignition sources.

3. Do not use road flares.
4. Do not smoke or allow anyone else to smoke near the vehicle.
5. Turn OFF the ignition switch, set the parking brake and turn OFF the battery at the main disconnect.
6. If it is safe to do so, turn OFF the Fuel Management Module Manual Shut-Off Valve and turn OFF the Fuel Cylinder Manual Shut-Off Valve on EACH tank. Check the fuel system near the damaged area for leaks by smell, sight, and sound. CNG is odorized and can be detected by smell.
7. Keep traffic and pedestrians away.
8. Beware that gas may continue to leak once ignition is turned off and the manual shutoff valves are closed.
9. Have a qualified technician verify leak locations with suitable methane detection fluid.
10. Have the leaks repaired by a qualified technician immediately.

### Vehicle Fire Procedures

In the event of a CNG fire, it is imperative that the vehicle operator acts quickly:

1. Get passengers out of the vehicle as quickly as possible.
2. Evacuate the area.
3. Call 9-1-1.
4. If possible without putting yourself in harm's way, dump the refuse load from the body and move the vehicle a safe distance away from any burning refuse.

## CNG VEHICLE OPERATOR EMERGENCY RESPONSE (CONTINUED)

### CNG Vehicle Emergency Shut Down Procedure

#### **WARNING**

During an emergency situation, never jeopardize safety to shut down the system. If it becomes evident that the steps cannot be safely completed, move to a safe distance, call 9-1-1 and alert emergency personnel of the situation, informing them of the presence of a CNG system and that it is not properly shut down.

#### **NOTICE**

Defueling shall be performed only by a qualified person using written procedures.

Complete the following steps to shut down the CNG system:

1. Turn OFF Ignition and Electrical System.
2. Turn OFF Fuel Management Module Manual Shut-Off Valve.
3. Turn OFF the Fuel Cylinder Manual Shut-Off Valve on EACH tank.
4. Call Technical Services at 866-310-4345 for further assistance.

### Emergency Venting/Defueling Procedure

If an emergency arises in which the fuel must be purged immediately, an emergency vent can be performed as follows:

1. Ensure that an electrical ground connection has been established between the cylinders, the vent system, and earth ground.
2. Connect the on-board defueling connection to the vent system using a conductive high pressure defueling hose.
3. Slowly open the hand valve to achieve a slow and steady flow to prevent freezing. No gas flow may indicate a normally closed solenoid valve on the cylinder. Consult the vehicle manufacturer for information on opening electronic solenoids.
4. Allow the on-board storage system to vent completely.
5. When completed, disconnect the on-board defueling connection from the vent system and disconnect the earth ground.

## STARTING VEHICLE

### NOTICE

Starting a natural gas vehicle requires a delay between the battery power being turned on and the starter motor being activated.

1. Make sure that the system has been properly leak tested and that no leaks exist.
2. Make sure that plastic caps are installed on all exposed vent lines. For tailgate mounted CNG, vent lines route to the top of the tailgate. If the plastic caps are missing, contact Heil Parts Central for replacement caps at 800-528-5308.
3. Make sure that the cylinder shut-off valves (one on each cylinder) are “OPEN” and the manual shut-off valve is “ON”.
4. Make sure that the FMM door is closed and all the remote fill locations (if present on truck) dust cap on receptacle are closed. If open, the truck will not crank.
5. Without starting the engine, turn the key to the “RUN” position and wait 20-30 seconds. This will allow the fuel to properly fill the system and provide adequate back-pressure for the high-pressure solenoid valve to function properly.
6. Start the engine.
7. If this is the first start of the day, let the vehicle idle for five minutes. This will allow coolant to warm the fuel and ensure that the low-pressure lines down-stream of the primary pressure regulator do not freeze up. On extremely cold days, the vehicle may have to idle for a longer period until the fuel warms adequately.

## FUELING PROCEDURE

### NOTICE

MUST confirm that the unit is being filled from a CNG source.

### A. CNG Fueling Steps

Two options exist for filling a vehicle with CNG – timed fill or fast fill. Despite the size of the receptacle, the fueling hose connects in the same manner for either type of fill.

### WARNING

BEFORE fueling the CNrG Solenoid System (if equipped), **Fuel Fill Mode** MUST be engaged on the in-cab InSight Diagnostic Display. **While Fuel Fill Mode is engaged, the system will not detect leaks.**

The steps include:

1. Locate the fueling fill receptacle in the CNG fuel module. Optional fill receptacles may be installed in a remote location on the vehicle's front bumper.
2. Remove the dust cover on the fill receptacle.
3. Remove fueling nozzle from the CNG dispenser holder.

## FUELING PROCEDURE (CONTINUED)

5. Begin fueling the CNG vehicle.
6. When complete, disengage the Fueling Nozzle.
7. Return the nozzle to the CNG dispenser.
8. Replace the dust cover on the receptacle.
9. Close the CNG fuel module door and engage door lock.

### B. Types of Fueling Nozzles

Depending on the fueling station, different types of fueling nozzles may be utilized. Refer to the figures below and on the next page to determine which type of fueling hoses you will be using.

#### 1. Type 1:

When utilizing this type of nozzle, follow directions below to refuel:

- a. Slide the nozzle over the receptacle intake. In order to properly engage the fill hose with the receptacle, hold the nozzle in one hand. With the free hand, twist the lever counterclockwise to line up the two arrows, facing each other. Complete the connection by pushing the fueling hose fully onto the receptacle.
- b. Once the nozzle fits completely onto the fill receptacle, you will hear a click and the arrow on the lever will shift, misaligning with the arrow on the actual nozzle. This indicates that the nozzle fueling nozzle is properly seated onto the receptacle.

- a. When the nozzle fully connects, turn the lever clockwise until both arrows are pointing toward the fill receptacle to begin fueling.
- b. When fueling is complete, release the nozzle connection. Holding the nozzle in one hand, use the other hand to turn the nozzle so that arrows again point toward each other (as shown in step "a"). You will hear a release of pressure.
- e. Disconnect the fuel hose, and return it to the fuel dispenser.



**Figure 80. Type 1 Fueling Nozzle**

## FUELING PROCEDURE (CONTINUED)

### B. Types of Fueling Nozzles (Continued)

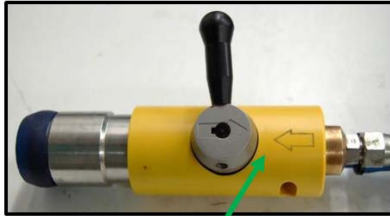

\*\*\*NOTE: Arrows must be aligned as shown to allow proper engagement of the hose with the fill receptacle.

**Figure 81. Type 1 Fueling Nozzle**

#### 1. Type 1 (Continued):



Arrows must be aligned and pointing toward the fill receptacle to allow fueling.

**Figure 82. Type 1 Fueling Nozzle**

#### 2. Type 2:

This fueling nozzle operates in the following manner:

- a. Locate fill receptacle and remove dust cap.
- b. Slide fueling hose nozzle onto the fueling receptacle.
- c. Compress the hand grip until the locking lever engages.
- d. Begin fueling.
- e. When complete, release the locking lever and disconnect the fueling hose.



**Figure 83. Type 2 Fueling Nozzle**

## FUELING PROCEDURE (CONTINUED)

### 3. Type 3:

To utilize this nozzle:

- a. Locate fill receptacle and remove dust cap.
- b. Holding firmly, press nozzle onto fill receptacle.
- c. Rotate lever clockwise 180° to begin fueling.
- d. When fueling is complete, rotate lever counterclockwise 180° to allow fuel hose disconnection.



**Figure 84. Type 3 Fueling Hose**

## NOTES:

## CNG FUEL SYSTEM MAINTENANCE

Routine maintenance of the compressed natural gas system in accordance with the **CNG Fuel System Inspections Section** <sup>1881</sup> will ensure that the system and components are functioning properly. Refer to your Heil Service Manual for CNG fuel system schematics.

### **WARNING**

1. Only qualified personnel shall be permitted to service relief devices.
2. No pressure relief valve that has been in service shall be repaired or reworked without the written authorization of the pressure relief device manufacturer, valve manufacturer, fuel container manufacturer, or vehicle manufacturer. any device that has been activated shall not be reworked or reused and shall be removed from service.
3. No pressure relief device that has been in service shall be reinstalled on another fuel cylinder.

### **WARNING**

A qualified performing installation, repair, and maintenance work or system inspection shall be properly trained in such functions. Where required, the training and licensing shall comply with local requirements.

NOTE: Local requirements can consist of provincial regulations or other requirements of AHJ.

### **WARNING**

Reinstall containers to their original configuration using approved gaskets, bolts, nuts, washers, and parts in accordance with the recommendations of the vehicle or container manufacturer or system installer.

### **WARNING**

System components must not be under pressure during servicing. Servicing components under pressure may cause serious injury.

# DURAPACK 5000

## MAINTENANCE PART NUMBERS

When replacing CNG components, replace with equal or higher pressure rated components.

Customers should replace the FMM with the version/Part Number that is currently on their truck.

PART NUMBER	DESCRIPTION
151-4784	Standard Fuel Management Module

PART NUMBER	DESCRIPTION
151-4785	Smart Fuel Management Module

Note: For a complete breakdown of the FMM and CNG system, refer to the Parts Central Electronic Parts Catalog (EPC).

Register online to gain access to the EPC:  
<https://epc.partscentral.com>

Google Chrome web browser is recommended.

## NOTES:

# DURAPACK 5000

## DEPRESSURIZING PROCEDURE FOR HEIL TRADITIONAL CNG TAILGATE SYSTEM

It is necessary to prepare the truck to be serviced. A mechanic's initial focus while preparing the vehicle for service should be **safety**. The primary preparation involves relieving the pressure within the system BEFORE performing any maintenance procedures on the truck that does not involve working on or near CNG fuel system or its components. Use the following procedure to remove fuel pressure from the lines connected to the high-pressure filter assembly.

### WARNING

After following the Depressurization Procedure, pressure will still remain inside the fuel cylinder(s). Use care when loosening fittings for the first time. DO NOT open any cylinder Manual Shut-Off Valves after any CNG fitting, connection, or component is loosened or disassembled

### WARNING

Never weld on any fuel system components without completely defueling the components. Protect fuel system components from heat damage by either removing or covering the components with a welding blanket or other approved shielding when working near CNG fuel system or its components. Check for the presence of gas leaks before welding. Welding can ignite the fuel, resulting in an explosion or fire causing serious personal injury or death.

## DEPRESSURIZING PROCEDURE FOR HEIL TRADITIONAL CNG TAILGATE SYSTEM (CONTINUED)

1. Make sure that the vehicle ignition is turned OFF, vehicle parked on level ground, parking brake on, wheels chocked on one axle or more.
2. Close ALL cylinder Manual Shut-Off Valves (one on each cylinder) by turning the valve clockwise to the OFF position. See the image below.

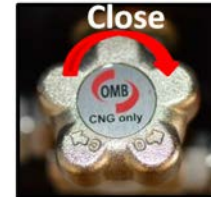

**Figure 85.**  
Cylinder Manual  
Shut-Off Valve



**Figure 86.**  
Manual Shut  
Off Valve

### WARNING

Pressure still remains inside the fuel cylinder(s). Use care when loosening fittings for the first time. Do NOT open the fuel cylinder valves or loosen any fitting / PRD installed in any of the cylinder(s) valve live ports.

## HIGH PRESSURE FILTER DRAIN PROCEDURE

1. Remove the excess fuel in the filter per the **Depressurizing Procedure** <sup>184</sup>.
2. Make sure the FMM Manual Shut-Off Valve is in the OFF position.
3. Locate and access the high pressure coalescing filter inside the filter service access door. The filter location will vary, depending on the system configuration.
4. Locate the drain plug at the bottom of the filter. Hold a cloth under the port to catch any draining liquid.
5. Remove the plug and allow the liquid inside the filter to drain.
6. Re-install the drain plug and torque to 27 FT-LBS.
7. Follow the Re-pressurizing procedure in this manual for the system applicable on your truck.

## HIGH PRESSURE FILTER CHANGE PROCEDURE

1. Remove the excess fuel in the filter per the depressurization procedure.
2. Ensure the FMM Manual Shut-Off Valve is in the OFF position.
3. Locate and access the high pressure coalescing filter inside the service access door/panel. The filter location will vary, depending on the system configuration.
4. Unscrew and remove the filter bowl from the filter housing. Note the filter is equipped with wrench flats to assist removal.
5. Empty and clean the filter bowl.
6. Remove the filter element by grasping and pulling it downward out of the filter housing. Place the new filter element into position and press it into place.
7. Install a new o-ring (supplied with the filter element) into the groove on the filter housing, using lubricant supplied in the kit.
8. Re-install the filter bowl in the filter housing and torque to 40 FT-LBS.
9. Follow the Re-pressurizing procedure in this manual for the system applicable on your truck.

## WELDING AND HOT WORK PROCEDURES

### **WARNING**

Never weld or perform any hot work that may introduce or produce sparks on a compressed natural gas vehicle unless the compressed natural gas fuel system has been purged with inert gas.

### **DANGER**

Never weld on any fuel system components. Welding can ignite the fuel, resulting in an explosion or fire causing serious personal injury or death.

If any welding or 'hot work' (i.e., any work that involves burning or use of tools that produce a spark, flame, or source of ignition) is required on a CNG fuel vehicle excluding the CNG fuel system, you must perform the following procedures:

1. Conduct work in a well-ventilated area.
2. Perform defueling procedure as instructed in this manual.

## WELDING AND HOT WORK PROCEDURES (CONTINUED)

3. Purge the CNG fuel system with inert gas, including the tanks. See **Purging with an Inert Gas Prior to Welding or Major Repairs**.
4. Use a welding blanket to protect the fuel system from slag and sparks produced from welding and hot work operations.
5. Once the work is finished, refuel the system and make sure it's running as expected.

## LIFTING THE VEHICLE

### **WARNING**

Never use any part of the fuel system as a lifting point to raise the vehicle. Do not allow fuel system components to come into contact with any part of the lifting device. The fuel system can become damaged, resulting in a leak. Serious personal injury or death can occur if the gas is ignited.

Always raise the vehicle using the lifting points recommended by the vehicle manufacturer. Refer to the vehicle manufacturer's instructions for correct lifting instructions.

## TOWING THE VEHICLE

### **WARNING**

Do not attach towing equipment to or allow towing equipment to come into contact with any part of the fuel system. The fuel system can become damaged, resulting in a leak. Serious personal injury or death can occur if the gas is ignited.

Before towing the vehicle, close the Manual Shut-Off Valves on the FMM and all fuel cylinders using the **Fuel System Shut Down Procedure** <sup>176</sup>.

Once the fuel system is shut down, follow the vehicle manufacturer's instructions for towing the vehicle.

## NOTES:

## PRE-TRIP INSPECTION

Perform a Pre-Trip Inspection each day before driving the vehicle.

1. Verify the Manual Shut-Off Valve on the FMM is in the ON position.
2. Check the high-pressure gauge on the FMM to ensure it is operating and reading in a range consistent with the fuel gauge on the dash board. The fuel system maximum pressure is 3,600 psi.

NOTE: Pressure of less than 250 psi could make the engine run rough.

3. Check the vent ports and vent caps for any signs the PRDs have been activated. Verify the vent ports and vent caps are clear of debris or damage.
4. Check the entire fuel system for any signs of damage or wear. Include checks for:
  - a. Gas leaks – Smell for gas, look for frost or ice, and listen for hissing noises at joints and components.
  - b. Look for external damage to housings and covers.
5. Drain the low pressure filters per the engine manufacturer's recommendation.
6. Turn the ignition key to ON and check that the low pressure gauge reading is approximately 85-150 psi.
7. Verify the dashboard fuel gauge is functioning properly.

8. Have the fuel system and cylinders inspected by a certified CSA Cylinder and Fuel System Inspector if damage is found on any part of the components or structural parts of the fuel system.

## WEEKLY SYSTEM INSPECTION

Perform the Weekly System Inspection to ensure the system is operating correctly, safely, and to maximize component performance.

1. Verify all of the cylinder Manual Shut-Off Valves move freely and are in the ON position.
2. Visually inspect the fuel system for any signs of damage or wear.
3. Check for damage on the cylinder shields and covers.
4. Check to ensure the cylinders are mounted securely. Inspect the mounts, brackets, rubber isolators, and all fasteners.
5. Check for leaks on all CNG fuel plumbing tubes, hoses, and fuel flow components. Check for the odor of rotten eggs. Look for frosting or the sound of hissing at valves and fittings.
6. If any system components or structural parts are damaged, the system and cylinders must be inspected by a certified fuel system inspector.

# DURAPACK 5000

## CNG FUEL SYSTEM INSPECTION/PREVENTIVE CARE SCHEDULE

ITEM	FREQUENCY
Check Vent Lines	Daily
Drain Low Pressure Filter	Daily
Perform <b>Daily CNG Fuel System Inspection</b>  on next page.	Daily
Replace Low Pressure Filter	Refer to the engine manufacturer for maintenance and replacement guidelines.
Drain High Pressure Filter	Weekly
Replace High Pressure Filter Element	At regular oil change intervals or every 30,000 miles
Drain Vent Lines	Every month (or immediately if vent cap is missing. MUST replace with new vent cap)
Leak Test with Methane Detector	Monthly, or if involved in any accident, or if you smell gas.
Component Inspection	Monthly
Cylinders	Inspect compressed gas cylinders as outlined by cylinder manufacturer
NOTE: All inspections to be completed by a qualified and trained person.	

## CNG FUEL CYLINDER AND SYSTEM INSPECTION

### **WARNING**

If a CNG-fueled vehicle has been involved in an accident or fire, the system and cylinders must be inspected by a certified CNG fuel system inspector. The system shall be repaired and retested before being returned to service.

### **NOTICE**

Inspections must be performed by qualified inspectors using guidelines from the fuel cylinder manufacturer in addition to the guidelines listed here.

1. Based on cylinder manufacturer recommendations, FMVSS 304, and industry standard practices, visual CNG cylinder inspections should be performed every 12 months by a qualified inspector.
2. In addition, Heil recommends a daily walk-around or pre-trip and post-trip visual inspection be performed.
3. The qualified person performing the repair and retesting shall prepare a document certifying that the CNG fuel system is acceptable for return to service and present the document to be retained by the vehicle's owner/operator and a copy to be retained by the qualified person. By license number or vehicle identification number, the document shall identify the vehicle CNG fuel system parts worked on, describe the work done and dates of work, and provide the qualified person's name and contact information.

## DAILY CNG FUEL SYSTEM INSPECTION

Inspect the following items each day before vehicle operation:

1. Make sure all manual tank valves and the red-handled emergency shutoff valve on the FMM are in the OPEN position.
2. Check the high pressure gauge to make sure enough fuel is on-board and refuel if necessary.
3. Drain the low pressure filters located at engine per the engine manufacturers' recommendation.
4. Turn the ignition key to the on position, and watch the low pressure gauge. It should show between 85-140 psi.
5. Check the dashboard fuel gauge to make sure it is functioning.
6. Check the entire fuel system for any signs of damage or wear. Include checks for:
  - a. Gas leaks – Smell for gas, look for frost or ice and listen for hissing noises at joints and components.
  - b. Pressure Relief Device (PRD) components – Make sure all PRD vent line caps are in place.
  - c. Structural damage – Housings, covers bent or damaged, fasteners missing or loose, check inside of tailgate for dents over 1/4" deep, or punctures.
7. Check the FMM door sensor interlock by opening the door and trying to start the vehicle. The vehicle should not start.

## CNG FUEL SYSTEM TROUBLESHOOTING

Heil offers support via the technical assistance line to assist with troubleshooting.

Please provide the following when calling Heil Technical Services at 866-310-4345 with troubleshooting questions:

1. Serial # of CNG Fuel Module
2. Truck Serial #
3. Details of:
  - When the problem started
  - What the problem entails
  - Any troubleshooting performed
  - Results of troubleshooting actions

# DURAPACK 5000

## CNG FUEL SYSTEM TROUBLESHOOTING (CONTINUED)

The following table lists possible problems, along with causes, corrections, and results.

PROBLEM OBSERVED	POSSIBLE CAUSES	CORRECTIVE/ DIAGNOSTIC ACTIONS	RESULTS AND OTHER ACTIONS
Vehicle's starter will not operate.	Interrupt door switch signal is not being properly recognized by the vehicle.	Disconnect the 12-pin electrical connector at the rear of the fuel module. Use an ohm meter or continuity tester across pins 9 (GRN) and 10 (YEL) of the fuel module side of the connector (female connector). Press and release the fuel module interrupt door switch. When the switch is depressed, there should be continuity between pins 9 (GRN) and 10 (YEL). Continuity should be lost when the switch is released.	If operation of the door switch makes and breaks continuity as described, and the starter will not operate, there is most likely a problem in the vehicle's wiring.  If the operation of the door switch does NOT make or break continuity as described, there is most likely a wiring problem in the fuel module.  If the problem cannot be resolved, call <b>866-310-4345</b> for technical assistance.

# DURAPACK 5000

## CNG FUEL SYSTEM TROUBLESHOOTING (CONTINUED)

The following table lists possible problems, along with causes, corrections, and results.

PROBLEM OBSERVED	POSSIBLE CAUSES	CORRECTIVE/DIAGNOSTIC ACTIONS	RESULTS AND OTHER ACTIONS
<p>Vehicle's starter operates but the vehicle does not run.</p>	<p>Fuel is not making it through the fuel module to the engine.</p>	<p>*The manual valve on the front of the fuel module should be set to "On".</p> <p>*The fuel module high pressure gauge should read above 5000 psi. Disconnect the 12-pin electrical connector at the rear of the fuel module. Use a DC voltmeter across pins 8 (BLU) and 9 (GRN) of the vehicle side of the connector (male connector). The voltage should read:</p> <ul style="list-style-type: none"> <li>• Ignition switch "Off" 0 vdc.</li> <li>• Ignition switch "Run" 12 vdc.</li> <li>• Ignition switch "Start" 12 vdc.</li> </ul> <p>*Reconnect the 12-pin electrical connector at the rear of the fuel module. Have an assistant repeatedly cycle the ignition switch between "Off" and "Run" while listening for the "click" of the fuel solenoid being actuated near the maintenance door.</p>	<p>*If the voltage does NOT change as described, the problem is most likely located in the vehicle's electrical signal that actuates the fuel solenoid.</p> <p>*If the voltage changes as described and the "click" of the fuel solenoid is detected, the problem is most likely an engine control problem prohibiting the vehicle from starting.</p> <p>*If the voltage changes as described but the "click" of the fuel solenoid is NOT detected then the problem is most likely a failed solenoid in the fuel module.</p> <p>*If the problem cannot be resolved, call <b>866-310-4345</b> for technical assistance.</p>

## CNG FUEL SYSTEM TROUBLESHOOTING (CONTINUED)

The following table lists possible problems, along with causes, corrections, and results.

PROBLEM OBSERVED	POSSIBLE CAUSES	CORRECTIVE/DIAGNOSTIC ACTIONS	RESULTS AND OTHER ACTIONS
<p><b>Heil Standard CNG and CNrG Tailgate Solenoid System Options:</b> In-cab fuel gauge does not indicate the fuel level correctly.</p>	<p>The fuel module pressure transducer, the fuel gauge or the interconnecting wiring may be defective.</p>	<p>Confirm that the 12-pin electrical connector at the rear of the fuel module is connected and place the vehicle's ignition switch in the "Run" position. Use a voltmeter to read:</p> <ul style="list-style-type: none"> <li>• Voltage between connector positions 2 (RED) and 3 (BLK). the voltage should be 12 vdc.</li> <li>• Voltage between connector positions 3 (BLK) and 4 (WHT). the voltage should be between 0.5 to 5.0 vdc.</li> </ul>	<p>*If the voltage across 2 and 3 is 0 or significantly below battery voltage, there is a problem with the vehicle's wiring not supplying power to the fuel module's pressure transducer.</p> <p>*If the voltage across 3 and 4 is either 0 or 5.5 vdc, the fuel module's pressure transducer is most likely defective. Call <b>866-310-4345</b> for technical assistance.</p> <p>*If the voltage across 3 and 4 is between 0.5 to 5.0 vdc then the fuel module's pressure transducer is operating correctly. The problem is likely in the vehicle's wiring or the in-cab fuel gauge.</p> <p>*If the problem cannot be resolved, call <b>866-310-4345</b> for assistance.</p>

## CNG FUEL SYSTEM TROUBLESHOOTING (CONTINUED)

The following table lists possible problems, along with causes, corrections, and results.

PROBLEM OBSERVED	POSSIBLE CAUSES	CORRECTIVE/DIAGNOSTIC ACTIONS	RESULTS AND OTHER ACTIONS
<p><b>Heil CNrG Tailgate Solenoid System Option:</b> In-cab Display does not indicate the fuel level correctly or an alarm is activated on the Display indicating "Transducer-# Unplugged/Short Check Sensor and Wiring" Fail for a given Tank#.</p>	<p>The fuel cylinder pressure transducer or the interconnecting wiring may be defective.</p>	<p>Confirm that the 3pin electrical connector at the transducer is connected and place the vehicle's ignition switch in the "Run" position. Use a voltmeter to read:</p> <ul style="list-style-type: none"> <li>• Voltage between connector positions A (BRN) and B (BLK). The voltage should be approximately 12 vdc.</li> <li>• Voltage between connector positions B (BLK) and C (YEL). The voltage should be between 0.5 to 5.0 vdc.</li> </ul>	<p>*If the voltage across A and B is 0 or significantly below battery voltage, there is a problem with the vehicle's wiring not supplying power to the fuel module's pressure transducer.</p> <p>*If the voltage across B and C is either 0 or 5.5 vdc, the fuel tank's pressure transducer is most likely defective. Call <b>866-310-4345</b> for technical assistance.</p> <p>*If the voltage across B and C is between 0.5 to 5.0 vdc then the fuel module's pressure transducer is operating correctly. The problem is likely in the Display or the Controller.</p> <p>*If the problem cannot be resolved, call <b>866-310-4345</b> for assistance.</p>

# DURAPACK 5000

## HEIL CNrG SENTINEL SOLENOID SYSTEM OPTION

When equipped, the optional Heil CNrG Solenoid System will monitor and display live in-cab CNG system and tank pressures and notifications on the InSight Diagnostic Display. Additionally, the system detects and alerts of leaks (visually and audibly) while closing solenoid valves of affected tanks to isolate the leak(s).

On the display, tanks are numbered starting with the tank at the top of the of the CNrG tailgate, "TANK-1", and ending with the tank lowest in the CNrG tailgate, in the system shown below, "TANK-7". When the system is operating without any issues, all boxes are green as shown below.



Figure 87. Main Display Screen

### Summary of Features

- Display screen inside the cab which gives live pressure monitoring for each tank and system.
- Visual warning in form of messages and color on the screen along with audible alarm whenever solenoid failure occurs.
- System visual and audible warning if one of the pressure transducers is unplugged in either ignition ON or OFF conditions.
- Whenever the ignition is OFF and truck is not running, system gives audible alarm in the event of any leaks on tank or system side. The operator needs to turn the ignition ON and check the display screen that will show the tank location of the leak.
- As a safety feature, all solenoids will be closed whenever there is a leak. A maintenance bypass code will need to be entered to be able to open solenoids and drive the vehicle. The leak detection feature is available only when the ignition is OFF.
- Leaks are detected at a pressure difference of 600 psi.

## HEIL CNrG SENTINEL SOLENOID SYSTEM OPTION (CONTINUED)

### Pressure Transducer Sensors

#### **WARNING**

ALL Pressure Transducer Sensors **MUST** be functioning for System to be able to detect a leak.

#### **WARNING**

Tank **MUST** be empty before removing tank Pressure Transducer Sensor.

Plugged directly into the live port of the valve of each tank and behind the FMM (Fuel Management Module) box live line, the pressure transducer sensors measure live pressures of each tank and of the system. When a pressure transducer sensor fails or becomes unplugged, the system sends a visual warning on the InSight Diagnostic Display along with an audible alarm.

Whenever there is a single sensor issue, the main screen will show which sensor has failed as shown in the figure to the top right. However, if there are multiple sensor issues, it will tell you to go to alarm summary screen to get more details as shown in the figure to the bottom right.

#### **NOTICE**

The audible buzzer will be active regardless of ignition ON or ignition OFF and will not turn OFF until the issue is corrected.

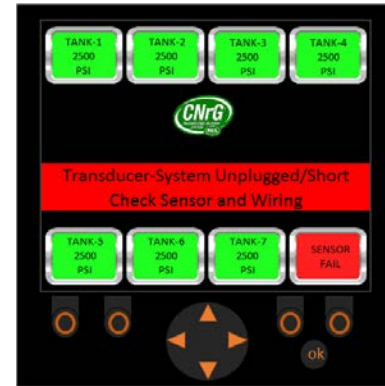

Figure 88. Pressure Transducer Sensor behind FMM

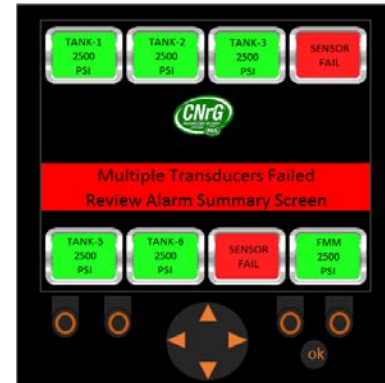

Figure 89. Multiple Pressure Transducer Sensors Unplugged/Faulty

# DURAPACK 5000

## HEIL CNrG SENTINEL SOLENOID SYSTEM OPTION (CONTINUED)

The Alarm Summary Screen can be reached by pressing the right arrow on the display twice.

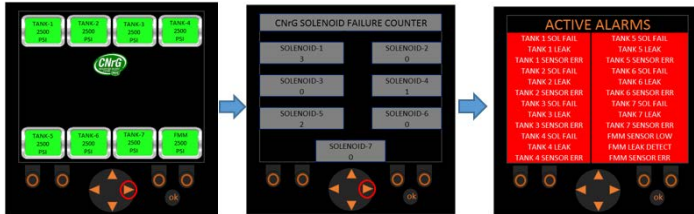

Figure 90. Path to Alarm Summary Screen



Figure 91. Alarm Summary Screen

### Solenoid System Function

The valve body on each CNG tank has an integrated solenoid. The solenoids are normally closed when the ignition is OFF and open when ignition is ON and a voltage is supplied to them.

### Leak Detection/Solenoid Lock

The system is capable of detecting a leak in the system or leak in any tank when the ignition is initially OFF and the leak starts. For safety purposes, if a leak is detected, all solenoids are locked in the closed position and not allowed to open until a maintenance code is entered and bypass is activated. The audible alarm activates whenever there is pressure difference detected of 600 psi or more and the truck ignition is OFF (ignition must be turned ON to see more details about the leak on the display screen).

### **NOTICE**

Authorized Service Personnel should contact Heil Technical Service for the maintenance code to unlock the CNG solenoids.

## HEIL CNrG SENTINEL SOLENOID SYSTEM OPTION (CONTINUED)

### Leak Detection/Solenoid Lock (Continued)

The figures on this page show example display screenshots of possible leak detection notifications. Other leak detection notifications exist and are not shown here.

### **WARNING**

You must follow all safety/emergency procedures of your company in the event of a CNG leak. At a minimum, follow the instructions on Emergency Shutdown Procedure <sup>176</sup> section of this manual.



**Figure 92. Tank 1 Leak.  
Maintenance Bypass Required.**



**Figure 93. Multiple Tank Leaks.  
Maintenance Bypass Required.**



**Figure 94. System Leak.  
Maintenance Bypass Required.**

## HEIL CNrG SENTINEL SOLENOID SYSTEM OPTION (CONTINUED)

### Solenoid Failure Detection

The system is capable of detecting solenoid failures to open (in the event of a wiring or component issue) when the ignition is turned ON as per requirement of NFPA 52.

Whenever there is a single solenoid issue, the main screen will show which solenoid has failed as seen on the figure to the top right of this page. However, if there are multiple solenoid issues, it will tell you to go to alarm summary screen to get more details as seen in the figure to the bottom right. **Alarm Summary Screen**<sup>[198]</sup> can be reached by pressing the right arrow on the display twice.

The figures on this page show example display screenshots of solenoid failure detection notifications. Other solenoid failure detection notifications exist and are not shown here.

To defuel after a solenoid failure on one of the tanks, first refer to **Heil CNrG Solenoid System Defueling After Solenoid Failure**<sup>[205]</sup> and then use one of the methods described in **CNG Fuel Module Defueling Methods**<sup>[181]</sup>.

### NOTICE

The audible buzzer will be active only when ignition is ON and will not turn OFF until the issue is corrected.



Figure 95. Display Screenshot: Tank 2 Solenoid Failure



Figure 96. Display Screenshot: Multiple Solenoids Failed

## HEIL CNrG SENTINEL SOLENOID SYSTEM OPTION (CONTINUED)

### Maintenance Bypass

The following are the steps must be followed by a qualified maintenance technician after getting any display messages described in this manual. This will allow a qualified service person to get the truck back on route/correct the issue:

### **WARNING**

Enabling Bypass Mode will disable System Leak Interlocks. Bypass will not open the solenoid of a leaking tank.

1. Driver will need to call maintenance department of their company in order to drive/move the truck since all solenoids are locked and need maintenance bypass for them to open.
2. For any leaking tank, open the oblong access covers on the street side of the CNrG tailgate and then close that tank's manual shut off valve. (You must correct the leaking tank before the system will allow the solenoid for that tank to open.) In case of system leak, solenoids will not open until Bypass Mode is "ON" (system leak is a leak detected in the line going from FMM to tanks on high pressure side).
3. Go inside the cab and on display screen hold "ok" button on screen until it prompts you to enter maintenance code.
4. Enter the maintenance bypass code and you will see the screen shown in the figure to the right.

### **NOTICE**

Authorized Service Personnel should contact Heil Technical Service for the maintenance bypass code to unlock the CNG solenoids.

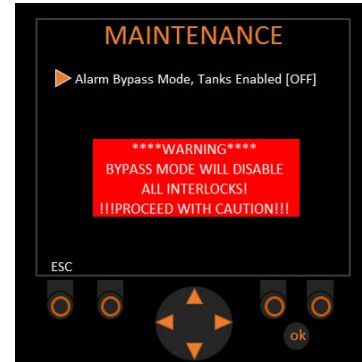

**Figure 97. Display  
Screenshot: Maintenance  
Screen**

5. Make sure you have first closed the manual shut off valves on the tanks that are leaking (Step 2). You will notice that the Bypass Mode is OFF by default. Press "ok" button and turn ON Bypass Mode. Once you do this, all solenoids (except leaking tank/tanks) open. However, all tanks are now connected to each other and to the main supply/return line. This is the reason it is very important to first perform Step 2 before performing this step.
6. You will now be able to drive the truck to your maintenance department to evaluate and repair the leak. The audible alarm will not go OFF until the issue is corrected.

# DURAPACK 5000

## HEIL CNrG SENTINEL SOLENOID SYSTEM OPTION (CONTINUED)

### Low Fuel Level Detection

The system is capable of detecting low fuel levels and will give audible and visual alerts that the truck needs to be refueled, as shown in the figure below. Whenever pressure drops below 500 psi on the system side, the system will show a Low Fuel Warning alert message along with an audible alert.

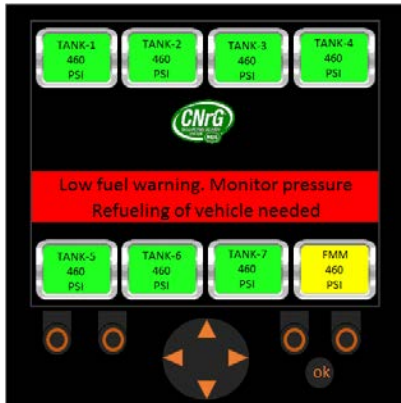

**Figure 98. Display Screenshot:  
Low Fuel Warning**

### CNG Tank Option Configuration

The system is designed for different tank configurations and is a common design which will work from 3 tank to 7 tank system. This helps the customer to upgrade to higher DGE (Diesel Gallon Equivalents) by adding more tanks without need to modify anything in this system. The figure below shows a snapshot of the Tank Option Configuration maintenance screen where you can configure the number of tanks on the truck.

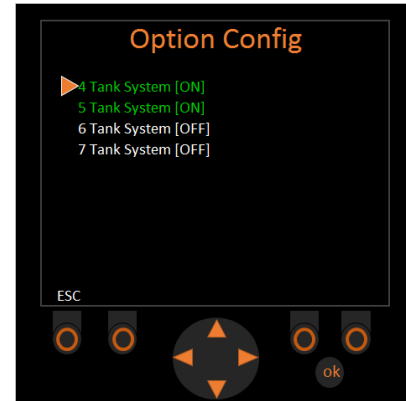
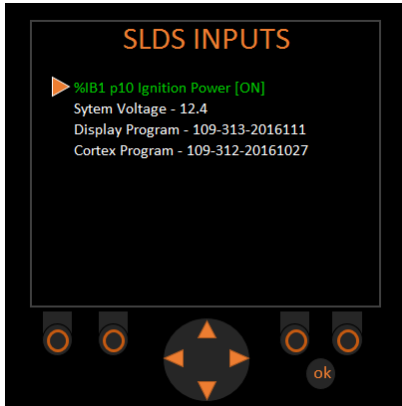

**Figure 99. Display Screenshot:  
Tank Option Configuration**

## HEIL CNrG SENTINEL SOLENOID SYSTEM OPTION (CONTINUED)

### System Inputs

The display screenshot shown below (within the maintenance mode menu) is used for troubleshooting and maintenance to gather information for the current status of the Ignition Power (ON or OFF) and the system voltage being supplied to the Controller. It also provides the software revisions of the Display and Controller programs.



**Figure 100. Display Screenshot: System Inputs**

### System Outputs

The display screenshot shown below (within the maintenance mode menu) is used for troubleshooting and maintenance to gather information for the current status of the Solenoids on each Tank (ON or OFF). It also provides the status of the System Alarm for the Controller.

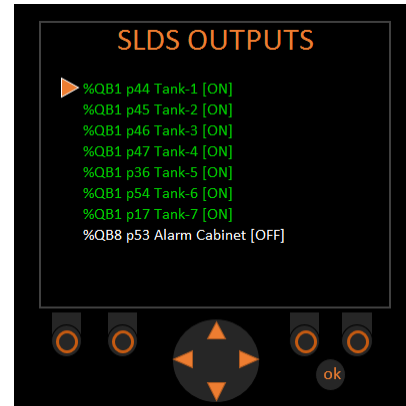

**Figure 101. Display Screenshot: System Outputs**

# DURAPACK 5000

## HEIL CNrG SENTINEL SOLENOID SYSTEM OPTION (CONTINUED)

### Ignition Power OFF

The display notification shown in the figure below will only be displayed in the event that the InSight Diagnostic Display has Ignition Power and the Controller does not have Ignition Power. This Alarm can be beneficial in the event that all Tank Solenoids Valves have failed to open due to the loss of Ignition Power, which is required to open the Tank Solenoids Valves.



**Figure 102. Display Screenshot: Ignition Power OFF**

### System Over Voltage

The display notification shown in the figure below will only be displayed in the event that the System Voltage is greater than 36 volts for 10 seconds, indicating that there is voltage too high to safely operate the Controller and Display.



**Figure 103. Display Screenshot: System Over Voltage**

# DURAPACK 5000

## HEIL CNrG SENTINEL SOLENOID SYSTEM OPTION (CONTINUED)

### System Under Voltage

The display notification shown in the figure below will only be displayed in the event that the System Voltage is less than 8 volts, indicating that there is voltage too low to safely operate the Controller and Display.

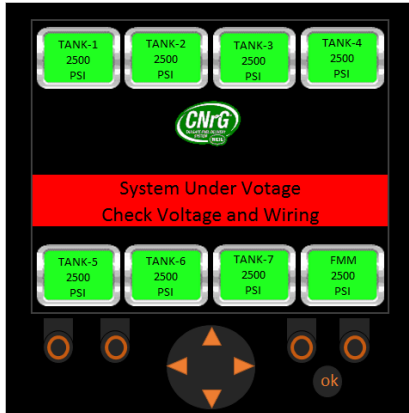

Figure 104. Display Screenshot: System Under Voltage

### Fuel Fill Mode

For the CNrG Solenoid System only, engage Fuel Fill Mode on the in-cab InSight Diagnostic Display to open the CNG solenoids, allowing for fast fill fueling. The "FUEL FILL MODE" button turns green when engaged. After Fuel Fill Mode is engaged, the Fuel Fill Mode remains active for one (1) hour or until the ignition key switch cycles ON-OFF-ON.

## **WARNING**

BEFORE fueling the CNrG Solenoid System (if equipped), **Fuel Fill Mode MUST** be engaged on the in-cab InSight Diagnostic Display. **While Fuel Fill Mode is engaged, the system will not detect leaks.**

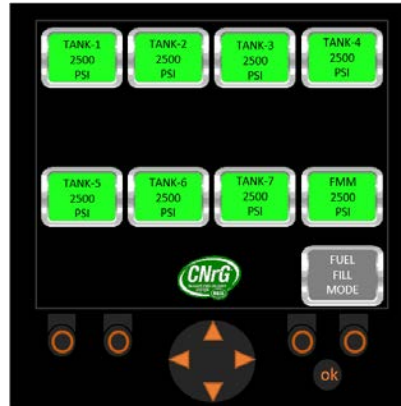

Figure 105. Display Screenshot: Fuel Fill Mode OFF



Figure 106. Display Screenshot: Fuel Fill Mode ON

# DURAPACK 5000

NOTES:

**A**

accident 24  
 achieving payloads 145  
 arm mechanism 17, 24, 85

**B**

battery disconnect switch 109, 115  
 before loading 119, 120  
 before operating the equipment 33  
 before starting a route 110  
 beware of overhead obstructions 33  
 bin 24  
 blade 24  
 blade control lever 77  
 body 17, 24  
 body preventive maintenance chart 160  
 buzzer switch 81

**C**

cab controls 17  
 callapsed position 24  
 care of decals 56  
 cart tipper 17, 24, 86  
 cart tipper control lever 86  
 caution 24, 31  
 check the hydraulic oil level 111  
 clean and inspect the hopper and packer panel 153  
 clean and inspect the tailgate 151

cold weather warmup procedure 110  
 comb lift and arm mechanism 17  
 compressed natural gas (CNG) option  
   CNG fuel cylinder and system inspection 190  
   CNG fuel system troubleshooting 191, 192, 193,  
   194, 195  
   CNG vehicle operator emergency response 176,  
   177  
 daily CNrG fuel system inspection 190  
 depressurizing procedure 184  
 emergency response for gas leaks 176  
 emergency shut down procedure 177  
 emergency venting/defueling procedure 177  
 fuel management module components 172, 173  
 fuel management module functions 172  
 fuel system shutdown procedure 176  
 fueling procedure 178, 179, 180, 181  
 high pressure filter change procedure 185  
 high pressure filter drain procedure 185  
 important safety information 168, 169, 170  
 inspection/preventive care schedule 189  
 lifting the vehicle 187  
 maintenance part numbers 183  
 maintenance 182, 189  
 preparation before maintenance 184, 189  
 pre-trip inspection 188  
 properties of natural gas 171  
 re-pressurizing procedure 184  
 signs of a fuel leak 171  
 starting vehicle 178

compressed natural gas (CNG) option  
  system components 172, 173, 174, 175  
  towing the vehicle 187  
  transfer fueling (defueling) 181  
  vehicle fire procedures 176  
  weekly system inspection 188  
  welding and hot work procedures 186

contact information  
  Customer Care 11  
  Parts Central 11  
  Technical Service 11

controls 67

cycle all hydraulic functions 111, 113

## D

daily checklist 94, 97, 109

danger 24, 31

decal images 43, 44, 45, 46, 47, 48, 49, 51, 52, 53

decal placement 37, 38, 39, 40, 41

driving to pick-up locations 119

## E

ejector & tailgate controls 17

ejector lever 80

ejector panel 113

ejector panel & cylinders 17

end of day procedures 157

extend/EXTEND 24

## F

factory body props 91

final inspection 157

front head 17, 24

FULLY RETRACTED POSITION 24

## G

glossary 24

grab handles 17

## H

hand holds (grab handles) 24

harm 24

hazard 24

Heil CNrG optional solenoid system  
  Heil CNrG solenoid system option 196  
  maintenance bypass 201  
  pressure transducer sensors 197  
  solenoid failure detection 200  
  system over voltage 204

Heil CNrG SENTINEL solenoid system option  
  defueling after solenoid failure 205  
  leak detection 199  
  leak detection/solenoid lock 198  
  low fuel level detection 202  
  solenoid failure detection 198  
  solenoid system function 198  
  system inputs 203

Heil CNrG SENTINEL solenoid system option  
 system outputs 203  
 system under voltage 205  
 tank option configuration 202  
 hopper 17, 24  
 hopper light switch 82  
 hopper sill 17  
 how to use this manual 5  
 hydraulic oil tank 17, 112  
 hydraulic pump 17

**I**

ignition keys 157  
 illuminate 24  
 important safety precautions 32  
 IN 24  
 in-cab display 67  
 counter screen 74  
 diagnostic, maintenance, and option configuration  
 screens 75  
 display indicators 70, 71  
 function buttons 69  
 home screen 68  
 message banner 72, 73  
 status LED 71  
 incident 24  
 informational decals 36  
 in-transit position 114

**L**

latch bar 17, 24  
 latch bar assembly 87  
 LATCHED 24  
 leaving the route for the landfill/transfer station 146  
 LOAD POSITION 24  
 loading refuse manually 120  
 loading refuse with a cart tipper 140, 141, 142, 143  
 loading refuse with a reeving mechanism 123, 124,  
 125, 126, 127  
 loading refuse with a roll bar mechanism 136, 137, 139  
 loading refuse with a winch 128, 129, 130, 131  
 loading refuse with an arm mechanism 132, 133, 134,  
 135  
 locking out the unit 61  
 locking the tailgate 153  
 Lock-Out/Tag-Out 59  
 Lock-Out/Tag-Out procedure 61  
 lower/LOWER 24  
 lowering the tailgate 152  
 lubrication guide 164, 165

**M**

may 24  
 must 24

**N**

notice 24, 31

## O

off/OFF 24  
on/ON 24  
operator 24  
optional container lift controls 83  
optional outside controls 83, 84, 85, 86, 87  
overhead clearances 33  
overview of landfill/transfer station/recycle center procedures 149

## P

PACK POSITION 24  
packer blade 17, 24  
packer blade lever 76  
packer panel 17, 24  
packing on-the-move 145  
packing refuse into the body 122  
parking the unit 157  
precautionary statements 31  
preparing the unit to check the hydraulic oil level 111  
preparing to return to route 153  
pressure washer precautions 56  
product nomenclature 15, 16, 17  
propping the tailgate 91, 92  
PTO 24

## R

raise/RAISE 24

raising the tailgate 150  
recommended hydraulic oil 111  
reeving mechanism 17, 24, 84  
reflective safety materials 55  
REL 24  
remove refuse from the engine and exhaust areas 153  
reports to employer/supervisor 157  
retract/RETRACT 24  
riding step 17, 24  
roll bar 17, 85  
roll bar assembly 24  
RPM 24

## S

safety decals 36  
serial plate 14  
serial plate locations 13  
setting up the unit for dumping 149  
should 24  
side access door 17, 24  
sight gauge 112  
slide (upper panel) assembly 17  
slide/blade controls 17  
standard outside controls 76, 77, 78, 79, 80, 81, 82  
streetside vs. curbside 13  
sump doors and washout system 153

## T

tailgate 17

tailgate access covers 24  
tailgate cylinders 17  
tailgate left and right access covers 17  
tailgate lever 80  
tailgate props 17  
tailgate raise cycle 113  
throttle advance 17, 24  
throttle advance switch 81, 82  
to the mechanic 9  
to the operator 7, 8  
to the owner 6  
traveling position 114

warranty claims and inquiries 10  
washout system 157  
when working in or around the vehicle 33  
winch 24, 84  
winch assembly 17

## U

unit 24  
UNLATCHED 24  
unloading 33  
unloading refuse 149, 150, 151, 152, 153  
unlocking and raising the tailgate 149  
upper panel 24  
upper panel control lever 78, 79  
upper panel lever 76  
use of curb side drive 119  
use personal protective equipment 33  
using a latch bar 143, 144

## W

warming up the hydraulic oil 110  
warning 24, 31

# DURAPACK 5000

NOTES:



## HEIL ENVIRONMENTAL WARRANTY STATEMENT

Our products are subject to a limited warranty as outlined in the document linked below – please see the linked Heil Warranty Policies & Procedures for our full, limited warranty.

As a summary, The Heil Co. d/b/a Heil Environmental (“Heil”) warrants its solid waste collection equipment to be free from defects in material and workmanship under normal use for a period of one (1) year or 2000 hours of operation (whichever comes first) from the date of equipment In-Service or during the period of coverage offered by an extended warranty program (if one is offered on a particular product), when proper service and maintenance as described in Heil Service Bulletins and Parts & Service Manuals are performed. The standard or extended equipment warranty is not transferable except for sales demonstration units. Heil only warrants the collection body. Please consult respective chassis manufacturer for respective specifics on chassis.

Ask your local Heil Dealer about our Extended Warranty offerings or contact Heil Customer Care at 866-ASK-HEIL (866.275.4345). For Warranty programs for international accounts outside of North America please consult with your Regional Manager for further details and/or appropriate policies.

EXCEPT AS CONTAINED IN THE HEIL WARRANTY POLICIES AND PROCEDURES, HEIL MAKES NO OTHER WARRANTY, EXPRESSED OR IMPLIED, AND MAKES NO WARRANTY OF MERCHANTABILITY OR OF FITNESS FOR ANY PARTICULAR PURPOSE. HEIL DOES NOT ASSUME ANY LIABILITY FOR LOSS OF PROFITS, PRODUCT, TIME, OR ANY OTHER DIRECT, INCIDENTAL, OR INDIRECT CONSEQUENTIAL LOSSES, DAMAGES OR DELAYS. ANY IMPROPER USE, OPERATION BEYOND RATED EQUIPMENT/ COMPONENT CAPACITY, SUBSTITUTION OF PARTS THAT ARE NOT HEIL APPROVED, OR ANY ALTERATION OR REPAIR BY OTHERS IN SUCH A MANNER AS IN HEIL’S SOLE JUDGMENT AFFECTS THE PRODUCT OPERATION OR INTEGRITY SHALL VOID THE WARRANTY.

Heil retains the right to modify its factory warranty program at any time. The warranty in place at the time of your respective purchase applies.

Please see the full limited warranty as outlined at <https://www.heil.com/warranty/> under Heil Warranty Policies and Procedures.



[www.heil.com](http://www.heil.com)

Customer Care:  
866-ASK-HEIL  
(866-275-4345)

The Heil Co.  
4301 Gault Avenue North  
Fort Payne, AL 35967-9984

Parts Central:  
800-528-5308

Technical Service:  
866-310-4345  
[TechSupport@DoverESG.com](mailto:TechSupport@DoverESG.com)